



Agilent 1200 Series Quaternary Pump



User Manual



Agilent Technologies

Notices

© Agilent Technologies, Inc. 2006-2007, 2008

No part of this manual may be reproduced in any form or by any means (including electronic storage and retrieval or translation into a foreign language) without prior agreement and written consent from Agilent Technologies, Inc. as governed by United States and international copyright laws.

Manual Part Number

G1311-90011

Edition

11/08

Printed in Germany

Agilent Technologies
Hewlett-Packard-Strasse 8
76337 Waldbronn

Research Use Only

Not for use in Diagnostic Procedures.

Warranty

The material contained in this document is provided “as is,” and is subject to being changed, without notice, in future editions. Further, to the maximum extent permitted by applicable law, Agilent disclaims all warranties, either express or implied, with regard to this manual and any information contained herein, including but not limited to the implied warranties of merchantability and fitness for a particular purpose. Agilent shall not be liable for errors or for incidental or consequential damages in connection with the furnishing, use, or performance of this document or of any information contained herein. Should Agilent and the user have a separate written agreement with warranty terms covering the material in this document that conflict with these terms, the warranty terms in the separate agreement shall control.

Technology Licenses

The hardware and/or software described in this document are furnished under a license and may be used or copied only in accordance with the terms of such license.

Restricted Rights Legend

If software is for use in the performance of a U.S. Government prime contract or subcontract, Software is delivered and licensed as “Commercial computer software” as defined in DFAR 252.227-7014 (June 1995), or as a “commercial item” as defined in FAR 2.101(a) or as “Restricted computer software” as defined in FAR 52.227-19 (June 1987) or any equivalent agency regulation or contract clause. Use, duplication or disclosure of Software is subject to Agilent Technologies’ standard commercial license terms, and non-DOD Departments and Agencies of the U.S. Government will

receive no greater than Restricted Rights as defined in FAR 52.227-19(c)(1-2) (June 1987). U.S. Government users will receive no greater than Limited Rights as defined in FAR 52.227-14 (June 1987) or DFAR 252.227-7015 (b)(2) (November 1995), as applicable in any technical data.

Safety Notices

CAUTION

A **CAUTION** notice denotes a hazard. It calls attention to an operating procedure, practice, or the like that, if not correctly performed or adhered to, could result in damage to the product or loss of important data. Do not proceed beyond a **CAUTION** notice until the indicated conditions are fully understood and met.

WARNING

A **WARNING** notice denotes a hazard. It calls attention to an operating procedure, practice, or the like that, if not correctly performed or adhered to, could result in personal injury or death. Do not proceed beyond a **WARNING** notice until the indicated conditions are fully understood and met.

Contents

1	Introduction	7
	Introduction to the Quaternary Pump	8
	Overview of the Hydraulic Path	9
	Instrument Layout	16
	The Electronics	17
	Electrical Connections	18
	Agilent 1200 Series Interfaces	20
2	Site Requirements and Specifications	21
	Site Requirements	22
	Physical Specifications	25
	Performance Specifications	26
3	Installing the Pump	29
	Unpacking the Quaternary Pump	30
	Optimizing the Stack Configuration	33
	Installing the Quaternary Pump	36
	Connecting Modules and Control Software	39
	Flow Connections of the Quaternary Pump	41
	Priming and Purging the System	44
4	Using the Quaternary Pump	49
	Hints for Successful Use of the Quaternary Pump	50
	Solvent Information	51
	Prevent Blocking of Solvent Filters	52
	Algae Growth in HPLC Systems	53
5	Optimizing Performance	55
	Operational Hints for the Vacuum Degasser	56
	Operational Hints for the Multi Channel Gradient Valve (MCGV)	57
	When to use the Seal Wash Option	58
	When to Use Alternative Seals	59

Optimize the Compressibility Compensation Setting	60
6 Troubleshooting and Test Functions	63
Agilent Lab Advisor Software	64
Overview of the Pump's Indicators and Test Functions	65
Status Indicators	66
User Interfaces	68
7 Maintenance	69
Introduction to Repairing the Pump	70
Early Maintenance Feedback (EMF)	73
Overview of Repairing the Pump	75
Simple Repairs	77
8 Parts and Materials for Maintenance	105
Overview of Main Assemblies	106
Pump Head Assembly	110
Pump Head Assembly with Seal Wash Option	112
Outlet Ball Valve Assembly	114
Purge Valve Assembly	115
Active Inlet Valve Assembly	116
Accessory Kit G1311-68705	117
Seal Wash Option Kit G1311-68711	118
9 Identifying Cables	119
Cable Overview	120
Analog Cables	122
Remote Cables	125
BCD Cables	130
External Contact Cable	132
CAN/LAN Cables	133
Auxiliary Cable	134
RS-232 Cables	135
10 Appendix	137
General Safety Information	138

The Waste Electrical and Electronic Equipment (WEEE) Directive
(2002/96/EC) 141

Lithium Batteries Information 142

Radio Interference 143

Sound Emission 144

Agilent Technologies on Internet 145

Contents

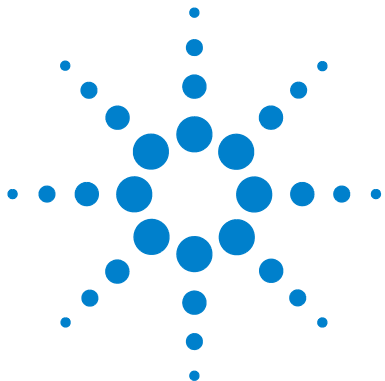

1 Introduction

Introduction to the Quarternary Pump	8
Overview of the Hydraulic Path	9
How Does the Pump Work?	11
How Does Compressibility Compensation Work?	14
How Does Variable Stroke Volume Work?	14
Early Maintenance Feedback (EMF)	15
Instrument Layout	16
The Electronics	17
Electrical Connections	18
Agilent 1200 Series Interfaces	20



Introduction to the Quaternary Pump

The quaternary pump comprises a solvent cabinet, a vacuum degasser and a four-channel gradient pump. The four-channel gradient pump comprises a high-speed proportioning valve and a pump assembly. It provides gradient generation by low pressure mixing. Degassing is a must for a low-pressure gradient system therefore the Agilent 1200 Series vacuum degasser is part of the quaternary pump system. A solvent cabinet provides enough space for four one-liter bottles. An active seal wash (optional) is available when the quaternary pump is used with concentrated buffer solutions.

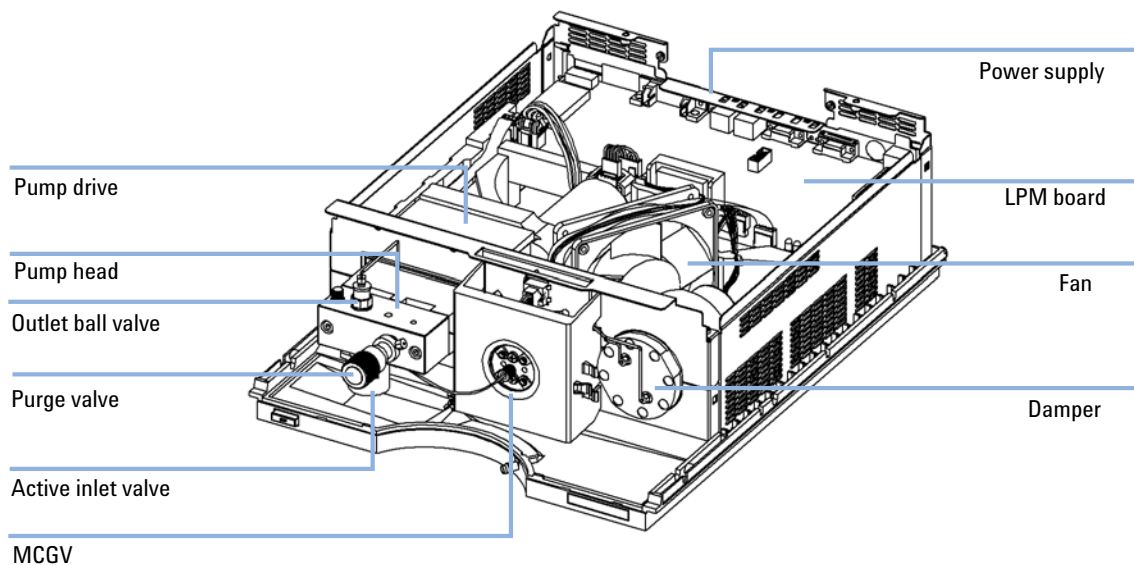

Figure 1 Overview of the Quaternary Pump

Overview of the Hydraulic Path

The quaternary pump is based on a two-channel, dual plunger in-series design which comprises all essential functions that a solvent delivery system has to fulfill. Metering of solvent and delivery to the high-pressure side are performed by one pump assembly which can generate pressure up to 400 bar.

Degassing of the solvents is done in a vacuum degasser and solvent compositions are generated on the low-pressure side by a high-speed proportioning valve.

The pump assembly includes a pump head with an active inlet valve which has an replaceable cartridge, and an outlet valve. A damping unit is connected between the two plunger chambers. A purge valve including a PTFE frit is fitted at the pump outlet for convenient priming of the pump head.

An active seal wash (optional) is available when the quaternary pump is used with concentrated buffer solutions.

1 Introduction
Overview of the Hydraulic Path

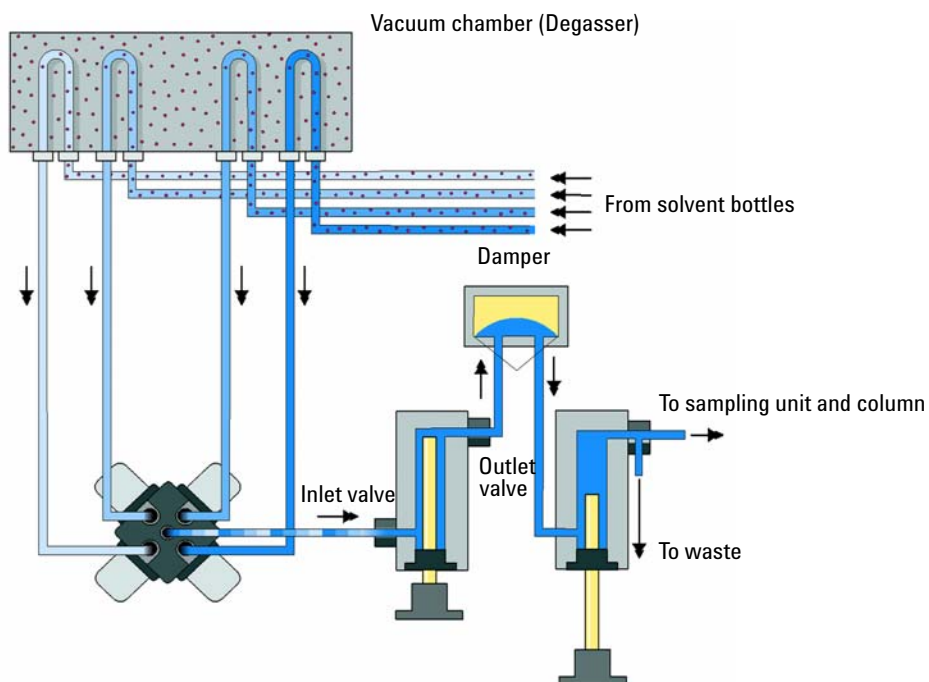

Figure 2 Hydraulic Path of the Quaternary Pump

How Does the Pump Work?

The liquid runs from the solvent reservoir through the degasser to the MCGV and from there to the active inlet valve. The pump assembly comprises two substantially identical plunger/chamber units. Both plunger/chamber units comprise a ball-screw drive and a pump head with one sapphire plunger for reciprocating movement in it.

A servo-controlled variable reluctance motor drives the two ball-screw drives in opposite directions. The gears for the ball-screw drives have different circumferences (ratio 2:1) allowing the first plunger to move at twice the speed of the second plunger. The solvent enters the pump head close to the bottom limit and leaves it at its top. The outer diameter of the plunger is smaller than the inner diameter of the pump head chamber allowing the solvent to fill the gap in between. The first plunger has a stroke volume in the range of 20–100 μl depending on the flow rate. The microprocessor controls all flow rates in a range of 1 μl –10 ml/min. The inlet of the first plunger/chamber unit is connected to the active inlet valve which is processor-controlled opened or closed allowing solvent to be drawn into the first plunger pump unit. variable reluctance motor drives the two ball-screw drives in opposite directions. The gears for the ball-screw drives have different circumferences (ratio 2:1) allowing the first plunger to move at twice the speed of the second plunger. The solvent enters the pump head close to the bottom limit and leaves it at its top. The outer diameter of the plunger is smaller than the inner diameter of the pump head chamber allowing the solvent to fill the gap in between.

The outlet of the first plunger/chamber unit is connected through the outlet ball valve and the damping unit to the inlet of the second plunger/chamber unit. The outlet of the purge valve assembly is then connected to the following chromatographic system.

1 Introduction

Overview of the Hydraulic Path

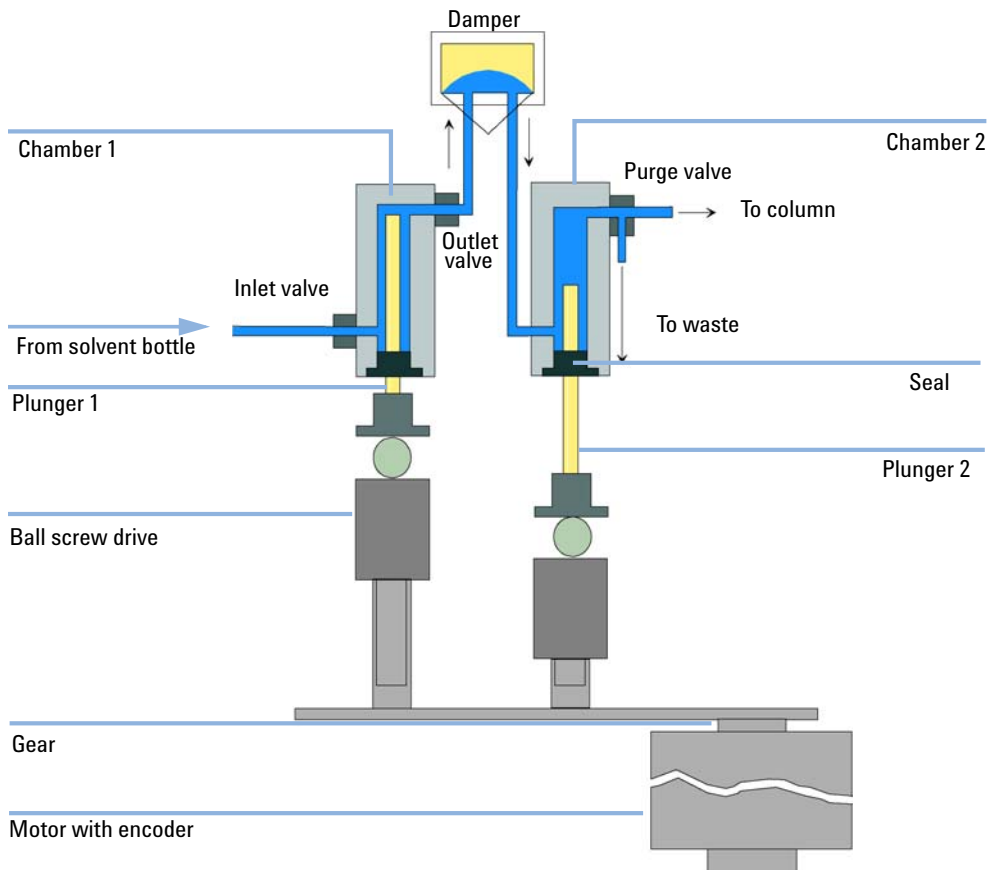

Figure 3 Principle of the Pump

When turned on, the quaternary pump runs through an initialization procedure to determine the upper dead center of the first plunger. The first plunger moves slowly upwards into the mechanical stop of chamber and from there it moves back a predetermined path length. The controller stores this plunger position in memory. After this initialization the quaternary pump starts operation with the set parameters. The active inlet valve is opened and the down-moving plunger draws solvent into the first chamber. At the same time the second plunger is moving upwards delivering into the system. After a controller-defined stroke length (depending on the flow rate) the drive motor is stopped and the active inlet valve is closed. The motor direction is reversed and moves the first plunger up until it reaches the stored upper limit and at

the same time moving the second plunger downwards. Then the sequence starts again moving the plungers up and down between the two limits. During the up movement of the first plunger the solvent in the chamber is pressed through the outlet ball valve into the second chamber. The second plunger draws in half of the volume displaced by the first plunger and the remaining half volume is directly delivered into the system. During the drawing stroke of the first plunger, the second plunger delivers the drawn volume into the system.

For solvent compositions from the solvent bottles A, B, C, D the controller divides the length of the intake stroke in certain fractions in which the gradient valve connects the specified solvent channel to the pump input.

Table 1 Pump Details

Delay volume	800–1100 µl, dependent on back pressure
Materials in contact with mobile phase	
DCGV	PTFE
Pump head	SST, gold, sapphire, ceramic
inlet valve	SST, gold, sapphire, ruby, ceramic, PTFE
Outlet valve	SST, gold, sapphire, ruby
Adapter	SST, gold
Purge valve	SST, gold, PTFE, ceramic, PEEK
Damping unit	Gold, SST

For quaternary pump specifications, see [“Site Requirements and Specifications”](#) on page 21.

How Does Compressibility Compensation Work?

The compressibility of the solvents in use will affect retention-time stability when the back pressure in the system changes (for example, ageing of column). In order to minimize this effect, the pump provides a compressibility compensation feature which optimizes the flow stability according to the solvent type. The compressibility compensation is set to a default value and can be changed through the user interface.

Without a compressibility compensation the following will happen during a stroke of the first plunger. The pressure in the plunger chamber increases and the volume in the chamber will be compressed depending on backpressure and solvent type. The volume displaced into the system will be reduced by the compressed volume.

With a compressibility value set the processor calculates a compensation volume, that is depending on the backpressure in the system and the selected compressibility. This compensation volume will be added to the normal stroke volume and compensates the previous described *loss* of volume during the delivery stroke of the first plunger.

How Does Variable Stroke Volume Work?

Due to the compression of the pump-chamber volume each plunger stroke of the pump will generate a small pressure pulsation, influencing the flow ripple of the pump. The amplitude of the pressure pulsation is mainly dependent on the stroke volume and the compressibility compensation for the solvent in use. Small stroke volumes will generate pressure pulsations of smaller amplitude than higher stroke volumes at same flow rates. In addition the frequency of the pressure pulsations will be higher. This will decrease the influence of flow pulsations on quantitative results.

In gradient mode smaller stroke volumes resulting in less flow ripple will improve composition ripple.

The module uses a processor-controlled spindle system to drive its plungers. The normal stroke volume is optimized for the selected flow rate. Small flow rates use a small stroke volume while higher flow rates use a higher stroke volume.

The stroke volume for the pump is set to AUTO mode. This means that the stroke is optimized for the flow rate in use. A change to larger stroke volumes is possible but not recommended.

Early Maintenance Feedback (EMF)

The early maintenance feedback (EMF) feature monitors the usage of specific components in the instrument, and provides feedback when the user-settable limits have been exceeded. The visual feedback in the user interface provides an indication that maintenance procedures should be scheduled.

For details on EMF counters and how to use them, see Agilent Lab Advisor.

Instrument Layout

The industrial design of the module incorporates several innovative features. It uses Agilent's E-PAC concept for the packaging of electronics and mechanical assemblies. This concept is based upon the use of expanded polypropylene (EPP) layers foam plastic spacers in which the mechanical and electronic boards components of the module are placed. This pack is then housed in a metal inner cabinet which is enclosed by a plastic external cabinet. The advantages of this packaging technology are:

- virtual elimination of fixing screws, bolts or ties, reducing the number of components and increasing the speed of assembly/disassembly,
- the plastic layers have air channels molded into them so that cooling air can be guided exactly to the required locations,
- the plastic layers help cushion the electronic and mechanical parts from physical shock, and
- the metal inner cabinet shields the internal electronics from electromagnetic interference and also helps to reduce or eliminate radio frequency emissions from the instrument itself.

The Electronics

The electronics are comprised of four main components:

- The low pressure pump main board (LPM).
- Power supply.

Optional:

- Interface board (BCD/external contacts).
- LAN Communication Card.

Low-Pressure Pump Main Board (LPM)

The board controls all information and activities of all assemblies within the module. The operator enters parameters, changes modes and controls the module through interfaces (CAN, GPIB or RS-232C) connected to the user-interfaces.

The Main Power Supply Assembly

The main power supply comprises a closed assembly (no component-level repair possibility). The power supply provides all DC voltages used in the module. The line voltage can vary in a range from 100 – 120 or 220 – 240 volts AC \pm 10 % and needs no manual setting.

Optional Interface Boards

The Agilent 1200 Series modules have one optional board slot that allows to add an interface board to the modules. Optional interface boards for the Agilent 1200 Series are:

- BCD Board
- LAN Communication Card

Electrical Connections

- The GPIB connector is used to connect the pump with a computer. The address and control switch module next to the GPIB connector determines the GPIB address of your pump. The switches are preset to a default address (“[Agilent 1200 Series Interfaces](#)” on page 20). This address is recognized at powercycling the module.
- The CAN bus is a serial bus with high speed data transfer. The two connectors for the CAN bus are used for internal Agilent 1200 Series module data transfer and synchronization.
- One analog output provides a pressure signal for integrators or data handling systems.
- The interface board slot is used for external contacts and BCD bottle number output or LAN connections.
- The REMOTE connector may be used in combination with other analytical instruments from Agilent Technologies if you want to use features such as start, stop, common shut down, prepare, and so on.
- With the appropriate software, the RS-232C connector may be used to control the module from a computer through a RS-232C connection. See your software documentation for further information.
- The power input socket accepts a line voltage of 100–120 or 220–240 volts AC \pm 10% with a line frequency of 50 or 60 Hz. Maximum power consumption is 220 VA. There is no voltage selector on your module because the power supply has wide-ranging capability. There are no externally accessible fuses, because automatic electronic fuses are implemented in the power supply. The security lever at the power input socket prevents the module cover from being taken off when line power is still connected.

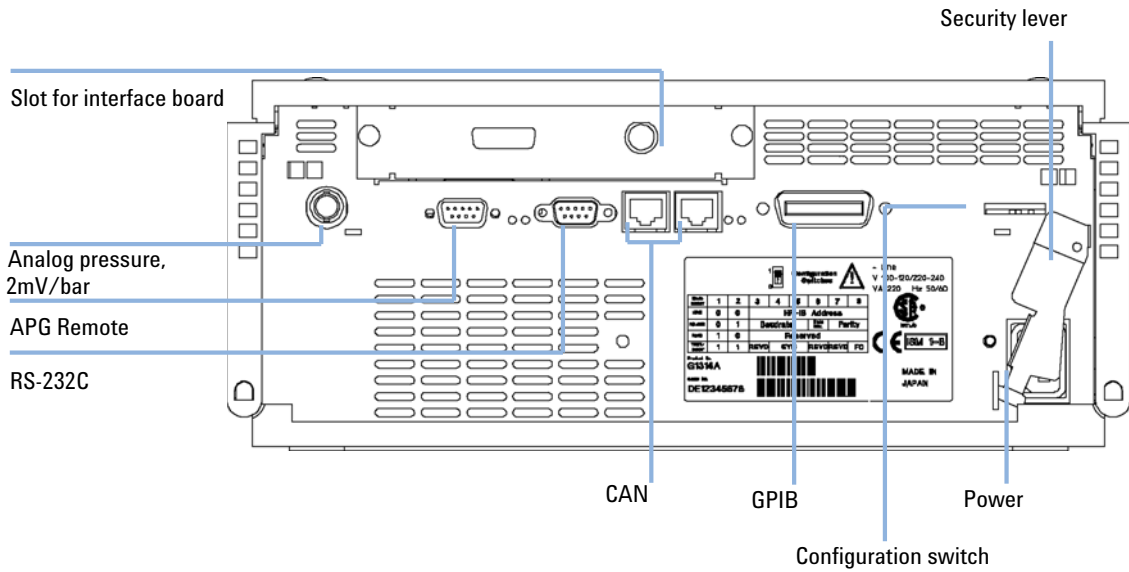

Figure 4 Rear View of Pump - Electrical Connections and Label

Agilent 1200 Series Interfaces

The Agilent 1200 Series modules provide the following interfaces:

Table 2 Agilent 1200 Series Interfaces

Interface Type	Pumps	Autosampler	DA Detector MW Detector FL Detector	VW Detector RI Detector	Thermostatted Column Compartment	Vacuum Degasser
CAN	Yes	Yes	Yes	Yes	Yes	No
GPIB	Yes	Yes	Yes	Yes	Yes	No
RS-232C	Yes	Yes	Yes	Yes	Yes	No
APG Remote	Yes	Yes	Yes	Yes	Yes	Yes
Analog	Yes	No	2 ×	1 ×	No	Yes ¹
Interface board ²	Yes	Yes	Yes	Yes	No	No

¹ The vacuum degasser will have a special connector for specific use. For details, see the degasser manual.

² The interface board slot (not common to all modules) provides specific interfacing needs (external contacts, BCD, LAN and so on).

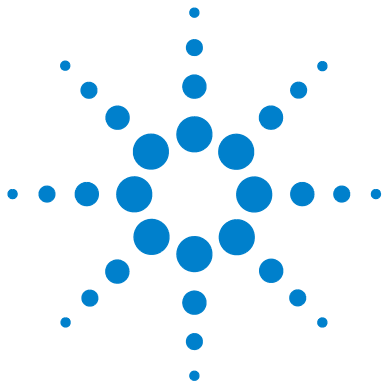

2 Site Requirements and Specifications

Site Requirements	22
Power Consideration	22
Power Cords	23
Bench Space	24
Environment	24
Physical Specifications	25
Performance Specifications	26



Site Requirements

A suitable environment is important to ensure optimum performance of the instrument.

Power Consideration

The module power supply has wideranging capability (see [Table 3](#) on page 25). It accepts any line voltage in the range described in the above mentioned table. Consequently there is no voltage selector in the rear of the module. There are also no externally accessible fuses, because automatic electronic fuses are implemented in the power supply.

WARNING

Incorrect line voltage at the instrument

Shock hazard or damage of your instrumentation can result, if the devices are connected to a line voltage higher than specified.

→ Connect your instrument to the specified line voltage.

WARNING

Module is partially energized when switched off, as long as the power cord is plugged in.

Repair work at the module can lead to personal injuries, e.g. shock hazard, when the cover is opened and the module is connected to power.

→ Remove the power cable from the instrument before opening the cover.

→ Do not connect the power cable to the Instrument while the covers are removed.

CAUTION

Unaccessible power plug.

In case of emergency it must be possible to disconnect the instrument from the power line at any time.

- Make sure the power connector of the instrument can be easily reached and unplugged.
 - Provide sufficient space behind the power socket of the instrument to unplug the cable.
-

Power Cords

Different power cords are offered as options with the module. The female end of all power cords is identical. It plugs into the power-input socket at the rear of the module. The male end of each power cord is different and designed to match the wall socket of a particular country or region.

WARNING

The absence of ground connection and the use of an unspecified power cord can lead to electric shock or short circuit.

Electric Shock

- Never operate your instrumentation from a power outlet that has no ground connection.
 - Never use a power cord other than the Agilent Technologies power cord designed for your region.
-

WARNING

Use of unsupplied cables

Using cables not supplied by Agilent Technologies can lead to damage of the electronic components or personal injury.

- Never use cables other than the ones supplied by Agilent Technologies to ensure proper functionality and compliance with safety or EMC regulations.
-

Bench Space

The module dimensions and weight (see [Table 3](#) on page 25) allow to place the module on almost any laboratory bench. It needs an additional 2.5 cm (1.0 inches) of space on either side and approximately 8 cm (3.1 inches) in the rear for the circulation of air and electric connections.

If the bench should carry a complete Agilent 1200 Series system, make sure that the bench is designed to carry the weight of all the modules.

NOTE

The module should be operated in a horizontal position!

Environment

Your module will work within specifications at ambient temperatures and relative humidity as described in [Table 3](#) on page 25.

CAUTION

Condensation within the module

Condensation will damage the system electronics.

- Do not store, ship or use your module under conditions where temperature fluctuations could cause condensation within the module.
 - If your module was shipped in cold weather, leave it in its box and allow it to warm slowly to room temperature to avoid condensation.
-

Physical Specifications

Table 3 Physical Specifications

Type	Specification	Comments
Weight	11 kg (25 lbs)	
Dimensions (width × depth × height)	140 x 345 x 435 mm (5.5 x 13.5 x 17 inches)	
Line voltage	100 – 240 VAC, ± 10%	Wide-ranging capability
Line frequency	50 or 60 Hz, ± 5%	
Power consumption	180 VA, 55 W / 188 BTU	Maximum
Ambient operating temperature	4–55 °C (41–131 °F)	
Ambient non-operating temperature	40–70 °C (-4–158 °F)	
Humidity	< 95%, at 25–40 °C (77–104 °F)	Non-condensing
Operating Altitude	Up to 2000 m (6500 ft)	
Non-operating altitude	Up to 4600 m (14950 ft)	For storing the module
Safety standards: IEC, CSA, UL	Installation Category II, Pollution Degree 2	For indoor use only. Research Use Only. Not for use in Diagnostic Procedures.

Performance Specifications

Table 4 Performance Specification Agilent 1200 Series Quaternary Pump

Type	Specification
Hydraulic system	Dual plunger in series pump with proprietary servo-controlled variable stroke drive, floating plungers and active inlet valve
Setable flow range	0.001 – 10 ml/min, in 0.001 ml/min increments
Flow range	0.2 – 10.0 ml/min
Flow precision	± 0.07% RSD, or ± 0.02 min SD whatever is greater, based on retention time at constant room temperature
Flow accuracy	± 1% or 10 µl/min whatever is greater
Pressure	Operating range 0 – 40 MPa (0 – 400 bar, 0 – 5880 psi) up to 5 ml/min Operating range 0 – 20 MPa (0 – 200 bar, 0 – 2950 psi) up to 10 ml/min
Pressure pulsation	< 2 % amplitude (typically < 1 %), at 1 ml/min isopropanol, at all pressures > 1 MPa (10 bar)
Compressibility compensation	User-selectable, based on mobile phase compressibility
Recommended pH range	1.0 – 12.5, solvents with pH < 2.3 should not contain acids which attack stainless steel
Gradient formation	Low pressure quaternary mixing/gradient capability using proprietary high-speed proportioning valve Delay volume 800 – 1100 µl, dependent on back pressure
Composition Range	0 – 95 % or 5 – 100 %, user selectable
Composition Precision	< 0.2 % RSD, at 0.2 and 1 ml/min
Control and data evaluation	Agilent control software (e.g. ChemStation, EZChrom, OL, etc.)
Communications	Controller-area network (CAN), GPIB, RS-232C, APG Remote: ready, start, stop and shut-down signals, LAN optional

Table 4 Performance Specification Agilent 1200 Series Quaternary Pump

Safety and maintenance	Extensive diagnostics, error detection and display (through control module and Agilent Lab Monitor & Diagnostic Software), leak detection, safe leak handling, leak output signal for shutdown of pumping system. Low voltages in major maintenance areas.
GLP features	Early maintenance feedback (EMF) for continuous tracking of instrument usage in terms of seal wear and volume of pumped mobile phase with user-settable limits and feedback messages. Electronic records of maintenance and errors.
Housing	All materials recyclable.

2 Site Requirements and Specifications

Performance Specifications

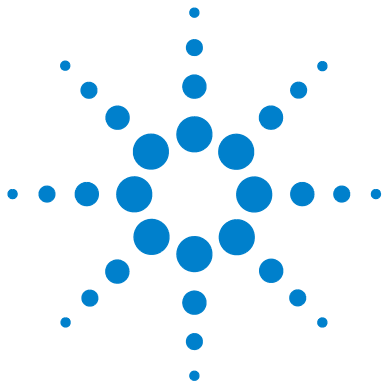

3 Installing the Pump

Unpacking the Quaternary Pump	30
Damaged Packaging	30
Delivery Checklist	30
Accessory Kit Contents G1311-68705	31
Accessory Kit Contents—Vacuum Degasser	32
Optimizing the Stack Configuration	33
Installing the Quaternary Pump	36
Connecting Modules and Control Software	39
Connecting Agilent 1200 Series modules	39
Connecting an Agilent 1200 Series Vacuum Degasser	40
Connecting control software and/or control modules	40
Flow Connections of the Quaternary Pump	41
Priming and Purging the System	44
Priming with a Syringe	45
Priming with the Pump	47



Unpacking the Quaternary Pump

Damaged Packaging

Upon receipt of your module, inspect the shipping containers for any signs of damage. If the containers or cushioning material are damaged, save them until the contents have been checked for completeness and the instrument has been mechanically and electrically checked. If the shipping container or cushioning material is damaged, notify the carrier and save the shipping material for the carrier's inspection.

Delivery Checklist

Ensure all parts and materials have been delivered with the quaternary pump. The delivery checklist is shown in [Table 5](#) on page 30. To aid in parts identification, please see [“Parts and Materials for Maintenance”](#) on page 105. Please report missing or damaged parts to your local Agilent Technologies sales and service office.

Table 5 Quaternary Pump Checklist (continued)

Description	Quantity
Quaternary pump	1
Solvent cabinet	1 (5065-9981)
Solvent bottles	4 (3 transparent 9301-1420, 1 amber 9301-1450)
Bottle head assembly	4 (G1311-60003)
Waste tube, purge valve	1 (5062-2461, reorder number, 5 m)
Vacuum degasser	1
Solvent tubes for the degasser	4 (G1322-67300)
cablesPower	2
CAN cable	1

Table 5 Quaternary Pump Checklist (continued)

Description	Quantity
Remote cable	As ordered
Signal cable	As ordered
<i>Service Manual</i>	2 (1 for the pump, 1 for the degasser)
Accessory kit (see “Accessory Kit Contents G1311-68705” on page 31)	1

Accessory Kit Contents G1311-68705

Table 6 Accessory Kit Contents G1311-68705

Description	Part Number
Capillary, pump to injection device, length 900 mm, ID 0.17 mm	G1329-87300
Seal insert tool	01018-23702
Wrench; 1/4 – 5/16 inch	8710-0510
Wrench; 14 mm	8710-1924
Hex key 4 mm	8710-2392
Corrugated Waste Tube (1.2 m)	no PN
Corrugated Waste tube (reorder number, 5 m)	5062-2463
Velocity regulator (reorder number, pack of 3)	5062-2486
PTFE Frit	01018-22707

3 Installing the Pump

Unpacking the Quaternary Pump

Accessory Kit Contents—Vacuum Degasser

Table 7 Accessory Kit Contents G1322-68705

Description	Part Number	Quantity
Syringe	5062-8534	1
Syringe adapter	9301-1337	1
Waste tube (reorder number, 5 m)	5062-2463	1.2 m
Connecting tubes labeled A to D	G1322-67300	4

Optimizing the Stack Configuration

If your module is part of a complete Agilent 1200 Series system, you can ensure optimum performance by limiting the configuration of the system stack to the following configuration. This configuration optimizes the system flow path, ensuring minimum delay volume.

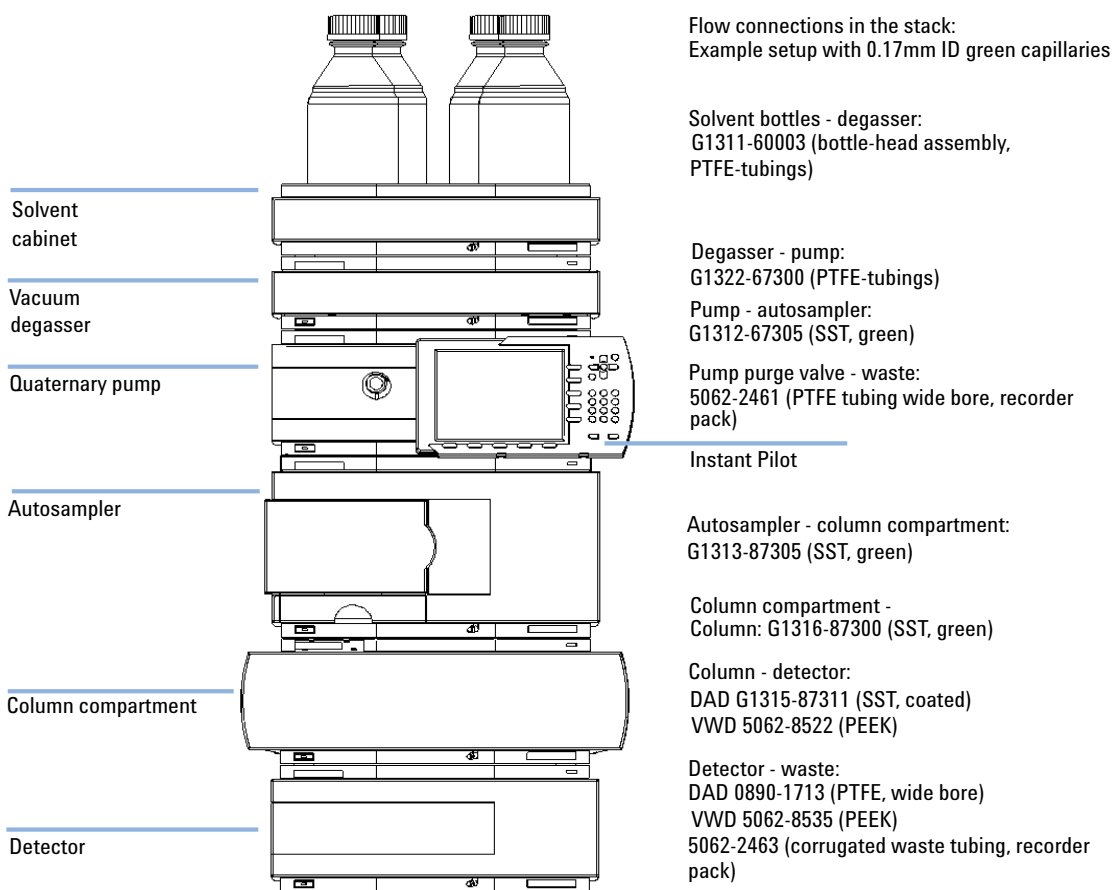

Figure 5 Recommended Stack Configuration (Front View)

3 Installing the Pump

Optimizing the Stack Configuration

NOTE

For a detailed view of the flow connections refer to the section “Flow Connections” in the product information of the individual modules.

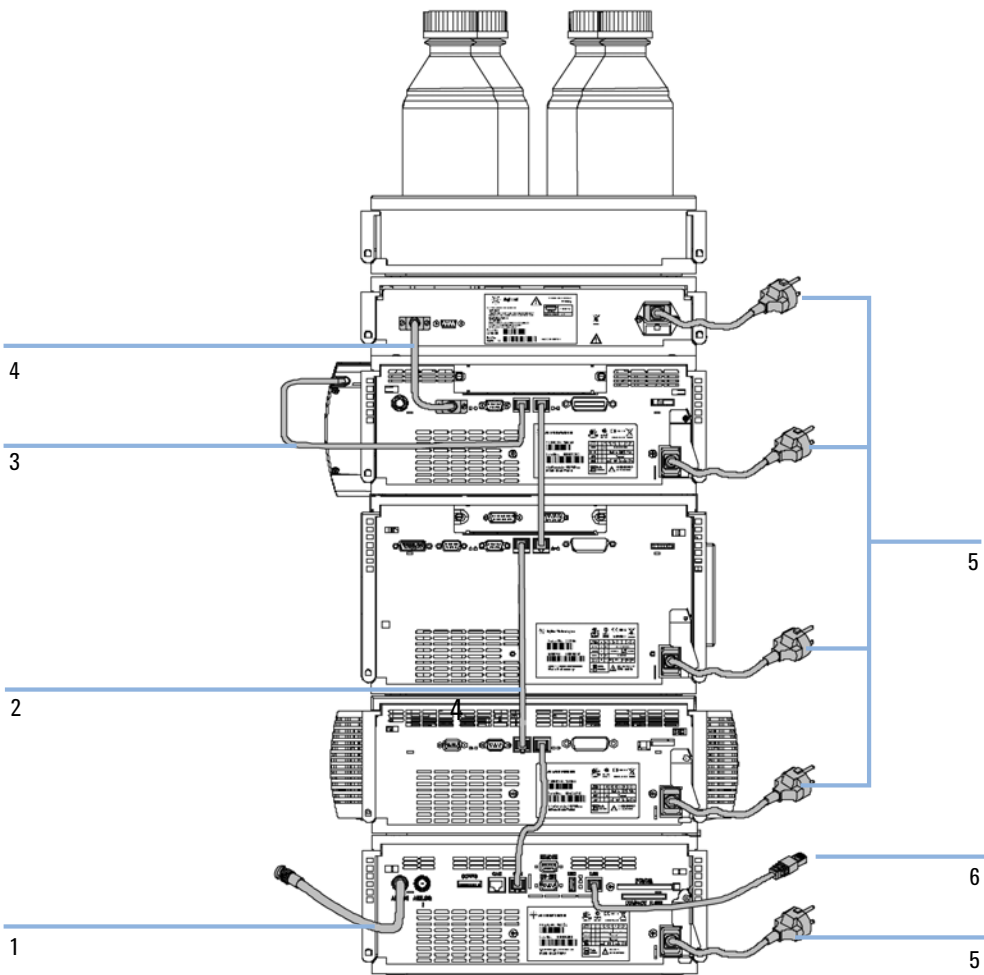

Figure 6 Recommended Stack Configuration (Rear View)

1	Analog signal to recorder, for PN see “Cable Overview” on page 120
2	CAN Bus cable for inter module communications 5181-1561 (0,5m) 5161-1519 (1,0m)
3	CAN Bus cable to handheld controller
4	Remoter cable 5061-3378 Pressure output to recorder, for PN see “Cable Overview” on page 120
5	AC power
6	GPIB or LAN to control software, for PN see “Cable Overview” on page 120

NOTE

If a single stack configuration becomes too high, e.g. if an additional module like a G1327A ALS Thermostat is added or if your bench is too high, a two stack configuration may be a better setup. Separate the stack between pump and autosampler and place the stack containing the pump on the right side of the stack containing the autosampler.

Installing the Quaternary Pump

Parts required	#	Part number	Description
	1		Pump
	1		Power cord, for other cables see text below and “Cable Overview” on page 120
			Control Software (ChemStation, EZChrom, OL, etc.)
		G4208A or G1323B	and/or a handheld controller (Instant Pilot or Control Module)

- Preparations**
- Locate bench space.
 - Provide power connections.
 - Unpack the pump.

WARNING

Module is partially energized when switched off, as long as the power cord is plugged in.

Repair work at the module can lead to personal injuries, e.g. shock hazard, when the cover is opened and the module is connected to power.

- Make sure that it is always possible to access the power plug.
- Remove the power cable from the instrument before opening the cover.
- Do not connect the power cable to the Instrument while the covers are removed.

CAUTION

"Defective on arrival" problems

If there are signs of damage, please do not attempt to install the module. Inspection by Agilent is required to evaluate if the instrument is in good condition or damaged.

- Notify your Agilent sales and service office about the damage.
- An Agilent service representative will inspect the instrument at your site and initiate appropriate actions.

- 1 Place the module on the bench in a horizontal position.

- 2 Ensure the power switch on the front of the module is OFF (switch stands out).

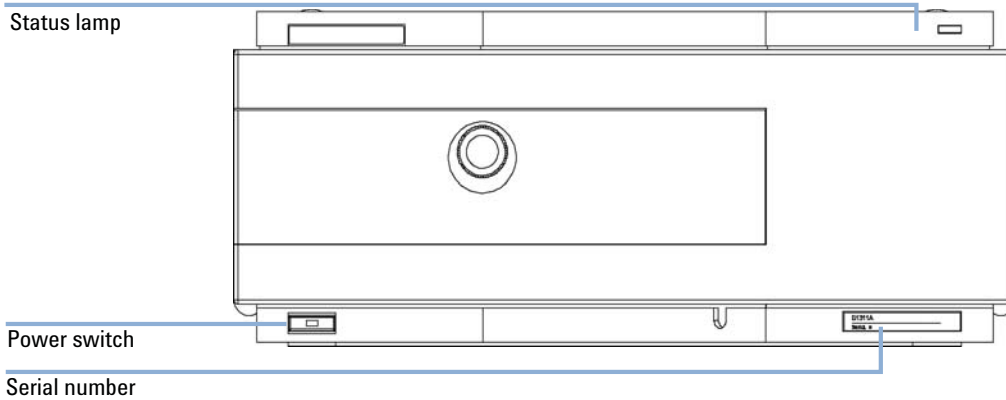
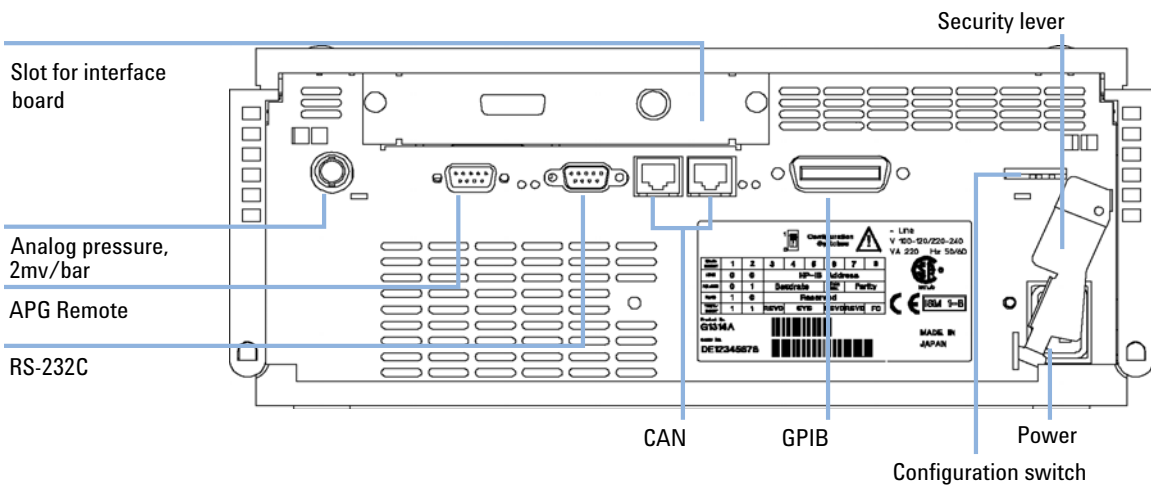

Figure 7 Front of module

- 3 At the rear of the module move the security lever to its maximum right position.
- 4 Connect the power cable to the power connector at the rear of the module. The security lever will prevent that the cover is opened while the power cord is connected to the module.
- 5 Connect the required interface cables to the quaternary pump, see “[Connecting Modules and Control Software](#)” on page 39.



3 Installing the Pump

Installing the Quaternary Pump

- 6 Connect all capillaries, solvent tubes and waste tubing (see [“Flow Connections of the Quaternary Pump”](#) on page 41).
- 7 Press power switch to turn on the module.

NOTE

The power switch stays pressed in and a green indicator lamp in the power switch is on when the module is turned on. When the line power switch stands out and the green light is off, the module is turned off.

- 8 Purge the quaternary pump (see [“Priming and Purging the System”](#) on page 44).

NOTE

The pump was shipped with default configuration settings.

Connecting Modules and Control Software

WARNING

Use of unsupplied cables

Using cables not supplied by Agilent Technologies can lead to damage of the electronic components or personal injury.

- Never use cables other than the ones supplied by Agilent Technologies to ensure proper functionality and compliance with safety or EMC regulations.
-

Connecting Agilent 1200 Series modules

- 1 Place the individual modules in a stack configuration as shown in [Figure 5](#) on page 33.
- 2 Ensure the power switches on the front of the modules are OFF (switches stand out).
- 3 Plug a CAN cable into the CAN connector at the rear of the respective module (except vacuum degasser).
- 4 Connect the CAN cable to the CAN connector of the next module, see [Figure 6](#) on page 34.
- 5 Press in the power switches to turn on the modules.

Connecting an Agilent 1200 Series Vacuum Degasser

- 1 Place the vacuum degasser in the stack of modules as shown in [Figure 5](#) on page 33.
- 2 Ensure the power switch on the front of the vacuum degasser is OFF (switch stands out).
- 3 Plug an APG cable into the APG remote connector at the rear of the module.
- 4 Connect the APG cable to the APG remote connector of the pump, see [Figure 6](#) on page 34.
- 5 Press in the power switches to turn on the vacuum degasser.

NOTE

The AUX output allows the user to monitor the vacuum level in the degasser chamber.

Connecting control software and/or control modules

- 1 Ensure the power switches on the front of the modules in the stack are OFF (switches stand out).
- 2 Plug a GPIB cable into the GPIB connector at one of the modules, preferably at the detector (MUST for the DAD).
- 3 Connect the GPIB cable to the Agilent control software in use.
- 4 Plug a CAN cable into the CAN connector of the control module.

NOTE

Do not connect the Agilent control software or the control module with the vacuum degasser.

- 5 Connect the CAN cable to the CAN connector of one of the modules.
- 6 Press in the power switches to turn on the modules.

NOTE

The Agilent control software (e.g. ChemStation, EZChrom, OL, etc.) can also be connected to the system through a LAN cable, which requires the installation of a LAN-board. For more information about connecting the control module or Agilent control software refer to the respective user manual. For connecting the Agilent 1200 Series equipment to non-Agilent 1200 Series equipment, see [“Introduction to the Quaternary Pump”](#) on page 8.

Flow Connections of the Quaternary Pump

Tools required Two wrenches 1/4–5/16 inch for capillary connections

Parts required **Description**
Other modules
Parts from accessory kit, see “[Accessory Kit Contents G1311-68705](#)” on page 31

Preparations • Pump is installed in the LC system.

WARNING

When opening capillary or tube fittings solvents may leak out.

The handling of toxic and hazardous solvents and reagents can hold health risks.

→ Please observe appropriate safety procedures (for example, goggles, safety gloves and protective clothing) as described in the material handling and safety data sheet supplied by the solvent vendor, especially when toxic or hazardous solvents are used.

1 Remove the front cover by pressing the snap fasteners on both sides.

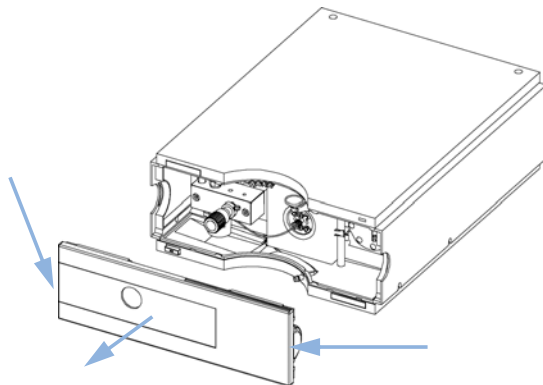

Figure 8 Removing the Front Cover

3 Installing the Pump

Flow Connections of the Quaternary Pump

- 2** Place the vacuum degasser and the solvent cabinet on top of the quaternary pump.
- 3** Put the bottle-head assemblies into solvent reservoirs containing your mobile phase and place the bottle in the solvent cabinet.
- 4** Connect the inlet tubes from the bottle-head assemblies to the inlet connectors A to D (typically the left connection of the channel) of the vacuum degasser. Fix the tubes in the tube clips of the vacuum degasser.
- 5** Connect the solvent tubes to the outlet connectors (typically right connection of the channel) of the vacuum degasser.
- 6** Connect the syringe adapter from the degasser accessory kit to the solvent tube of channel A.
- 7** Using a piece of sanding paper connect the waste tubing to the purge valve and place it into your waste system.
- 8** If the pump is not part of a Agilent 1200 Series System stack or placed on the bottom of a stack, connect the corrugated waste tube to the waste outlet of the pump leak handling system.
- 9** Connect the pump outlet capillary (pump to injection device) to the outlet of the purge valve.

10 Prime your system before first use (see “Priming and Purging the System” on page 44).

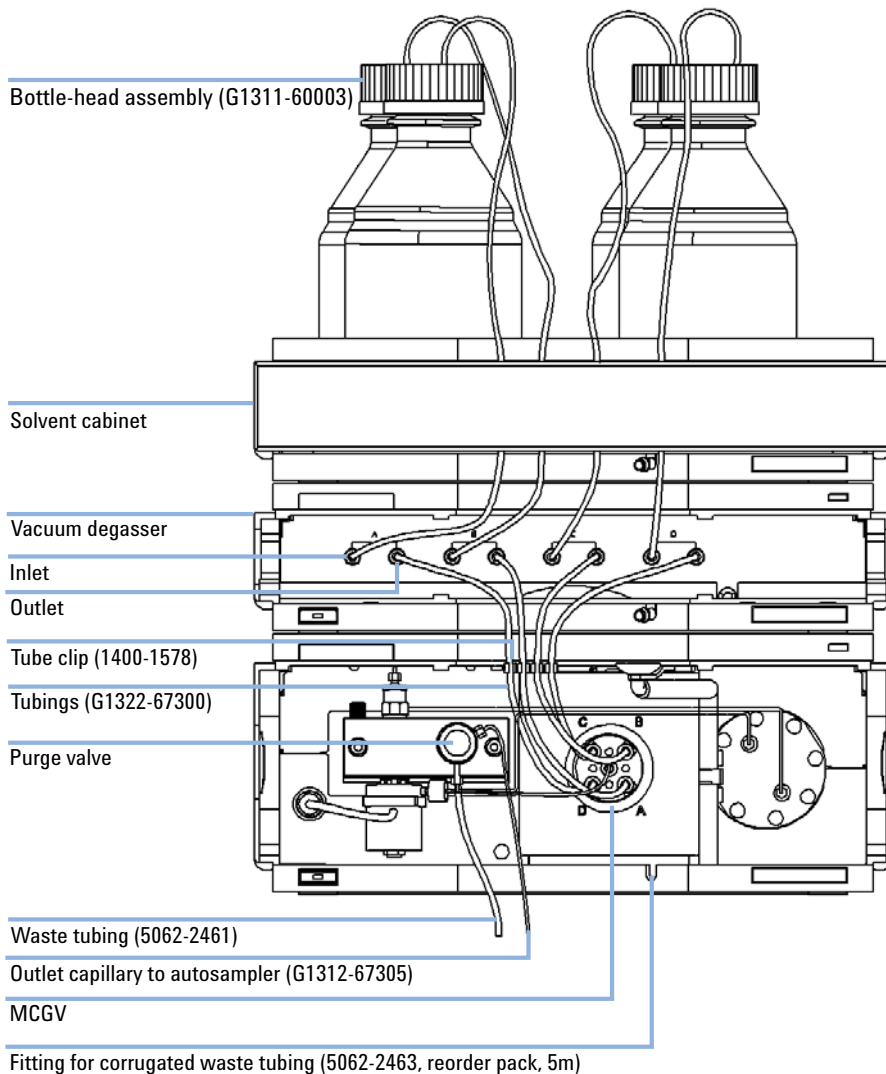

Figure 9 Flow Connections of the Quaternary Pump

Priming and Purging the System

If a degasser is installed, it can be primed either by drawing solvent through the degasser with a syringe or by pumping with the pump.

Priming the vacuum degasser or system with a syringe is recommended, when:

- vacuum degasser or connected tubings are used for the first time or vacuum tubes are empty or
- changing to solvents that are immiscible with the solvent currently in the vacuum tubes.

Priming the system by using the pump at high flow rate (3–5 ml/min) is recommended, when:

- pumping system was turned off for a length of time (for example, overnight) and if volatile solvent mixtures are used, or
- solvents have been changed.

Priming with a Syringe

WARNING

When opening capillary or tube fittings solvents may leak out.

The handling of toxic and hazardous solvents and reagents can hold health risks.

- Please observe appropriate safety procedures (for example, goggles, safety gloves and protective clothing) as described in the material handling and safety data sheet supplied by the solvent vendor, especially when toxic or hazardous solvents are used.

Before using a new degasser or new tubings for the first time:

- 1 Prime all tubings with at least 30 ml of iso-propanol no matter whether the channels will be used with organic mobile phase or with water.

NOTE

If you are changing to a solvent that is immiscible with the solvent currently in the tubing continue as follows:

- 2 Replace the current solvent with adequate organic solvent (see table above), if current solvent is organic or with water, if current solvent is an inorganic buffer or contains salt.
- 3 Disconnect solvent outlet tube of the channel that is supposed to be primed from your pump.
- 4 Connect syringe adapter to solvent outlet tube.
- 5 Push syringe adapter onto syringe.
- 6 Pull syringe plunger to draw at least 30 ml of solvent through degasser and tubing.
- 7 Replace the priming solvent with the new solvent of your choice.
- 8 Pull syringe plunger to draw at least 30 ml of solvent through degasser and tubing.
- 9 Disconnect syringe adapter from solvent tube.
- 10 Connect the solvent tube to the appropriate channel of the MCGV.
- 11 Repeat step 3 on page 45 to step 10 on page 45 for the other solvent channels.

3 Installing the Pump

Priming and Purging the System

NOTE

When priming the vacuum degasser with a syringe the solvent is drawn through the degasser tubes very quickly. The solvent at the degasser outlet will therefore not be fully degassed. Pump for approximately 10 minutes with your selected flow rate before starting any application. This will allow the vacuum degasser to properly degas the solvent in the degasser tubes.

NOTE

The pump should never be used for priming empty tubings (never let the pump run dry). Use the syringe to draw enough solvent for completely filling the tubings to the pump inlet before continuing to prime with the pump.

Priming with the Pump

When the pumping system has been turned off for a certain time (for example, overnight) oxygen will rediffuse into the solvent channels between the vacuum degasser and the pump. Solvents containing volatile ingredients will slightly lose these, if left in the degasser without flow for a prolonged period of time. Therefore priming of the vacuum degasser and the pumping system is required before starting an application.

- 1** Open the purge valve of your pump (by turning it counterclockwise) and set flow rate to 3-5 ml/min.
- 2** Flush the vacuum degasser and all tubes with at least 30 ml of solvent.
- 3** Set flow to required value of your application and close the purge valve.
- 4** Pump for approximately 10 minutes before starting your application.
- 5** Repeat step 1 to step 4 for other solvent channels, where needed.

Table 8 Choice of Priming Solvents for Different Purposes

Activity	Solvent	Comments
After an installation	Isopropanol	Best solvent to flush air out of the system
When switching between reverse phase and normal phase (both times)	Isopropanol	Best solvent to flush air out of the system
After an installation	Ethanol or Methanol	Alternative to Isopropanol (second choice) if no Isopropanol is available
To clean the system when using buffers	Bidistilled water	Best solvent to re-dissolve buffer crystals
After a solvent change	Bidistilled water	Best solvent to re-dissolve buffer crystals
After the installation of normal phase seals (P/N 0905-1420)	Hexane + 5% Isopropanol	Good wetting properties

3 Installing the Pump

Priming and Purging the System

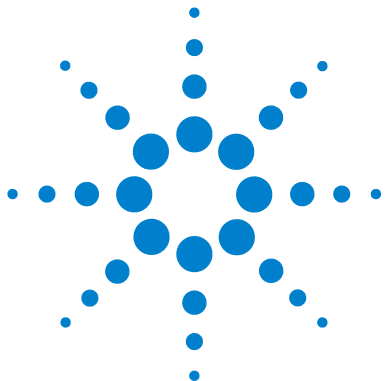

4 Using the Quaternary Pump

Hints for Successful Use of the Quaternary Pump 50

Solvent Information 51

Prevent Blocking of Solvent Filters 52

Algae Growth in HPLC Systems 53

How to Prevent and/or Reduce the Algae Problem 54



Hints for Successful Use of the Quaternary Pump

- Always place the solvent cabinet with the solvent bottles on top of the quaternary pump (or at a higher level).
- When using salt solutions and organic solvents in the Agilent 1200 Series Quaternary Pump it is recommended to connect the salt solution to one of the bottom gradient valve ports and the organic solvent to one of the upper gradient valve ports. It is best to have the organic channel directly above the salt solution channel. Regular flushing with water of all MGV channels is recommended to remove all possible salt deposits in the valve ports.
- Before operating the quaternary pump flush the vacuum degasser with at least two volumes (30 ml), especially when turned off for a certain length of time (for example, during the night) and volatile solvent mixtures are used in the channels (see [“Priming and Purging the System”](#) on page 44).
- Prevent blocking of solvent inlet filters (never use the pump without solvent inlet filter). Growth of algae should be avoided (see [“Prevent Blocking of Solvent Filters”](#) on page 52).
- Check purge valve frit and column frit in regular time intervals. A blocked purge valve frit can be identified by black or yellow layers on its surface or by a pressure greater than 10 bar, when pumping distilled water at a rate of 5 ml/min with an open purge valve.
- When using the quaternary pump at low flow rates (for example, 0.2 ml/min) check all 1/16-inch fittings for any signs of leaks.
- Whenever exchanging the pump seals the purge valve frit should be exchanged, too.
- When using buffer solutions, flush the system with water before switching it off. The seal wash option should be used when buffer concentrations of 0.1 Molar or higher will be used for long time periods.
- Check the pump plungers for scratches when changing the plunger seals. Scratched plungers will lead to micro leaks and will decrease the lifetime of the seal.
- Pressurize the system according to the wear in procedure after changing the plunger seals (see [“Exchanging the Pump Seals and Seal Wear-in Procedure”](#) on page 89).

Solvent Information

Always filter solvents through 0.4 µm filters, small particles can permanently block the capillaries and valves. Avoid the use of the following steel-corrosive solvents:

- Solutions of alkali halides and their respective acids (for example, lithium iodide, potassium chloride, and so on).
- High concentrations of inorganic acids like sulfuric and nitric acid, especially at higher temperatures (replace, if your chromatography method allows, by phosphoric acid or phosphate buffer which are less corrosive against stainless steel).
- Halogenated solvents or mixtures which form radicals and/or acids, for example:

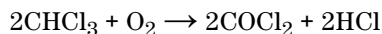

This reaction, in which stainless steel probably acts as a catalyst, occurs quickly with dried chloroform if the drying process removes the stabilizing alcohol.

- Chromatographic grade ethers, which can contain peroxides (for example, THF, dioxane, di-isopropylether). Such ethers should be filtered through dry aluminium oxide which adsorbs the peroxides.
- Mixtures of carbon tetrachloride with 2-propanol or THF dissolve stainless steel.

Prevent Blocking of Solvent Filters

Contaminated solvents or algae growth in the solvent bottle will reduce the lifetime of the solvent filter and will influence the performance of the module. This is especially true for aqueous solvents or phosphate buffers (pH 4 to 7). The following suggestions will prolong lifetime of the solvent filter and will maintain the performance of the module.

- Use a sterile, if possible amber, solvent bottle to slow down algae growth.
- Filter solvents through filters or membranes that remove algae.
- Exchange solvents every two days or refilter.
- If the application permits add 0.0001-0.001M sodium azide to the solvent.
- Place a layer of argon on top of your solvent.
- Avoid exposure of the solvent bottle to direct sunlight.

NOTE

Never use the system without solvent filter installed.

Algae Growth in HPLC Systems

The presence of algae in HPLC systems can cause a variety of problems that may be incorrectly diagnosed as instrument or application problems. Algae grow in aqueous media, preferably in a pH range of 4-8. Their growth is accelerated by buffers, for example phosphate or acetate. Since algae grow through photosynthesis, light will also stimulate their growth. Even in distilled water small-sized algae grow after some time.

Instrumental Problems Associated With Algae

Algae deposit and grow everywhere within the HPLC system causing:

- Deposits on ball valves, inlet or outlet, resulting in unstable flow or total failure of the pump.
- Small pore solvent inlet filters to plug, resulting in unstable flow or total failure of the pump.
- Small pore high pressure solvent filters, usually placed before the injector to plug resulting in high system pressure.
- Column filters to plug giving high system pressure.
- Flow cell windows of detectors to become dirty resulting in higher noise levels (since the detector is the last module in the flow path, this problem is less common).

Symptoms Observed with the Agilent 1200 Series HPLC

In contrast to the HP 1090 and HP 1050 Series HPLC systems which use helium degassing, algae have a better chance to grow in systems such as the Agilent 1200 Series where helium is not used for degassing (most algae need oxygen and light for growth).

The presence of algae in the Agilent 1200 Series can cause the following to occur:

- PTFE frits, part number 01018-22707, (purge valve assembly) and column filter blockage causing increased system pressure. Algae appear as white or yellowish-white deposits on filters. Typically black particles from the

normal wear of the piston seals do not cause the PTFE frits to block over short-term usage. Please refer to the section “[Exchanging the Purge Valve Frit or the Purge Valve](#)” on page 85 in this manual.

- Short lifetime of solvent filters (bottle head assembly). A blocked solvent filter in the bottle, especially when only partly blocked, is more difficult to identify and may show up as gradient performance problems, intermittent pressure fluctuations etc.
- Algae growth may also be the possible source for failures of the ball valves and other components in the flow path.

How to Prevent and/or Reduce the Algae Problem

- Always use freshly prepared solvents, especially use demineralized water which was filtered through about 0.2 µm filters.
- Never leave mobile phase in the instrument for several days without flow.
- Always discard “old” mobile phase.
- Use the amber solvent bottle (part number 9301-1450) supplied with the instrument for your aqueous mobile phase.
- If possible add a few mg/l sodium azide or a few percent organic solvent to the aqueous mobile phase.

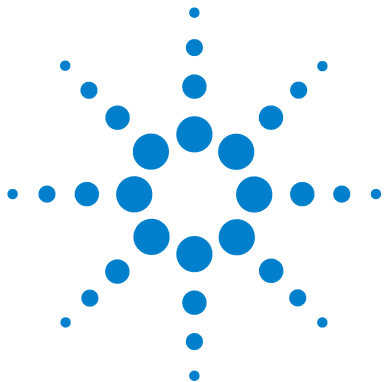

5 Optimizing Performance

Operational Hints for the Vacuum Degasser 56

Operational Hints for the Multi Channel Gradient Valve (MCGV) 57

When to use the Seal Wash Option 58

When to Use Alternative Seals 59

Optimize the Compressibility Compensation Setting 60



Operational Hints for the Vacuum Degasser

If you are using the vacuum degasser for the first time, if the vacuum degasser was switched off for any length of time (for example, overnight), or if the vacuum degasser lines are empty, you should prime the vacuum degasser before running an analysis.

The vacuum degasser can be primed either by drawing solvent through the degasser with a syringe or by pumping with the quaternary pump.

Priming the degasser with a syringe is recommended, when:

- vacuum degasser is used for the first time, or vacuum tubes are empty, or
- changing to solvents that are immiscible with the solvent currently in the vacuum tubes.

Priming the vacuum degasser by using the quaternary pump at high flow rate is recommended, when:

- quaternary pump was turned off for a length of time (for example, during night) and volatile solvent mixtures are used, or
- solvents have been changed.

For more information see the *Service Manual* for the Agilent 1200 Series vacuum degasser.

Operational Hints for the Multi Channel Gradient Valve (MCGV)

In a mixture of salt solutions and organic solvent the salt solution might be well dissolved in the organic solvent without showing precipitations. However in the mixing point of the gradient valve, at the boundary between the two solvents, micro precipitation is possible. Gravity forces the salt particles to fall down. Normally the A channel of the valve is used for the aqueous/salt solution and the B channel of the pump is used for the organic solvent. If used in this configuration the salt will fall back into the salt solution and will be dissolved. When using the pump in a different configuration (e.g., D - salt solution, A -organic solvent) the salt can fall into the port of the organic solvent and may lead to performance problems.

NOTE

When using salt solutions and organic solvents in the Agilent 1200 Series Quaternary Pump it is recommended to connect the salt solution to one of the bottom ports and the organic solvent to one of the upper gradient valve ports. It is best to have the organic channel directly above the salt solution channel. Regular flushing with water of all MCGV channels is recommended to remove all possible salt deposits in the valve ports.

When to use the Seal Wash Option

Highly-concentrated buffer solutions will reduce the lifetime of the seals and plungers in your pump. The seal wash option allows to maintain the seal lifetime by flushing the back side of the seal with a wash solvent.

The seal wash option is strongly recommended when buffer concentrations of 0.1 Molar or higher will be used for long time periods in the pump.

The seal wash option can be ordered by quoting part number 01018-68722 (kit contains all parts needed for one pump head). The active seal wash option kit can be ordered by quoting part number G1311-68711.

The seal wash option comprises a support ring, secondary seal, gasket and seal keeper for both plunger sides. A wash bottle filled with water /isopropanol (90/10) should be placed above the pump in the solvent cabinet and gravity will maintain a flow through the pump head removing all possible buffer crystals from the back of the pump seal. For the active seal wash a peristaltic pump is pumping the solvent through the pump head.

NOTE

Running dry is the worst case for a seal and drastically reduces its lifetime. The seal will build up sticky layers on the surface of the plunger. These sticky layers will also reduce the lifetime of the primary seal. Therefore the tubes of the wash option should always be filled with solvent to prolong the lifetime of the wash seal. Always use a mixture of bidistilled water (90 %) and isopropanol (10 %) as wash solvent. This mixture prevents bacteria growth in the wash bottle and reduces the surface tension of the water.

For information on the installation of the active seal wash option refer to [“Installing the Seal Wash Option”](#) on page 94.

When to Use Alternative Seals

The standard seal for the pump can be used for most applications. However applications that use normal phase solvents (for example, hexane) are not suited for the standard seal and require a different seal when used for a longer time in the pump.

For applications that use normal phase solvents (for example, hexane) we recommend the use of the polyethylene seals, part number 0905-1420 (pack of 2). These seals have less abrasion compared to the standard seals.

NOTE

Polyethylene seals have a limited pressure range 0–200 bar. When used above 200 bar their lifetime will be significantly reduced. **DO NOT** apply the seal wear-in procedure performed with new standard seals at 400 bar.

Optimize the Compressibility Compensation Setting

The compressibility compensation default setting is 100×10^{-6} /bar for the quaternary pump. This setting represents an average value. Under normal conditions the default setting reduces the pressure pulsation to values (below 1% of system pressure) that will be sufficient for most applications and for all gradient analyses. For applications using sensitive detectors, the compressibility settings can be optimized by using the values for the various solvents described in [Table 9](#) on page 61. If the solvent in use is not listed in the compressibility tables, when using isocratic mixtures of solvents and if the default settings are not sufficient for your application the following procedure can be used to optimize the compressibility settings.

NOTE

When using mixtures of solvents it is not possible to calculate the compressibility of the mixture by interpolating the compressibility values of the pure solvents used in that mixture or by applying any other calculation. In these cases the following empirical procedure has to be applied to optimize your compressibility setting.

- 1 Start the pump with the required flow rate.
- 2 Before starting the optimization procedure, the flow must be stable. Use degassed solvent only.
- 3 Your pump must be connected to a control software (e.g. ChemStation, EZChrom, OL, etc.) or handheld controller with which the pressure and %-ripple can be monitored, otherwise connect a signal cable between the pressure output of the pump and a recording device (for example, 339X integrator) and set parameters.
Zero 50%
Att 2³ Chart
Speed 10 cm/min
- 4 Start the recording device with the plot mode.
- 5 Starting with a compressibility setting of 10×10^{-6} /bar increase the value in steps of 10. Re-zero the integrator as required. The compressibility compensation setting that generates the smallest pressure ripple is the optimum value for your solvent composition.

Table 9 Solvent Compressibility

Solvent (pure)	Compressibility (10-6/bar)
Acetone	126
Acetonitrile	115
Benzene	95
Carbon tetrachloride	110
Chloroform	100
Cyclohexane	118
Ethanol	114
Ethyl acetate	104
Heptane	120
Hexane	150
Isobutanol	100
Isopropanol	100
Methanol	120
1-Propanol	100
Toluene	87
Water	46

5 Optimizing Performance

Optimize the Compressibility Compensation Setting

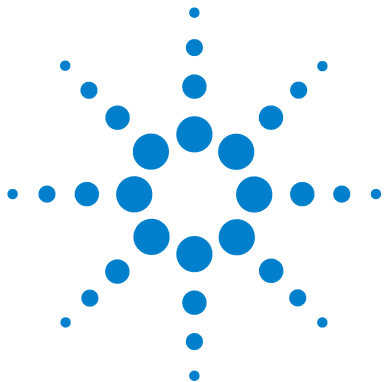

6 Troubleshooting and Test Functions

Agilent Lab Advisor Software 64

Overview of the Pump's Indicators and Test Functions 65

Status Indicators 66

 Power Supply Indicator 66

 Instrument Status Indicator 67

User Interfaces 68



Agilent Lab Advisor Software

The Agilent Lab Advisor Software is a standalone product that can be used with or without data system. Agilent Lab Advisor helps to manage the lab for high quality chromatographic results and can monitor in real time a single Agilent LC or all the Agilent GCs and LCs configured on the lab intranet.

Agilent Lab Advisor provides diagnostic capabilities for all Agilent 1200 Series HPLC modules. This includes tests and calibrations procedures as well as the different injector steps to perform all the maintenance routines.

Agilent Lab Advisor also allows users to monitor the status of their LC instruments. The Early Maintenance Feedback (EMF) feature helps to carry out preventive maintenance. In addition, users can generate a status report for each individual LC instrument. The tests and diagnostic features as provided by the Agilent Lab Advisor Software may differ from the descriptions in this manual. For details refer to the Agilent Lab Advisor help files.

This manual provides lists with the names of Error Messages, Not Ready messages, and other common issues.

Overview of the Pump's Indicators and Test Functions

Status Indicators

The quaternary pump is provided with two status indicators which indicate the operational state (prerun, run, and error states) of the quaternary pump. The status indicators provide a quick visual check of the operation of the quaternary pump (see [“Status Indicators”](#) on page 66).

Error Messages

In the event of an electronic, mechanical or hydraulic failure, the instrument generates an error message in the user interface. For details on error messages and error handling, please refer to the Agilent Lab Monitor & Diagnostic Software.

Pressure Test

The pressure test is a quick test designed to determine the pressure tightness of the system.

Leak Test

The leak test is a diagnostic test designed to determine the pressure tightness of the quaternary pump.

Status Indicators

Two status indicators are located on the front of the module. The lower left one indicates the power supply status, the upper right one indicates the module status.

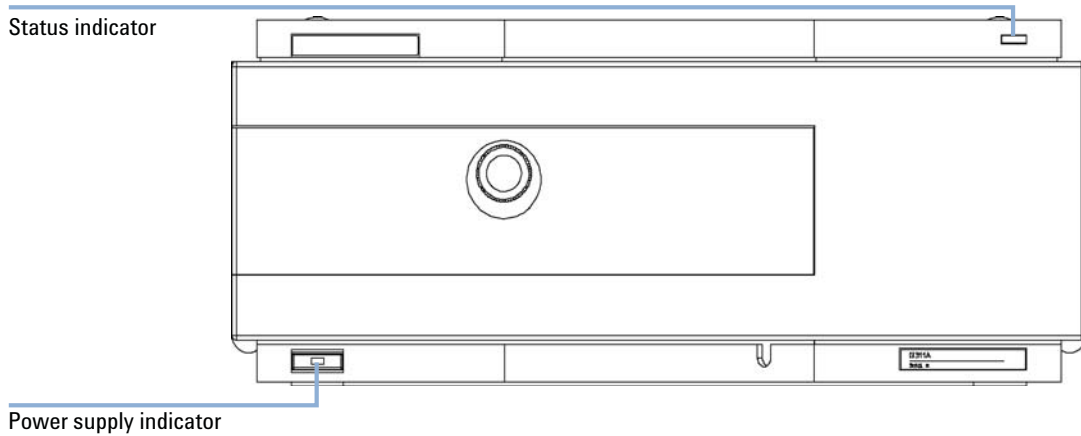

Figure 10 Location of Status Indicators

Power Supply Indicator

The power supply indicator is integrated into the main power switch. When the indicator is illuminated (*green*) the power is ON.

When the indicator is off, the module is turned OFF. Otherwise check power connections, availability of power or check functioning of the power supply.

Instrument Status Indicator

The instrument status indicator indicates one of four possible instrument conditions:

- When the status indicator is *OFF* (and power switch light is ON), the module is in *aprerun* condition, and is ready to begin an analysis.
- A *green* status indicator, indicates the module is performing an analysis (*run mode*).
- A *yellow* indicator indicates a *not-ready* condition. The module is in a not-ready state when it is waiting for a specific condition to be reached or completed (for example, immediately after changing a setpoint), or while a self-test procedure is running.
- An *error* condition is indicated when the status indicator is *red*. An error condition indicates the module has detected an internal problem which affects correct operation of the module. Usually, an error condition requires attention (for example, leak, defective internal components). An error condition always interrupts the analysis.
- A *flashing yellow* status indicator indicates that the module is in its resident mode. Call your local service provider for assistance upon observing this error condition.
- A *flashing red* status indicator indicates a severe error during the *startup* procedure of the module. Call your local service provider for assistance upon observing this error condition.

User Interfaces

Depending on the User Interface, the available test vary. Some descriptions are only available in the Service Manual.

Table 10 Test Functions available vs. User Interface

Test	ChemStation	Instant Pilot G4208A	Control Module G1323B	Agilent Lab Monitor & Diagnostic Software
Pressure Test	Yes	Yes	Yes	Yes
Leak Test	Yes	Yes	Yes	Yes

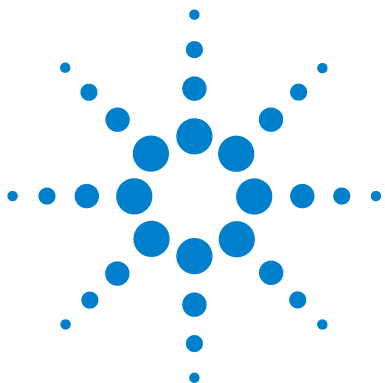

7 Maintenance

Introduction to Repairing the Pump	70
Simple Repairs	70
Exchanging Internal Parts	70
Warnings and Cautions	71
Using the ESD Strap	72
Cleaning the Module	72
Early Maintenance Feedback (EMF)	73
EMF Counters	73
Using the EMF Counters	74
Overview of Repairing the Pump	75
Simple Repairs	77
Checking and Cleaning the Solvent Filter	78
Exchanging the Active Inlet Valve	79
Exchanging the Active Inlet Valve Cartridge	81
Exchanging the Outlet Ball Valve	83
Exchanging the Purge Valve Frit or the Purge Valve	85
Removing the Pump Head Assembly	88
Exchanging the Pump Seals and Seal Wear-in Procedure	89
Exchanging the Plungers	92
Installing the Seal Wash Option	94
Exchanging the Wash Seals	97
Reinstalling the Pump Head Assembly	100
Exchanging the Multi-Channel Gradient Valve (MCGV)	101
Exchanging the Optional Interface Board	103
Replacing the Module's Firmware	104



Introduction to Repairing the Pump

Simple Repairs

The module is designed for easy repair. The most frequent repairs such as plunger seal change and purge valve frit change can be done from the front of the module with the module in place in the system stack.

These repairs are described in [“Simple Repairs”](#) on page 77.

Exchanging Internal Parts

Some repairs may require exchange of defective internal parts. Exchange of these parts requires removing the module from the stack, removing the covers, and disassembling the module. The security lever at the power input socket prevents that the module cover is taken off when line power is still connected.

Warnings and Cautions

WARNING

Module is partially energized when switched off, as long as the power cord is plugged in.

Repair work at the module can lead to personal injuries, e.g. shock hazard, when the cover is opened and the module is connected to power.

- Make sure that it is always possible to access the power plug.
 - Remove the power cable from the instrument before opening the cover.
 - Do not connect the power cable to the Instrument while the covers are removed.
-

WARNING

Sharp metal edges

Sharp-edged parts of the equipment may cause injuries.

- To prevent personal injury, be careful when getting in contact with sharp metal areas.
-

WARNING

When opening capillary or tube fittings solvents may leak out.

The handling of toxic and hazardous solvents and reagents can hold health risks.

- Please observe appropriate safety procedures (for example, goggles, safety gloves and protective clothing) as described in the material handling and safety data sheet supplied by the solvent vendor, especially when toxic or hazardous solvents are used.
-

CAUTION

Electronic boards are static sensitive and should be handled with care so as not to damage them. Touching electronic boards and components can cause electrostatic discharge (ESD).

ESD can damage electronic boards and components.

- Be sure to hold the board by the edges and do not touch the electrical components. Always use an ESD protection (for example, an ESD wrist strap) when handling electronic boards and components.
-

Using the ESD Strap

Electronic boards are sensitive to electronic discharge (ESD). In order to prevent damage, always use an ESD strap when handling electronic boards and components.

- 1 Unwrap the first two folds of the band and wrap the exposed adhesive side firmly around your wrist.
- 2 Unroll the rest of the band and peel the liner from the copper foil at the opposite end.
- 3 Attach the copper foil to a convenient and exposed electrical ground.

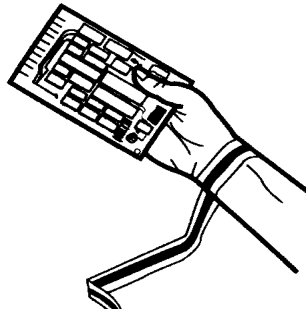

Figure 11 Using the ESD Strap

Cleaning the Module

WARNING

Liquid dripping into the electronic compartment of your module.

Liquid in the module electronics can cause shock hazard and damage the module.

- Do not use an excessively damp cloth during cleaning.
- Drain all solvent lines before opening any fittings.

The module case should be kept clean. Cleaning should be done with a soft cloth slightly dampened with water or a solution of water and a mild detergent. Do not use an excessively damp cloth that liquid can drip into the module.

Early Maintenance Feedback (EMF)

Maintenance requires the exchange of components in the flow path which are subject to mechanical wear or stress. Ideally, the frequency at which components are exchanged should be based on the intensity of usage of the instrument and the analytical conditions, and not on a predefined time interval. The early maintenance feedback (EMF) feature monitors the usage of specific components in the instrument, and provides feedback when the user-settable limits have been exceeded. The visual feedback in the user interface provides an indication that maintenance procedures should be scheduled.

EMF Counters

The pump provides a series of EMF counters for the pump head. Each counter increments with pump use, and can be assigned a maximum limit which provides visual feedback in the user interface when the limit is exceeded. Each counter can be reset to zero after maintenance has been done. The pump provides the following EMF counters:

- Pump Liquimeter
- Pump seal wear

Pump Liquimeter

The pump liquimeter displays the total volume of solvent pumped by the pump head since the last reset of the counters. The pump liquimeter can be assigned an EMF (maximum) limit. When the limit is exceeded, the EMF flag in the user interface is displayed.

Seal Wear Counters

The seal wear counters display a value derived from pressure and flow (both contribute to seal wear). The values increment with pump usage until the counters are reset after seal maintenance. Both seal wear counters can be assigned an EMF (maximum) limit. When the limit is exceeded, the EMF flag in the user interface is displayed.

Using the EMF Counters

The user-settable EMF limits for the EMF counters enable the early maintenance feedback to be adapted to specific user requirements. The wear of pump components is dependent on the analytical conditions, therefore, the definition of the maximum limits need to be determined based on the specific operating conditions of the instrument.

Setting the EMF Limits

The setting of the EMF limits must be optimized over one or two maintenance cycles. Initially, no EMF limit should be set. When performance indicates maintenance is necessary, take note of the values displayed by pump liquimeter and seal wear counters. Enter these values (or values slightly less than the displayed values) as EMF limits, and then reset the EMF counters to zero. The next time the EMF counters exceed the new EMF limits, the EMF flag will be displayed, providing a reminder that maintenance needs to be scheduled.

Overview of Repairing the Pump

Figure 12 shows the main assemblies of the quaternary pump. The pump head and its parts do require normal maintenance (for example, seal exchange) and can be accessed from the front (simple repairs). Replacing internal parts will require to remove the quaternary pump from its stack and to open the top cover.

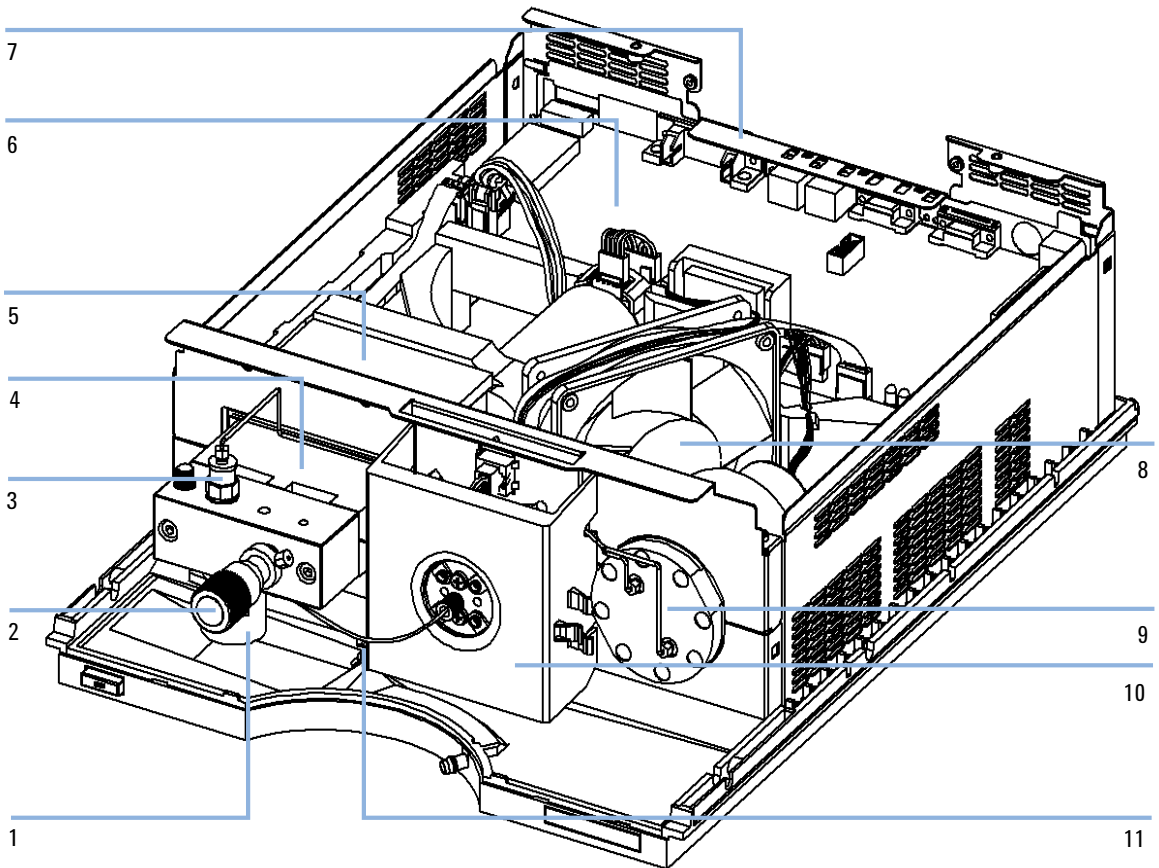

Figure 12 Overview of Repair Procedures

7 Maintenance

Overview of Repairing the Pump

1	Active inlet valve, “Exchanging the Active Inlet Valve” on page 79
2	Purge valve, “Exchanging the Purge Valve Frit or the Purge Valve” on page 85
3	Outlet ball valve, “Exchanging the Outlet Ball Valve” on page 83
4	Pump head, “Reinstalling the Pump Head Assembly” on page 100
5	Pump drive
6	LPM board
7	Power supply
8	Fan
9	Damping unit
10	MCGV, “Exchanging the Multi-Channel Gradient Valve (MCGV)” on page 101
11	Leak sensor

Simple Repairs

The procedures described in this section can be done with the quaternary pump in place in the system stack.

Table 11 Simple Repair Procedures

Procedure	Typical Frequency	Notes
“Checking and Cleaning the Solvent Filter” on page 78	If solvent filter is blocked	Gradient performance problems, intermittent pressure fluctuations
“Exchanging the Active Inlet Valve” on page 79	If internally leaking	Pressure ripple unstable, run leak test for verification
“Exchanging the Outlet Ball Valve” on page 83	If internally leaking	Pressure ripple unstable, run leak test for verification
“Exchanging the Purge Valve Frit or the Purge Valve” on page 85	If internally leaking	Solvent dripping out of waste outlet when valve closed
“Exchanging the Purge Valve Frit or the Purge Valve” on page 85	If the frit shows indication of contamination or blockage	A pressure drop of > 10 bar across the frit (5 ml/min H ₂ O with purge open) indicates blockage
“Exchanging the Pump Seals and Seal Wear-in Procedure” on page 89	If pump performance indicates seal wear	Leaks at lower pump head side, unstable retention times, pressure ripple unstable — run leak test for verification
“Exchanging the Plungers” on page 92	If scratched	Seal life time shorter than normally expected — check plungers while changing the seals
“Installing the Seal Wash Option” on page 94	If seals show indication of leaks	Leaks at lower pump head side, loss of wash solvent
“Exchanging the Optional Interface Board” on page 103	If defective	Error condition, indicated by red status indicator

Checking and Cleaning the Solvent Filter

CAUTION

Small particles can permanently block the capillaries and valves of the module.

Damage of the module.

→ Always filter solvents.

→ Never use the module without solvent inlet filter.

NOTE

If the filter is in good condition the solvent will freely drip out of the solvent tube (hydrostatic pressure). If the solvent filter is partly blocked only very little solvent will drip out of the solvent tube.

Cleaning the Solvent Filter

When

If solvent filter is blocked

Parts required

#	Description
1	Concentrated nitric acid (35%)
1	Bidistilled water
1	Beaker

Preparations

- Remove solvent inlet tube from the adapter at the AIV
- 1 Remove the blocked solvent filter from the bottle-head assembly and place it in a beaker with concentrated nitric acid (35%) for one hour.
 - 2 Thoroughly flush the filter with bidistilled water (remove all nitric acid, some capillary columns can be damaged by nitric acid).
 - 3 Replace the filter.

Exchanging the Active Inlet Valve

When If internally leaking (backflow)

Tools required

- Wrench 14 mm
- Pair of Tweezers

Parts required

#	Part number	Description
1	G1312-60025	Active inlet valve body
1	5062-8562	Valve cartridge (400 bar)

Preparations Switch off pump at the main power switch and unplug the power cable

- 1 Remove the front cover.
- 2 Unplug the active inlet valve cable from the connector.
- 3 Disconnect the solvent inlet tube at the inlet valve (be aware that solvent may leak out of the tube due to hydrostatic flow).
- 4 Unscrew the adapter from the active inlet valve.
- 5 Using a 14 mm wrench loosen the active inlet valve and remove the valve from pump head.

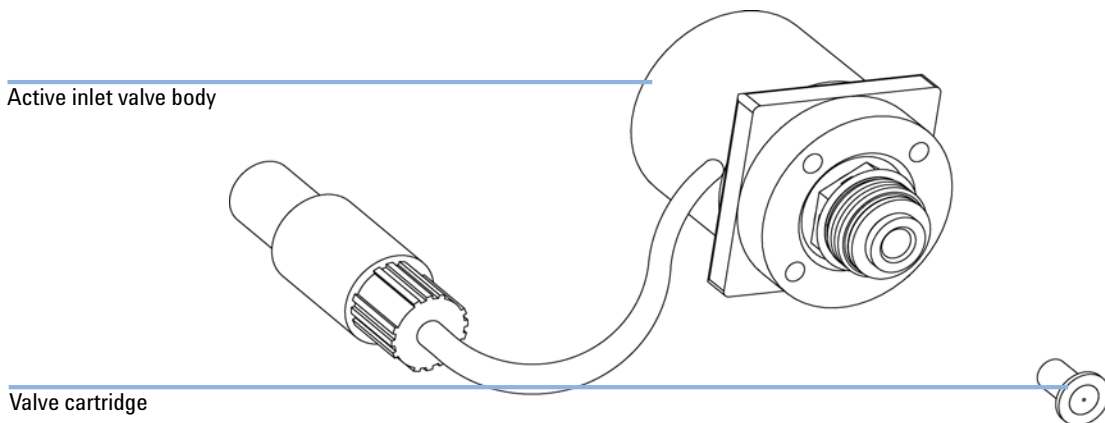

Figure 13 Active Inlet Valve Assembly

- 6 Insert the new valve into the pump head. Using the 14 mm wrench turn the nut until it is hand tight.

7 Maintenance

Simple Repairs

- 7 Position the valve so that the solvent inlet tube connection points towards the front.
- 8 Using the 14 mm wrench tighten the nut by turning the valve in its final position (not more than a quarter turn).
- 9 Reconnect the adapter at the active inlet valve.
- 10 Reconnect the solvent inlet tube to the adapter. Reconnect the active inlet valve cable to the connector in the Z-panel.
- 11 Reinstall the front cover.

NOTE

After an exchange of the valve it may take several ml of pumping with the solvent used in the current application, before the flow stabilizes at a %-ripple as low as it used to be when the system was still working properly.

Exchanging the Active Inlet Valve Cartridge

When	If internally leaking (backflow)		
Tools required	<ul style="list-style-type: none"> • Wrench 14 mm • Pair of Tweezers 		
Parts required	#	Part number	Description
	1	G1312-60025	Active inlet valve body
	1	5062-8562	Valve cartridge (400 bar)
Preparations	Switch off pump at the main power switch and unplug the power cable		

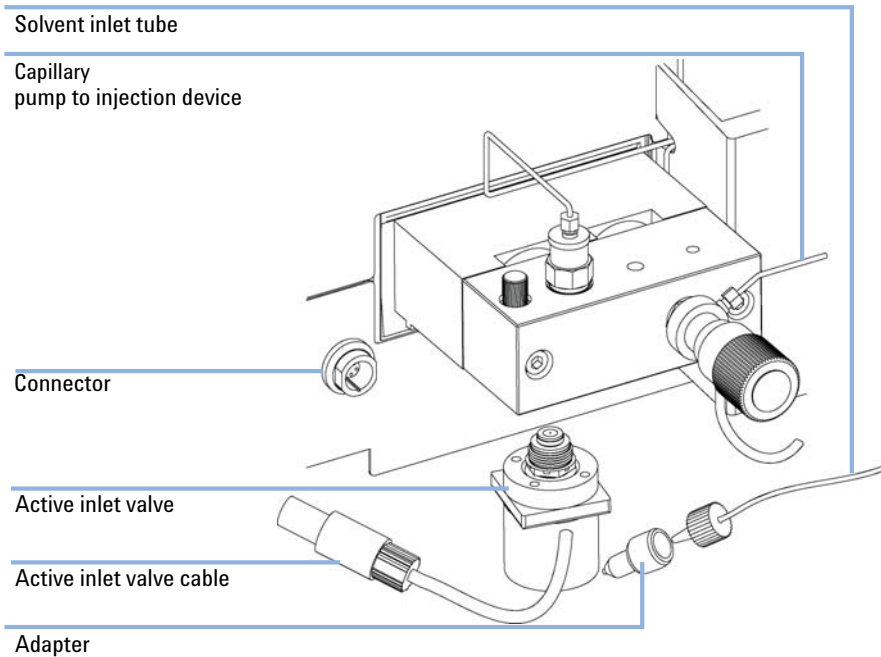

Figure 14 Exchanging the Active Inlet Valve

- 1 Remove the front cover.
- 2 Unplug the active inlet valve cable from the connector.

7 Maintenance

Simple Repairs

- 3 Disconnect the solvent inlet tube at the inlet valve (be aware that solvent may leak out of the tube due to hydrostatic flow).
- 4 Unscrew the adapter from the active inlet valve.
- 5 Using a 14 mm wrench loosen the active inlet valve and remove the valve from pump head.
- 6 Using a pair of tweezers remove the valve cartridge from the actuator assembly.
- 7 Before inserting the new valve cartridge clean the area in the actuator assembly. Flush the cartridge area thoroughly with alcohol.
- 8 Insert a new valve cartridge into the actuator assembly (make sure the valve cartridge is fully inserted into the actuator assembly).
- 9 Insert the valve into the pump head. Using the 14 mm wrench turn the nut until it is hand tight.
- 10 Position the valve so that the solvent inlet tube connection points towards the front.
- 11 Using the 14 mm wrench tighten the nut by turning the valve in its final position (not more than a quarter turn).
- 12 Reconnect the adapter at the active inlet valve.
- 13 Reconnect the solvent inlet tube to the adapter. Reconnect the active inlet valve cable to the connector in the Z-panel.
- 14 Reinstall the front cover.

NOTE

After an exchange of the valve cartridge it may take several ml of pumping with the solvent used in the current application, before the flow stabilizes at a %-ripple as low as it used to be when the system was still working properly.

Exchanging the Outlet Ball Valve

When	If internally leaking		
Tools required	<ul style="list-style-type: none"> • Wrench 1/4 inch • Wrench 14 mm 		
Parts required	#	Part number	Description
	1	G1311-60012	Outlet ball valve
Preparations	<ul style="list-style-type: none"> • Switch off pump at the main power switch • Remove the front cover 		

NOTE

Before exchanging the outlet ball valve you can try to clean it in a sonic bath for 5 – 10 minutes. Place the valve in an upright position in a small beaker with alcohol.

- 1 Using a 1/4 inch wrench disconnect the valve capillary from the outlet ball valve.
- 2 Using the 14 mm wrench loosen the valve and remove it from the pump body.
- 3 Check that the new valve is assembled correctly and that the gold seal is present (if the gold seal is deformed, it should be replaced).

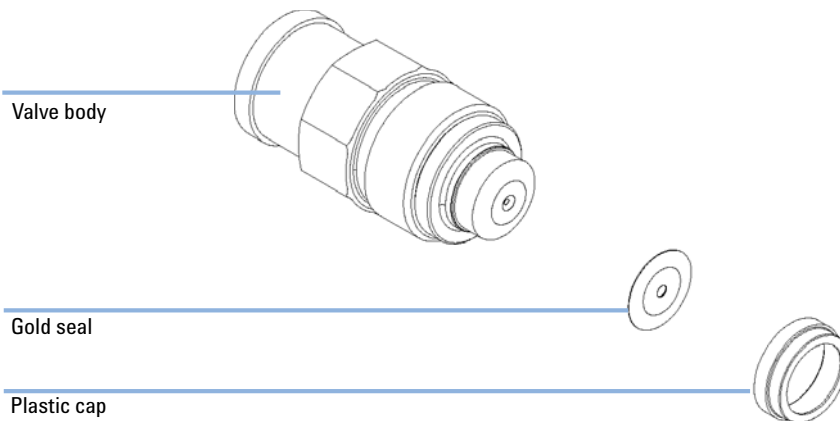

Figure 15 Outlet Ball Valve Parts

7 Maintenance

Simple Repairs

- 4 Reinstall the outlet ball valve and tighten the valve.
- 5 Reconnect the valve capillary.

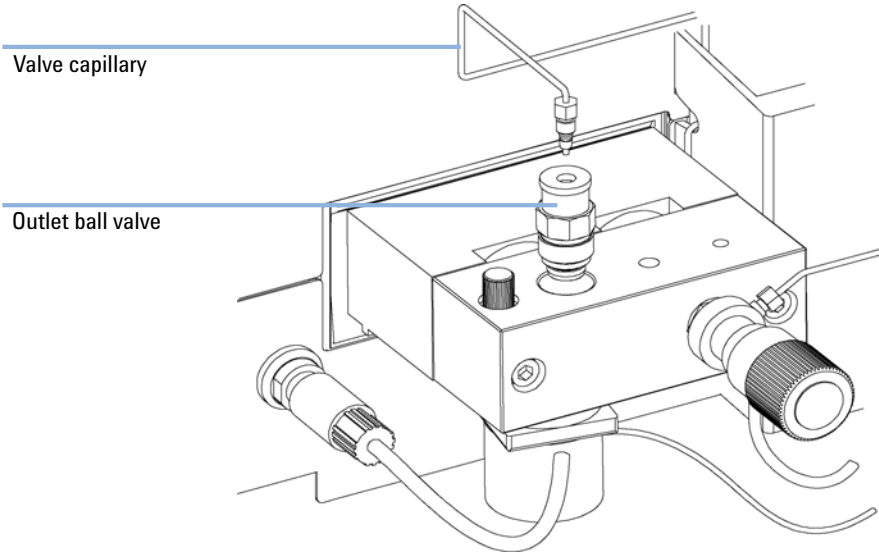

Figure 16 Exchanging the Outlet Ball Valve

Exchanging the Purge Valve Frit or the Purge Valve

When Frit – when plunger seals are exchanged or when contaminated or blocked (pressure drop of > 10 bar across the frit at a flow rate of 5 ml/min of H₂O with purge valve opened)
Purge valve – if internally leaking

Tools required

- Wrench 1/4 inch
- Wrench 14 mm
- Pair of tweezers or toothpick

Parts required

#	Part number	Description
5	01018-22707	PTFE frit (pack of 5)
1	G1311-60009	Purge valve

Preparations

- Switch off pump at the main power switch
- Remove the front cover

- 1** Using a 1/4 inch wrench disconnect the pump outlet capillary at the purge valve.
- 2** Disconnect the waste tube. Beware of leaking solvents due to hydrostatic pressure.
- 3** Using the 14 mm wrench unscrew the purge valve and remove it.
- 4** Remove the plastic cap with the gold seal from the purge valve.

7 Maintenance

Simple Repairs

- Using a pair of tweezers or a toothpick remove the frit.

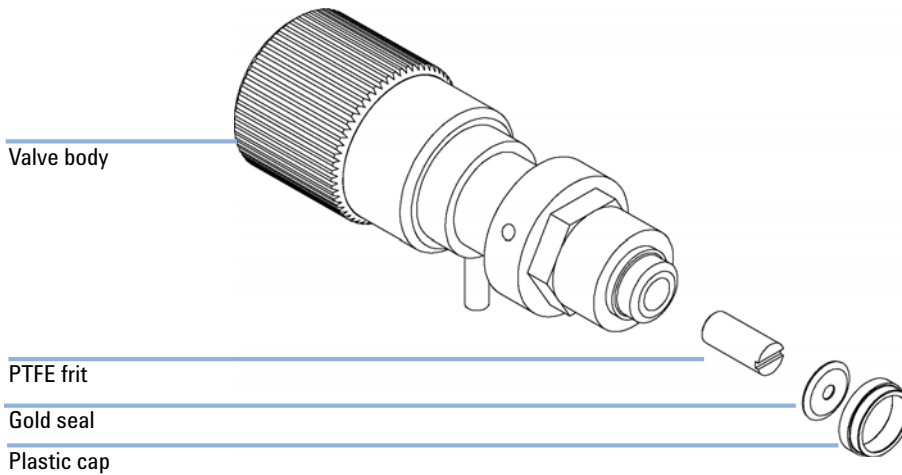

Figure 17 Purge Valve Parts

- Place a new frit into the purge valve with the orientation of the frit as shown above.
- Reinstall the cap with the gold seal.

NOTE

Before reinstallation always check the gold seal. A deformed seal should be exchanged.

- Insert the purge valve into the pump head and locate the pump outlet capillary and the waste tube as shown in [Figure 18](#) on page 87.

9 Tighten the purge valve and reconnect outlet capillary and waste tubing.

Purge valve

Outlet capillary

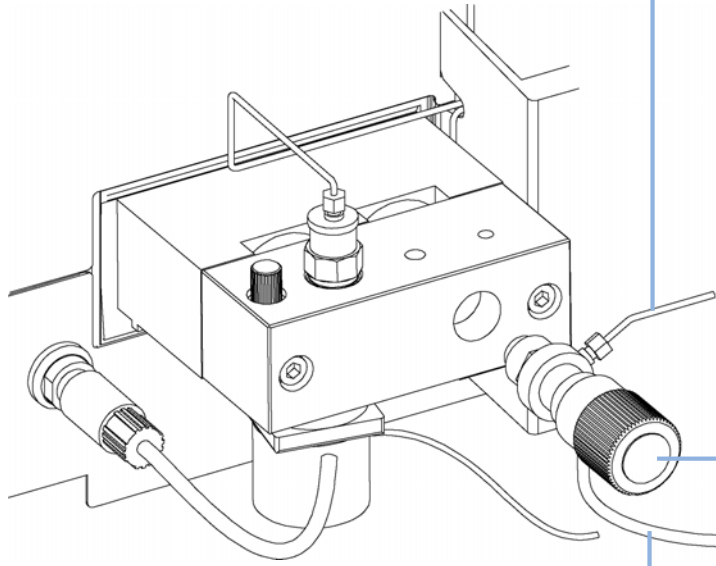

Waste tube

Figure 18 Exchanging the Purge Valve

Removing the Pump Head Assembly

- When**
- Exchanging the seals
 - Exchanging the plungers
 - Exchanging seals of the seal wash option

- Tools required**
- Wrench 1/4 inch
 - 4-mm hexagonal key

Preparations Switch off pump at the main power switch and unplug the power cable

CAUTION

Damage of the pump drive

Starting the pump when the pump head is removed may damage the pump drive.

→ Never start the pump when the pump head is removed.

- 1 Remove the front cover.
- 2 Disconnect the Active Inlet Valve cable.
- 3 Using a 1/4 inch wrench remove the outlet capillary.

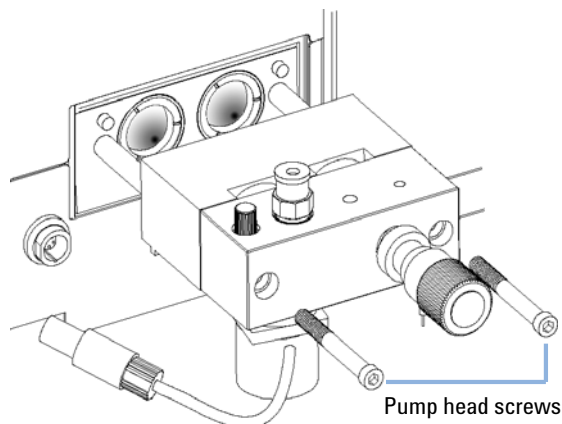

- 4 Disconnect the capillary from the Outlet Ball Valve.
- 5 Remove the waste tubing and disconnect the Active Inlet Valve tubing.
- 6 Remove the capillary at the bottom of the Pumphead.
- 7 Using a 4 mm hexagonal key, stepwise loosen the two Pumphead screws and remove the Pumphead from the Pump Drive.

Exchanging the Pump Seals and Seal Wear-in Procedure

When Seal leaking, if indicated by the results of the leak test.

Tools required

- Wrench 1/4 inch
- 4-mm hexagonal key

Parts required

#	Part number	Description
2	5063-6589	standard Seals (pack of 2) <i>or</i>
	0905-1420	Seals (pack of 2) for normal phase applications
1	0100-1847	For the seal wear-in procedure: Adapter AIV to inlet tube
1	5022-2159	Restriction capillary

Preparations

- Switch off pump at the main power switch
- Remove the front cover
- "Removing the Pump Head Assembly" on page 88

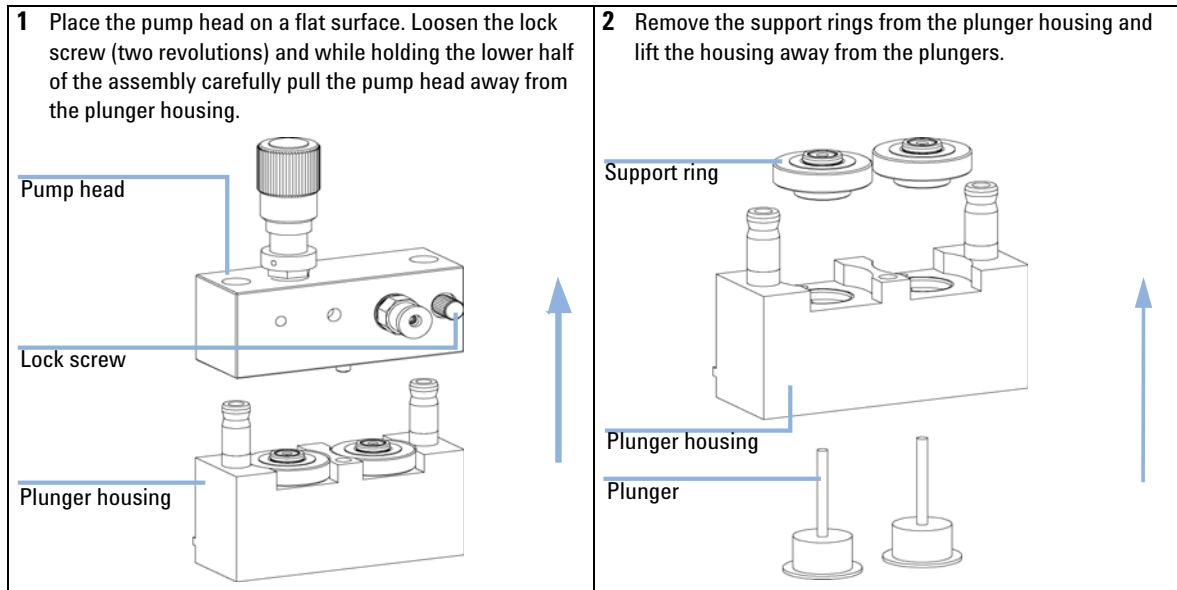

7 Maintenance

Simple Repairs

3 Using one of the plungers carefully remove the seal from the pump head (be careful not to break the plunger). Remove wear retainers, if still present.

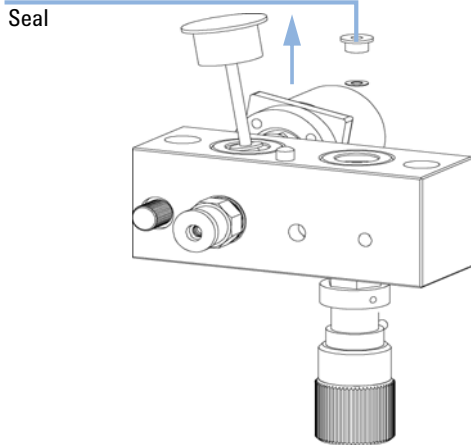

4 Insert new seals into the pump head.

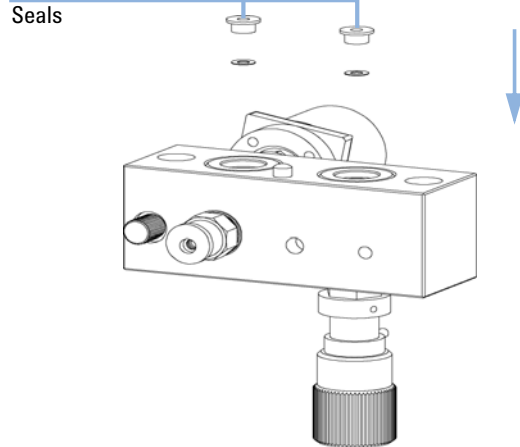

5 Reassemble the Pumphead assembly.

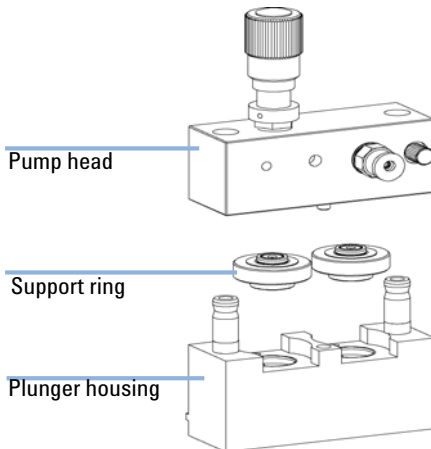

Seal Wear-in Procedure

NOTE

This procedure is required for standard seals only (5063-6589), but it will definitely damage the normal phase application seals (0905-1420).

- 1 Place a bottle with 100 ml of Isopropanol in the solvent cabinet and place a tubing (including bottle head assembly) in the bottle.
- 2 Screw the adapter (0100-1847) to the AIV and connect the inlet tube from the bottle head directly to it.
- 3 Connect the restriction capillary (5022-2159) to the purge valve. Insert its other end into a waste container.
- 4 Open the purge valve and purge the system for 5 minutes with isopropanol at a flow rate of 2 ml/min.
- 5 Close the purge valve, set the flow to a rate adequate to achieve a pressure of 350 bar. Pump 15 minutes at this pressure to wear in the seals. The pressure can be monitored at your analog output signal, with the handheld controller, Chemstation or any other controlling device connected to your pump.
- 6 Turn OFF the pump, slowly open the purge valve to release the pressure from the system, disconnect the restriction capillary and reinstall the bottle with the solvent for your application.
- 7 Rinse your system with the solvent used for your next application.

7 Maintenance

Simple Repairs

Exchanging the Plungers

When When scratched

Tools required

- Wrench 1/4 inch
- 4-mm hexagonal key

Parts required

#	Part number	Description
1	5063-6586	Plunger

Preparations

- Switch off pump at the main power switch
- Remove the front cover
- [“Removing the Pump Head Assembly”](#) on page 88

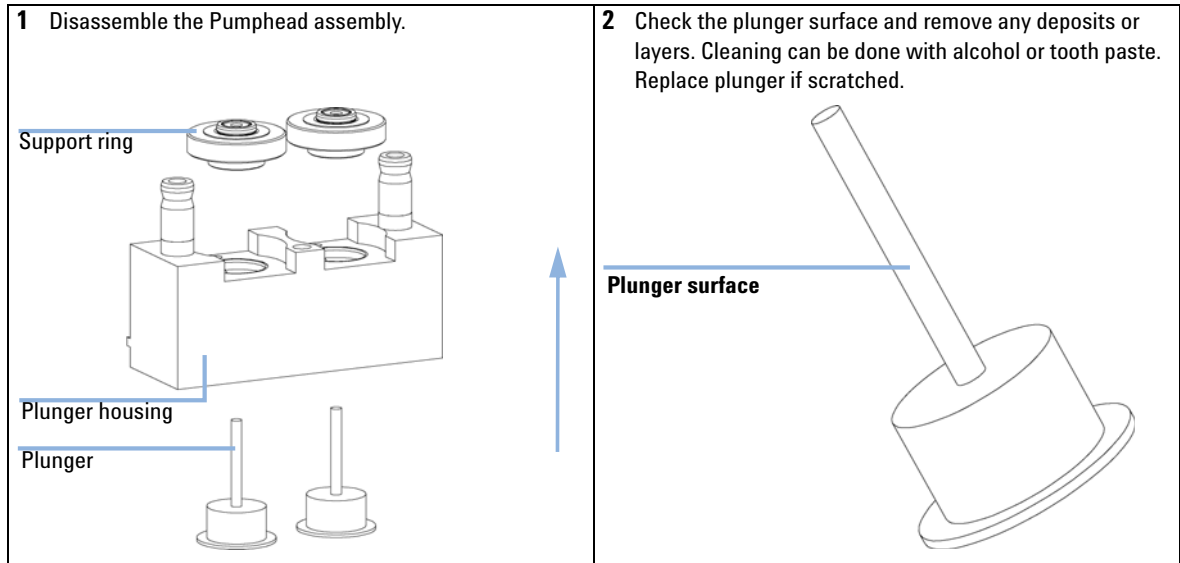

3 Reassemble the Pumphead assembly.

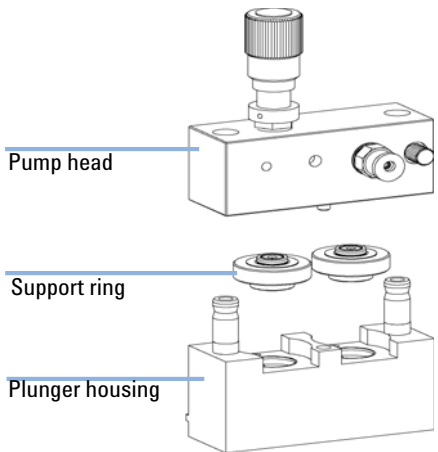

Installing the Seal Wash Option

When When installing seal wash option

Tools required

- 4-mm hexagonal key
- Screwdriver Pozidrive #1

Parts required

#	Part number	Description
1	G1311-68711	Active Seal Wash Option kit (Isocratic or Quaternary pump)
1	G1312-68711	Active Seal Wash Option kit (Binary pump)

Preparations

- Switch off the pump at the main power switch
- Remove the front cover
- Remove the top cover and foam

1 By using a screwdriver remove the metal plug in the z-panel.

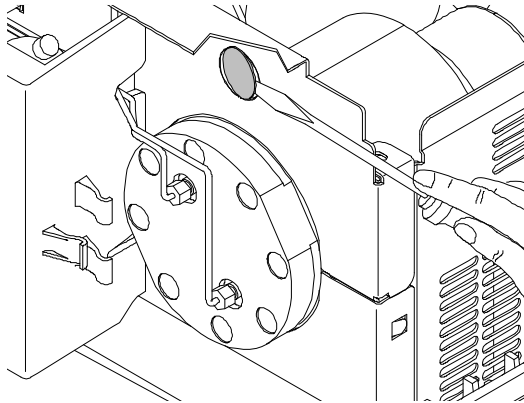

Figure 19 Removing the metal plug from the z-panel

- 2** Insert the socket, delivered with the Seal Wash pump assembly, into the hole on the z-panel.
- 3** Guide the wire of the active seal wash assembly through the hole and screw it onto the z-panel.
- 4** Guide the wire over the fan and plug the connector onto the mainboard connector P7.

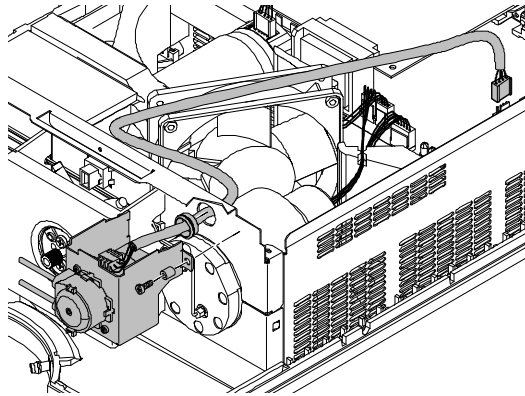

Figure 20 Wire connected to the mainboard.

- 5 Replace the foam and top cover.
- 6 Disconnect all capillaries and tubes from the pump head and disconnect the active inlet valve cable.
- 7 Using a 4-mm hexagonal key stepwise loosen and remove the two pump head screws and remove the pump head from the pump drive
- 8 Place the pump head, on the backside of the plungerhousing, on a flat surface. Loosen the lock screw (two revolutions) and while holding the lower half of the assembly carefully pull the pump head away from the plunger housing.
- 9 Remove the support rings from the plunger housing and lift the housing away from the plungers.
- 10 Install the support ring assembly from the active seal wash option kit into the plunger housing.

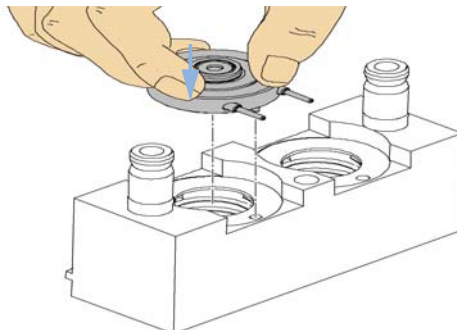

Figure 21 Inserting the active seal wash support rings.

7 Maintenance

Simple Repairs

- 11** Place the support rings on the plunger housing (plungers not installed) and snap the pump head and plunger housing together.
- 12** Insert the plungers and carefully press them into the seal.
- 13** Tighten the lock screw.
- 14** Slide the pump head assembly onto the metering drive. Apply a small amount of pump head grease (part number 79846-65501) to the pumphead screws and the balls of the spindle drive. Tighten the pumphead screws stepwise with increasing torque
- 15** Reconnect all capillaries, tubes and the active inlet valve cable to its connector.
- 16** Route the wash inlet tube into a bottle filled with a mixture of distilled water and isopropanol (90/10) and place the bottle above the pump in the solvent cabinet.
- 17** Route the outlet of the wash tube into a waste container.

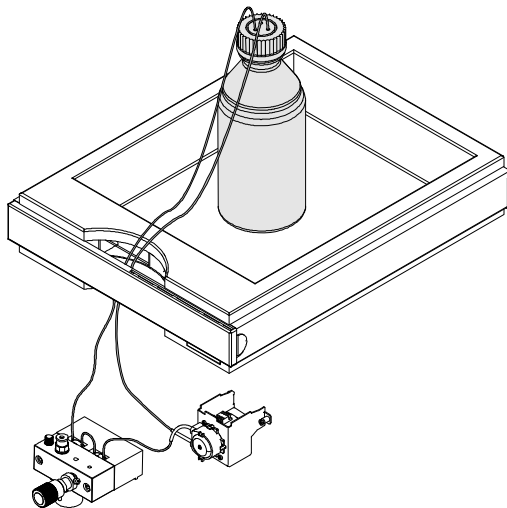

Figure 22 Pumphead after completed installation.

Exchanging the Wash Seals

When When maintaining seal wash option

Tools required • 4-mm hexagonal key

Parts required	#	Part number	Description
	1	0905-1175	Wash seal
	6	5062-2484	Gasket, seal wash (pack of 6)

Preparations

- Switch off pump at the main power switch
- Remove the front cover

1 Disconnect all capillaries and tubes from the pump head and disconnect the active inlet valve cable.

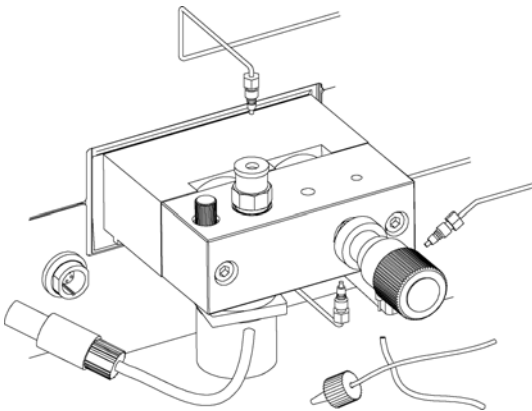

2 Using a 4-mm hexagonal key stepwise loosen and remove the two pump head screws and remove the pump head from the pump drive.

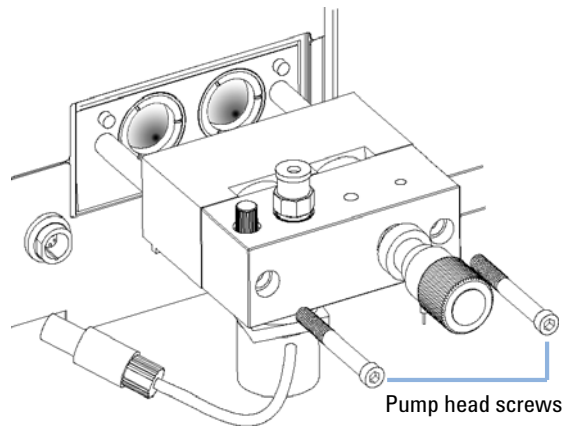

7 Maintenance

Simple Repairs

3 Remove the seal keeper and the seal wash support rings from the plunger housing. Remove the seal keeper from the support ring assembly.

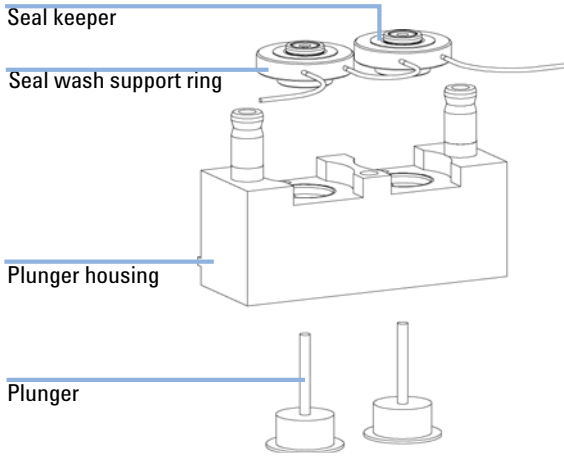

4 Using the blade of a flat-blade screwdriver remove the seal wash gasket and the secondary seal from the support ring.

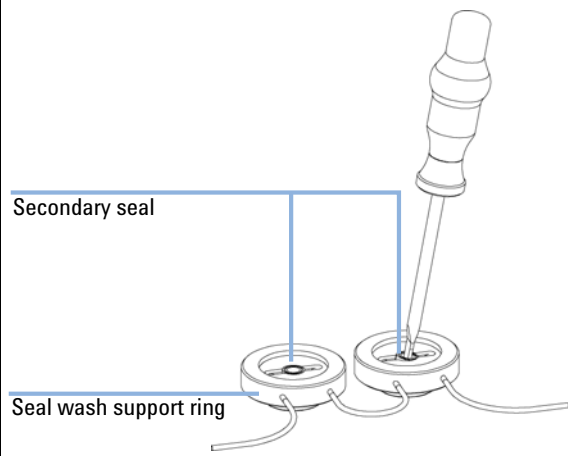

5 Using the insert tool press the secondary seal (spring pointing upwards) into the recess of the support ring. Place a seal wash gasket in the recess of the support ring.

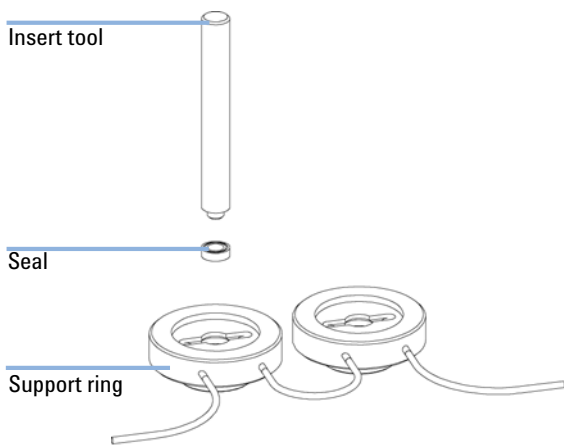

6 Place the support rings on the plunger housing (plungers not installed) and snap the pump head and plunger housing together.

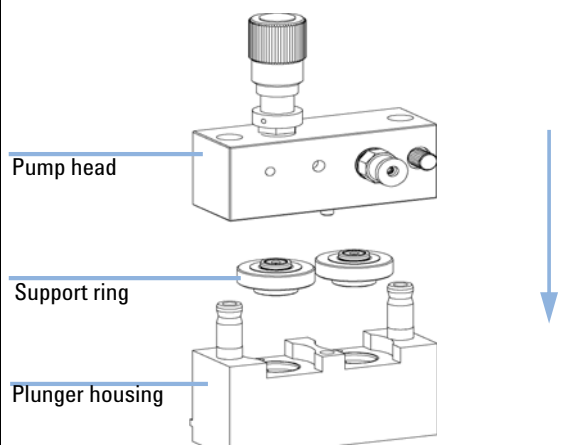

7 Insert the plungers and carefully press them into the seal.

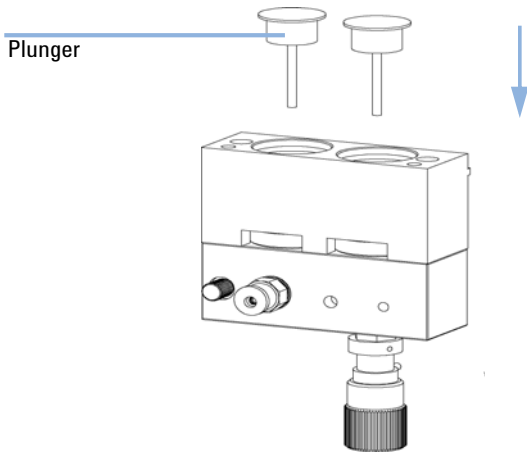

8 Tighten the lock screw.

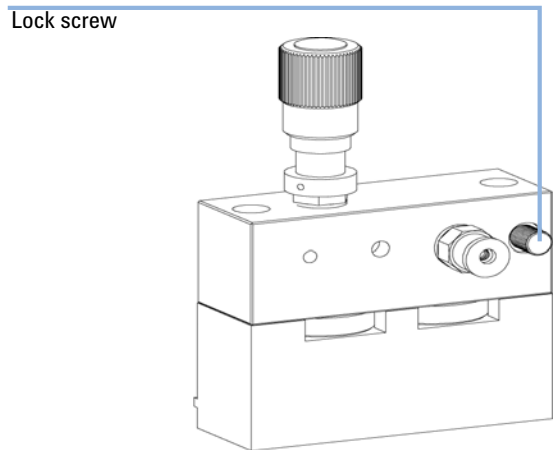

9 Slide the pump head assembly onto the metering drive. Apply a small amount of pump head grease to the pumphead screws and the balls of the spindle drive. Tighten the pumphead screws stepwise with increasing torque.

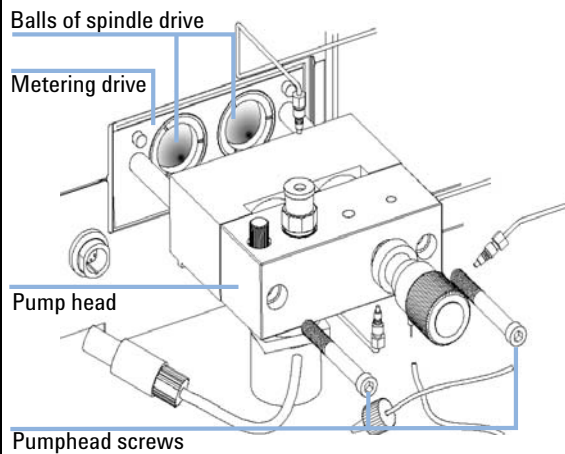

10 Reconnect all capillaries, tubes and the active inlet valve cable to its connector.

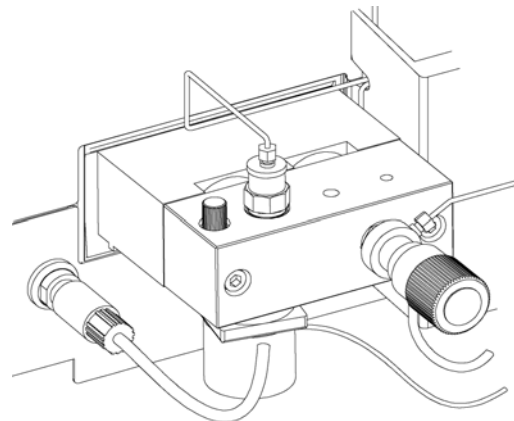

Reinstalling the Pump Head Assembly

When When reassembling the pump

Tools required • 4-mm hexagonal key

Parts required

#	Description
79846-65501	Pump head grease

- 1 Apply a small amount of grease on the back of the pistons.
- 2 Slide the Pumphead Assembly onto the Pumpdrive.
- 3 Using a 4 mm hexagonal key tighten the Pumphead screws stepwise with increasing torque.

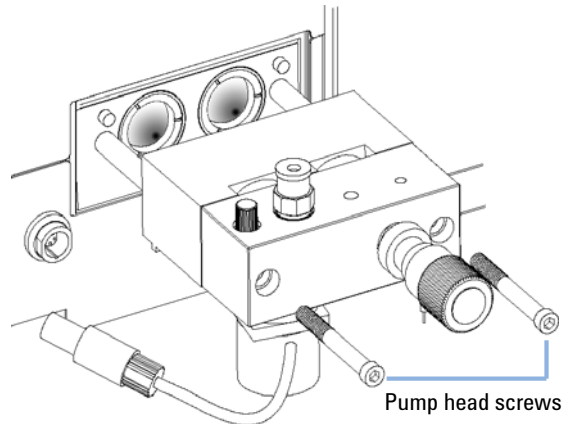

- 4 Reconnect the capillaries, tubing and the Active Inlet Valve cable to the connector.
- 5 Reinstall the front cover.

Exchanging the Multi-Channel Gradient Valve (MCGV)

Tools required • Pozidriv #1

Parts required	#	Part number	Description
	1	G1311-69701	MCGV (exchange assembly)

Preparations

- Switch the quaternary pump off at the power switch.
- Remove the front cover to have access to the pump mechanics.

NOTE

The lifetime of the multi-channel gradient valve can be maintained by regularly flushing the valve, especially when using buffer solutions. If using buffer solutions, flush all channels of the valve with water to prevent precipitation of the buffer. Salt crystals can be forced into an unused channel and form plugs that may lead to leaks of that channel. Such leaks will interfere with the general performance of the valve. When using buffer solutions and organic solvents in the Agilent 1200 Series Quaternary Pump it is recommended to connect the buffer solution to one of the bottom ports and the organic solvent to one of the upper gradient valve ports. It is best to have the organic channel directly above the salt solution channel (e.g., A - salt solution, B - organic solvent).

1 Disconnect the connecting tube, waste tube and the solvent tubes from the MCGV, unclip them from the tube clips and place them into the solvent cabinet to avoid flow by hydrostatic pressure.

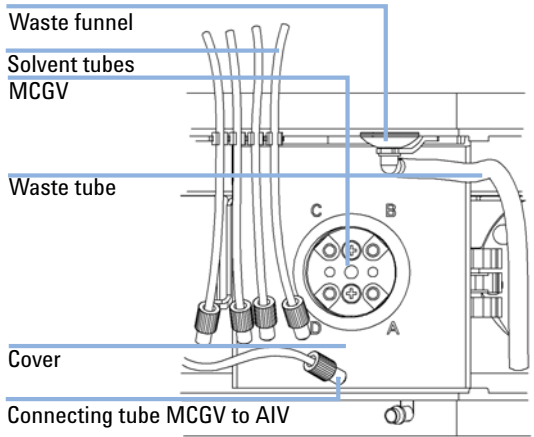

2 Press the lower sides of the cover to unclip it. Remove the cover.

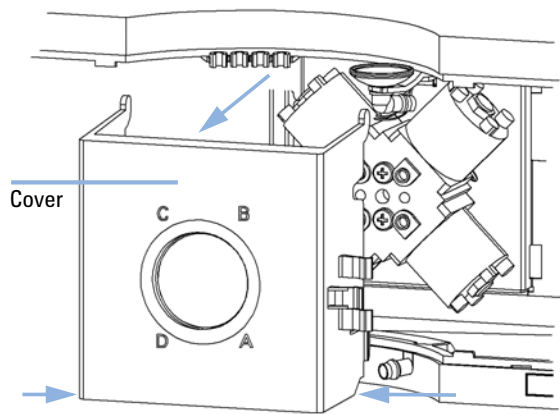

7 Maintenance

Simple Repairs

- 3** Disconnect the MCGV cable, unscrew the two holding screws and remove the valve.

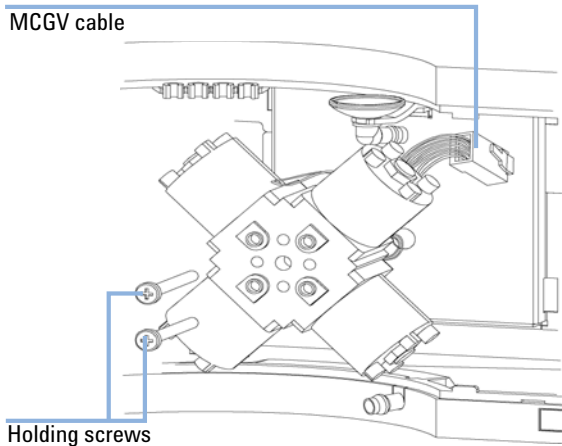

- 4** Place the new MCGV into position. Make sure that the valve is positioned with the A-channel at the bottom-right position. Tighten the two holding screws and connect the cable to its connector.

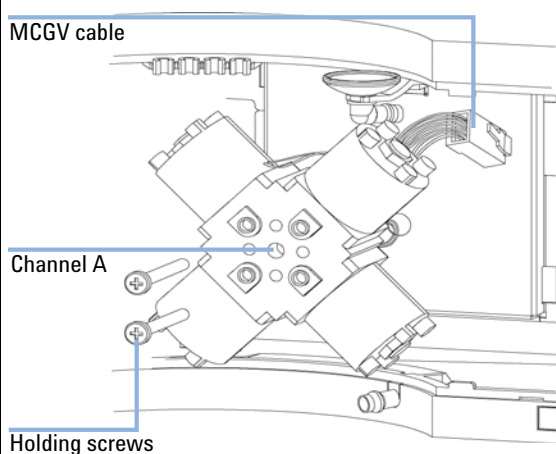

- 5** Replace the MCGV cover. Reconnect the waste funnel with the waste tube holder in the top cover. Insert waste tube in the holder in the waste pan and clip tube to the MCGV cover.

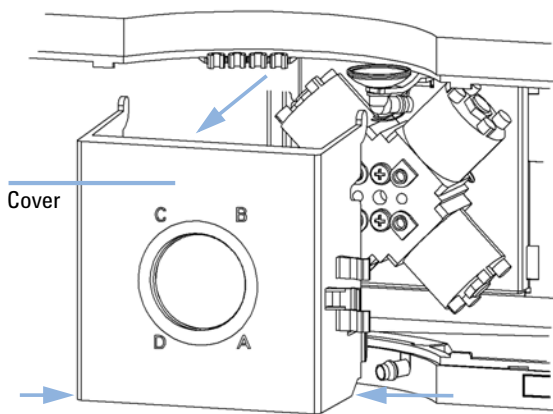

- 6** Reconnect the tube from the active inlet valve to the middle position of the MCGV and then the solvent tubes at channel A to D of the MCGV. Make sure the orientation of the channels on the cover is labelled as shown below, otherwise re-label the cover.

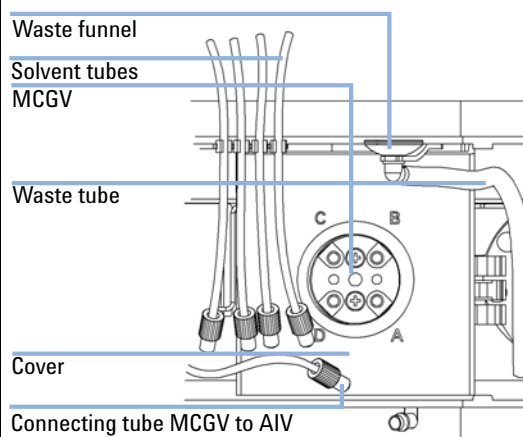

Exchanging the Optional Interface Board

When Board defective

Parts required	#	Part number	Description
	1	G1351-68701	

CAUTION

Electrostatic discharge at electronic boards and components

Electronic boards and components are sensitive to electrostatic discharge (ESD).

→ ? In order to prevent damage always use an ESD protection (for example, the ESD wrist strap from the accessory kit) when handling electronic boards and components.

- 1 Switch off the pump at the main power switch, unplug the pump from line power.
- 2 Disconnect cables from the interfaceboard connectors.
- 3 Loosen the screws. Slide out the interface board from the pump.
- 4 Install the new interface board. Secure screws.
- 5 Reconnect the cables to the board connector.
- 6 Reconnect the pump to line power.

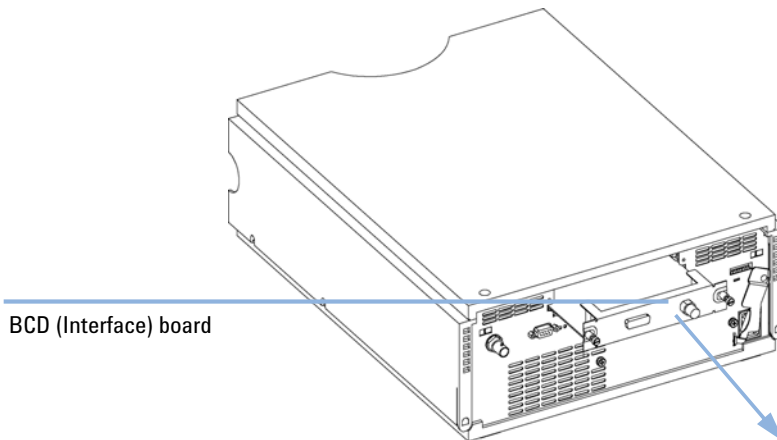

Figure 23 Exchanging the Interface Board

Replacing the Module's Firmware

When	<p>The installation of newer firmware might be necessary</p> <ul style="list-style-type: none">• if a newer version solves problems of older versions or• to keep all systems on the same (validated) revision. <p>The installation of older firmware might be necessary</p> <ul style="list-style-type: none">• to keep all systems on the same (validated) revision or• if a new module with newer firmware is added to a system or• if third part control software requires a special version.
Tools required	<ul style="list-style-type: none">• LAN/RS-232 Firmware Update Tool or• Agilent Lab Monitor & Diagnostic Software (LMD)• Instant Pilot G4208A (only if supported by module)• Control Module G1323B (only if supported by module)
Parts required	<p>Description</p> <p>Firmware, tools and documentation from Agilent web site</p>
Preparations	<p>Read update documentation provided with the Firmware Update Tool.</p> <p>To upgrade/downgrade the module's firmware the following steps have to be performed:</p> <ol style="list-style-type: none">1 Download the required module firmware, the latest LAN/RS-232 FW Update Tool and the documentation from the Agilent web.<ul style="list-style-type: none">• http://www.chem.agilent.com/scripts/cag_firmware.asp.2 Load the firmware into the module as described in the documentation.

NOTE Due to a different hardware platform, there is no way to convert a G1314D VWD and the G1314E VWD SL Plus to a G1314A/B VWD or G1314C VWD SL.



8 Parts and Materials for Maintenance

Overview of Main Assemblies	106
Pump Head Assembly	110
Pump Head Assembly with Seal Wash Option	112
Outlet Ball Valve Assembly	114
Purge Valve Assembly	115
Active Inlet Valve Assembly	116
Accessory Kit G1311-68705	117
Seal Wash Option Kit G1311-68711	118



Overview of Main Assemblies

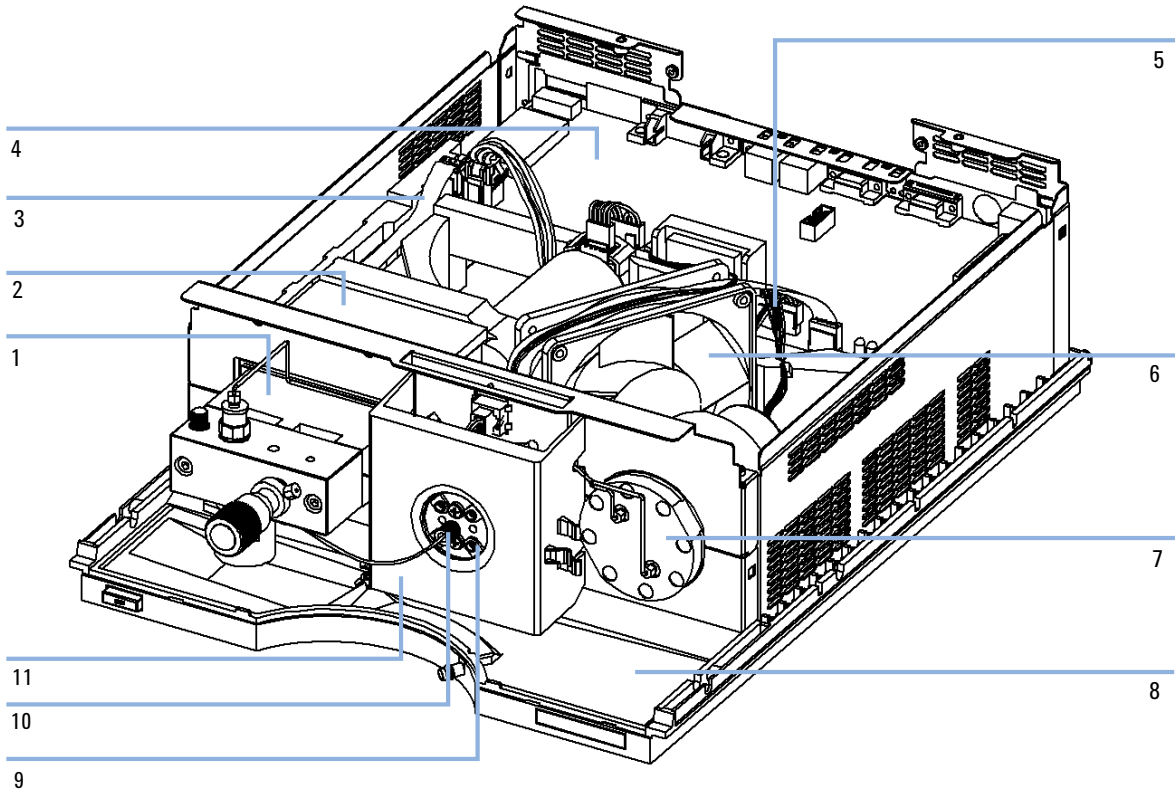

Figure 24 Overview of Main Assemblies (Front View)

Table 12 Repair Parts - Pump Housing and Main Assemblies (Front View)

Item	Description	Part Number
1	Pump head, see “ Pump Head Assembly ” on page 110	G1311-60004
2	Pump drive assembly Exchange assembly — pump drive	G1311-60001 G1311-69001
3	Cable assembly — AIV to main board	G1311-61601
4	Low-pressure pump main board (LPM) Exchange assembly — LPM board	G1311-66520 G1311-69520
5	Cable to MCGV	G1311-61600
6	Fan assembly	3160-1016
7	Damping unit	79835-60005
8	Leak pan — pump	5042-8590
9	Multi-gradient assembly (MCGV) Exchange assembly — MCGV	G1311-67701 G1311-69701
10	Screw, M4, 40 mm lg — MCGV	0515-0906
--	Rubber holder — MCGV	1520-0401
11	MCGV cover	G1311-44101

8 Parts and Materials for Maintenance

Overview of Main Assemblies

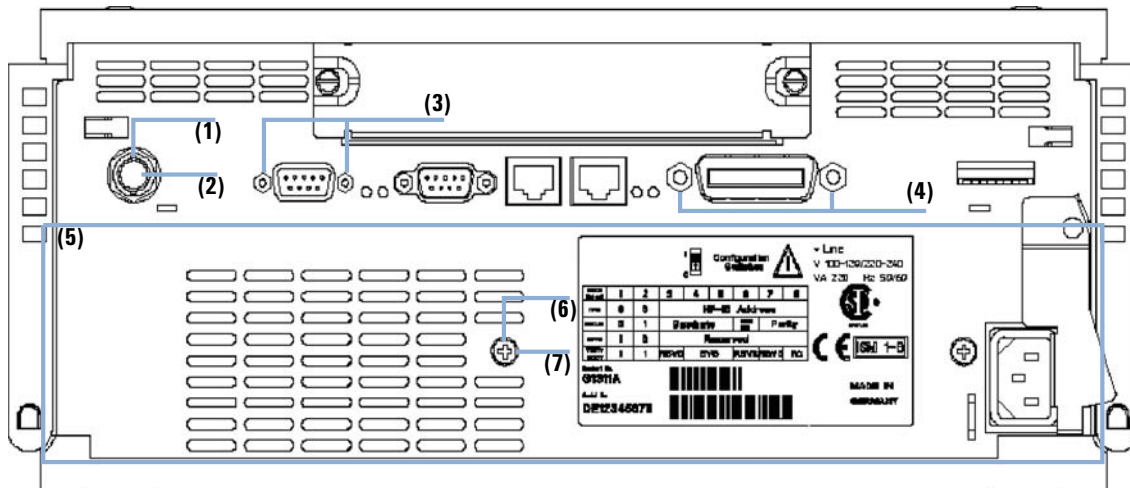

Figure 25 Overview of Main Assemblies (Rear View)

Table 13 Repair Parts - Pump Housing and Main Assemblies (Rear View)

Item	Description	Part Number
1	Nut M14 — analog output	2940-0256
2	Washer — analog output	2190-0699
3	Standoff — remote connector	1251-7788
4	Standoff — GPIB connector	0380-0643
5	Power supply (behind rear panel)	0950-2528
6	Screw, M4, 7 mm lg — power supply	0515-0910
7	Washer — power supply	2190-0409

Pump Head Assembly

Table 14 Pump Head Assembly

Item	Description	Part Number
	Complete assembly, including items marked with *	G1311-60004
1*	Sapphire plunger	5063-6586
2*	Plunger housing (including spring)	G1311-60002
3*	Support ring	5001-3739
4*	Seal (pack of 2) or Seal (pack of 2), for normal phase applications	5063-6589 0905-1420
5*	Pump chamber housing	G1311-25200
6	Active inlet valve body	G1312-60025
	Replacement cartridge for active inlet valve (400 bar)	5062-8562
7	Outlet ball valve	G1311-60012
8*	Screw lock	5042-1303
9	Purge valve assembly	G1311-60009
10	Screw M5, 60 mm lg	0515-2118

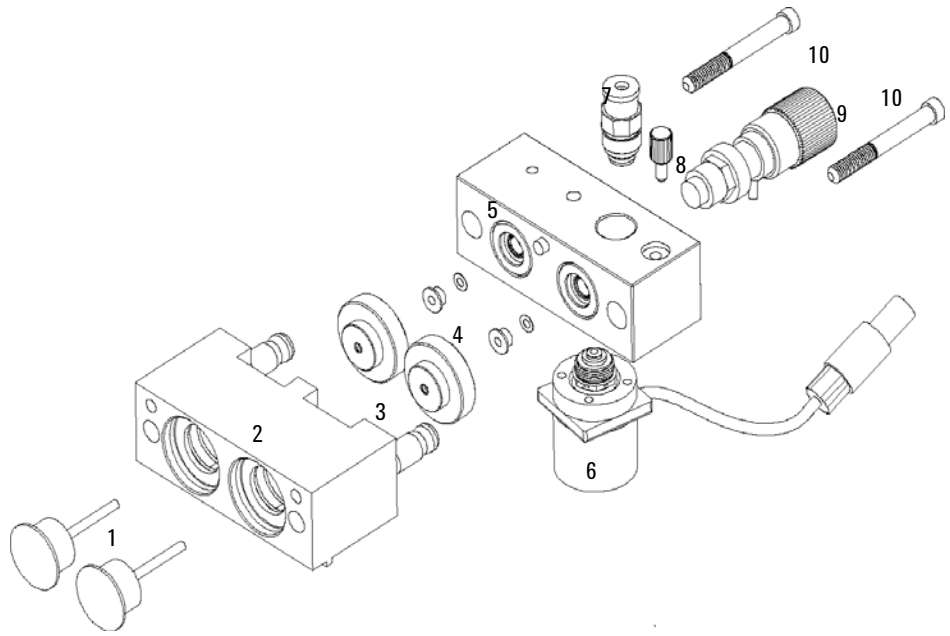

Figure 26 Pump Head Assembly

Pump Head Assembly with Seal Wash Option

Table 15 Pump Head Assembly with Seal Wash Option

Item	Description	Part Number
	Complete assembly, including parts marked with *	G1311-60005
1*	Sapphire plunger	5063-6586
2*	Plunger housing (including spring)	G1311-60002
3*	Support ring, seal wash	5062-2465
4*	Secondary seal	0905-1175
5*	Wash tube (1.0 m)	0890-1764
6*	Gasket, seal wash (pack of 6)	5062-2484
7*	Seal keeper	5001-3743
8*	Seal (pack of 2) or Seal (pack of 2), for normal phase applications	5063-6589 0905-1420
9*	Pump chamber housing	G1311-25200
10	Active inlet valve body	G1312-60025
	Replacement cartridge for active inlet valve (400 bar)	5062-8562
11	Outlet ball valve (complete with cartridge)	G1311-60012
12*	Screw lock	5042-1303
13	Purge valve	G1311-60009
14*	Screw M5, 60 mm lg	0515-2118
15*	Seal wash pump assembly	5065-9953
	Seal wash upgrade kit (see “ Seal Wash Option Kit G1311-68711 ” on page 118)	01018-68722

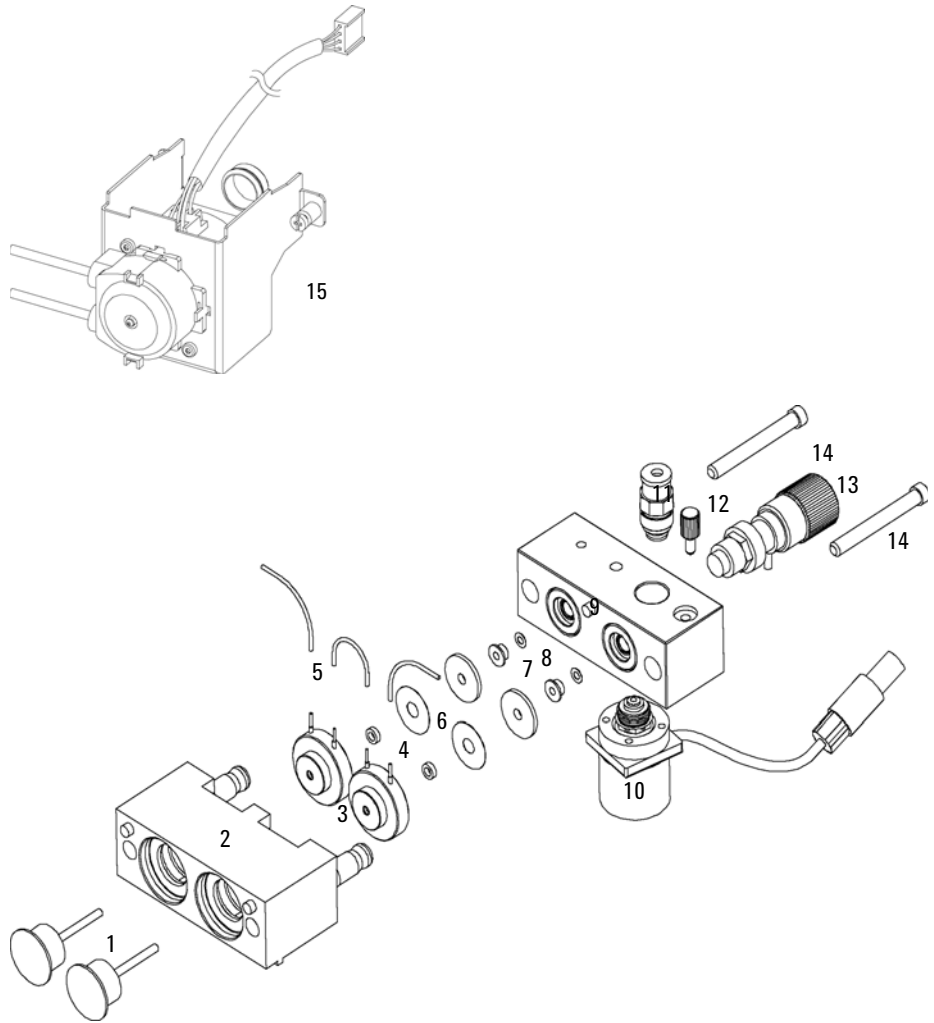

Figure 27 Pump Head with Seal Wash Option

Outlet Ball Valve Assembly

Table 16 Outlet Ball Valve Assembly

Item	Description	Part Number
	Outlet ball valve — complete assembly	G1311-60012
1	Socket cap	5042-1345
2	Outlet valve housing screw	01018-22410
3	Gold seal, outlet	5001-3707
4	Cap (pack of 4)	5062-2485

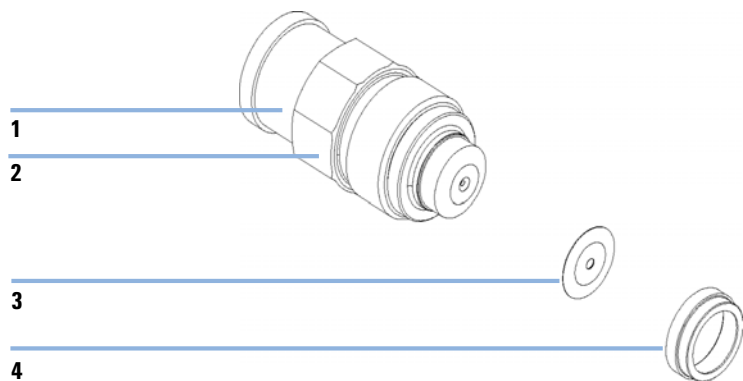

Figure 28 Outlet Ball Valve Assembly

Purge Valve Assembly

Table 17 Purge-Valve Assembly

Item	Description	Part Number
	Purge valve — complete assembly	G1311-60009
1	Valve body	No part number
2	PTFE frit (pack of 5)	01018-22707
3	Gold seal	5001-3707
4	Cap (pack of 4)	5062-2485

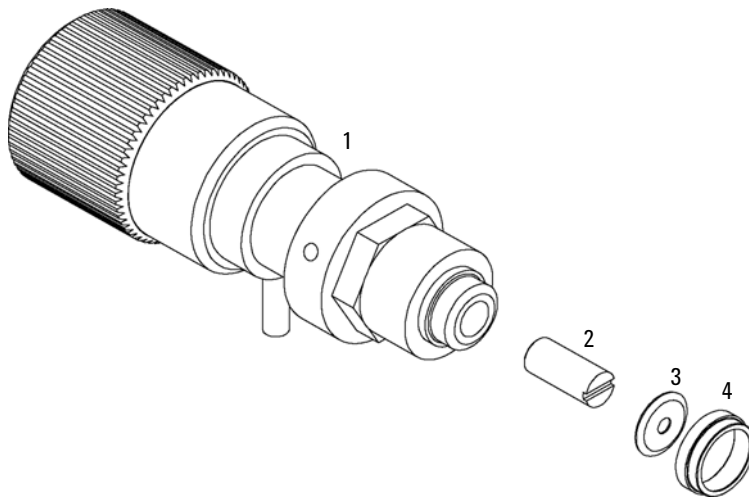

Figure 29 Purge-Valve Assembly

Active Inlet Valve Assembly

Table 18 Active Inlet Valve Assembly

Item	Description	Part Number
1	Active inlet valve body — No cartridge included	G1312-60025
2	Valve cartridge (400 bar)	5062-8562

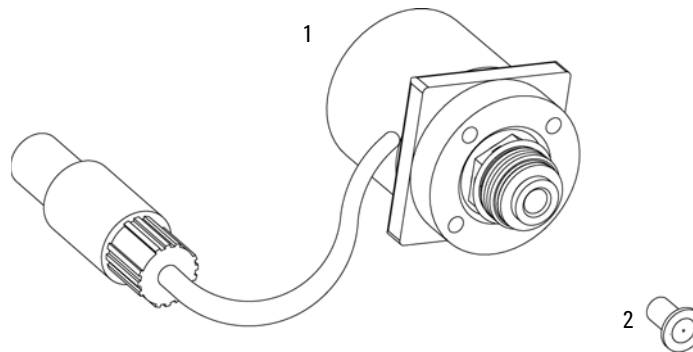

Figure 30 Active Inlet Valve Assembly

Accessory Kit G1311-68705

Table 19 Tools and Accessories

Description	Part Number
Wrench 14 mm	8710-1924
Seal insert tool	01018-23702
PTFE Frit (pack of 5)	01018-22707
Corrugated waste tube (1.2 m)	no PN
Corrugated waste tube (reorder number), 5 m	5062-2463
Velocity regulator (reorder number, pack of 3)	5062-2486
Hex key 4 mm	8710-2392
Wrench 1/4 – 5/16 inch	8710-0510
Capillary, pump to injection device, length 900 mm, ID 0.17 mm	G1329-87300

Seal Wash Option Kit G1311-68711

Table 20 Active Seal Wash Option kit for module

Description	Part Number
Seal wash pump assembly (includes pump cassette and pump motor)	5065-9953
Pump cassette (Silicone)	5042-8507
Support ring, seal wash (2 EA)	5062-2465
Secondary seal (pre-installed in support rings)	0905-1175
Gasket, wash seal (2 EA) (for re-order pack of 6)	5062-2484
Seal keeper (2 EA)	5001-3743
Silicone rubber tubing 1mm I.D. (3 m)	0890-1764
Seal (pack of 2)	5063-6589
Seals insert tool	01018-2370

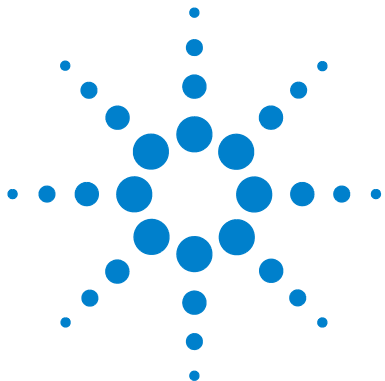

9 Identifying Cables

Cable Overview	120
Analog Cables	122
Remote Cables	125
BCD Cables	130
External Contact Cable	132
CAN/LAN Cables	133
Auxiliary Cable	134
RS-232 Cables	135



Cable Overview

NOTE

Never use cables other than the ones supplied by Agilent Technologies to ensure proper functionality and compliance with safety or EMC regulations.

Type	Description	Part Number
Analog cables	3390/2/3 integrators	01040-60101
	3394/6 integrators	35900-60750
	Agilent 35900A A/D converter	35900-60750
	General purpose (spade lugs)	01046-60105
Remote cables	3390 integrator	01046-60203
	3392/3 integrators	01046-60206
	3394 integrator	01046-60210
	3396A (Series I) integrator	03394-60600
	3396 Series II / 3395A integrator, see details in section "Remote Cables" on page 125	
	3396 Series III / 3395B integrator	03396-61010
	HP 1050 modules / HP 1046A FLD	5061-3378
	HP 1046A FLD	5061-3378
	Agilent 35900A A/D converter	5061-3378
	HP 1040 diode-array detector	01046-60202
BCD cables	HP 1090 liquid chromatographs	01046-60202
	Signal distribution module	01046-60202
	3396 integrator	03396-60560
Auxiliary	General purpose (spade Lugs)	G1351-81600
	Agilent 1100 Series vacuum degasser	G1322-61600

Type	Description	Part Number
<i>CAN cables</i>	Agilent 1100/1200 module to module, 0.5m lg	5181-1516
	Agilent 1100/1200 module to module, 1m lg	5181-1519
<i>External contacts</i>	Agilent 1100/1200 Series interface board to general purpose	G1103-61611
<i>GPIB cable</i>	Agilent 1100/1200 module to ChemStation, 1 m	10833A
	Agilent 1100/1200 module to ChemStation, 2 m	10833B
<i>RS-232 cable</i>	Agilent 1100/1200 module to a computer This kit contains a 9-pin female to 9-pin female Null Modem (printer) cable and one adapter.	34398A
<i>LAN cable</i>	Twisted pair cross over LAN cable, (shielded 3m long) (for point to point connection)	5023-0203
	Twisted pair cross over LAN cable, (shielded 7m long) (for point to point connection)	5023-0202

Analog Cables

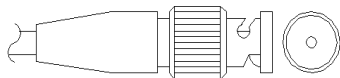

One end of these cables provides a BNC connector to be connected to Agilent 1100/1200 Series modules. The other end depends on the instrument to which connection is being made.

Agilent 1100/1200 to 3390/2/3 Integrators

Connector 01040-60101	Pin 3390/2/3	Pin Agilent 1100/1200	Signal Name
	1	Shield	Ground
	2		Not connected
	3	Center	Signal +
	4		Connected to pin 6
	5	Shield	Analog -
	6		Connected to pin 4
	7		Key
	8		Not connected

Agilent 1100/1200 to 3394/6 Integrators

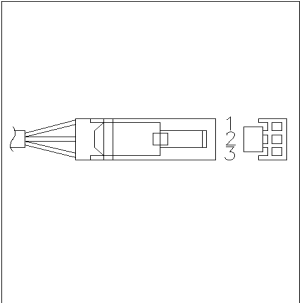
Connector 35900-60750	Pin 3394/6	Pin Agilent 1100/1200	Signal Name
	1		Not connected
	2	Shield	Analog -
	3	Center	Analog +

Agilent 1100/1200 to BNC Connector

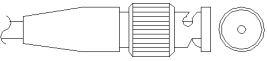
Connector 8120-1840	Pin BNC	Pin Agilent 1100/1200	Signal Name
	Shield	Shield	Analog -
	Center	Center	Analog +

9 Identifying Cables
Analog Cables

Agilent 1100/1200 to General Purpose

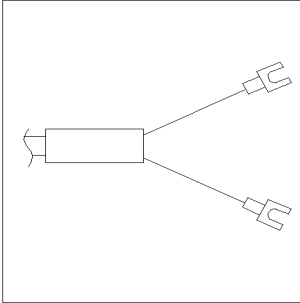
Connector 01046-60105	Pin 3394/6	Pin Agilent 1100/1200	Signal Name
	1		Not connected
	2	Black	Analog -
	3	Red	Analog +

Remote Cables



One end of these cables provides a Agilent Technologies APG (Analytical Products Group) remote connector to be connected to Agilent 1100/1200 Series modules. The other end depends on the instrument to be connected to.

Agilent 1100/1200 to 3390 Integrators

Connector 01046-60203	Pin 3390	Pin Agilent 1100/1200	Signal Name	Active (TTL)
<p>A diagram of a circular connector with 9 pins. The pins are arranged in a circle and numbered 1 through 9. Pin 1 is at the top, pin 2 is at the top-left, pin 3 is at the left, pin 4 is at the bottom-left, pin 5 is at the bottom, pin 6 is at the bottom-right, pin 7 is at the right, pin 8 is at the top-right, and pin 9 is at the top.</p>	2	1 - White	Digital ground	
	NC	2 - Brown	Prepare run	Low
	7	3 - Gray	Start	Low
	NC	4 - Blue	Shut down	Low
	NC	5 - Pink	Not connected	
	NC	6 - Yellow	Power on	High
	NC	7 - Red	Ready	High
	NC	8 - Green	Stop	Low
	NC	9 - Black	Start request	Low

Agilent 1100/1200 to 3392/3 Integrators

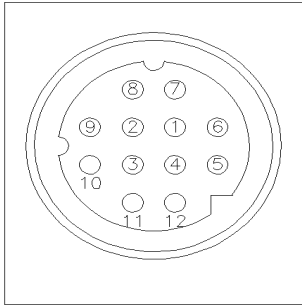
Connector 01046-60206	Pin 3392/3	Pin Agilent 1100/1200	Signal Name	Active (TTL)
	3	1 - White	Digital ground	
	NC	2 - Brown	Prepare run	Low
	11	3 - Gray	Start	Low
	NC	4 - Blue	Shut down	Low
	NC	5 - Pink	Not connected	
	NC	6 - Yellow	Power on	High
	9	7 - Red	Ready	High
	1	8 - Green	Stop	Low
	NC	9 - Black	Start request	Low

Agilent 1100/1200 to 3394 Integrators

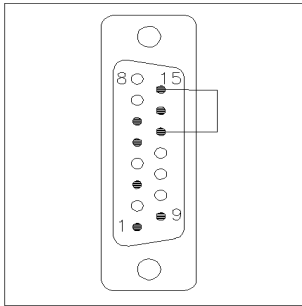
Connector 01046-60210	Pin 3394	Pin Agilent 1100/1200	Signal Name	Active (TTL)
	9	1 - White	Digital ground	
	NC	2 - Brown	Prepare run	Low
	3	3 - Gray	Start	Low
	NC	4 - Blue	Shut down	Low
	NC	5 - Pink	Not connected	
	NC	6 - Yellow	Power on	High
	5,14	7 - Red	Ready	High
	6	8 - Green	Stop	Low
	1	9 - Black	Start request	Low
	13, 15		Not connected	

NOTE

START and STOP are connected via diodes to pin 3 of the 3394 connector.

Agilent 1100/1200 to 3396A Integrators

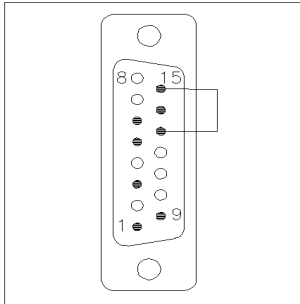
Connector 03394-60600	Pin 3394	Pin Agilent 1100/1200	Signal Name	Active (TTL)
	9	1 - White	Digital ground	
	NC	2 - Brown	Prepare run	Low
	3	3 - Gray	Start	Low
	NC	4 - Blue	Shut down	Low
	NC	5 - Pink	Not connected	
	NC	6 - Yellow	Power on	High
	5,14	7 - Red	Ready	High
	1	8 - Green	Stop	Low
	NC	9 - Black	Start request	Low
	13, 15		Not connected	

Agilent 1100/1200 to 3396 Series II / 3395A Integrators

Use the cable **part number: 03394-60600** and cut pin #5 on the integrator side. Otherwise the integrator prints START; not ready.

Agilent 1100/1200 to 3396 Series III / 3395B Integrators

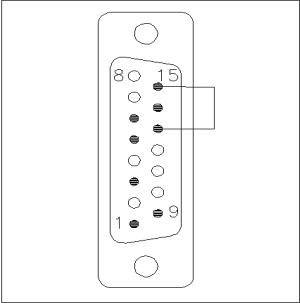
Connector 03396-61010	Pin 33XX	Pin Agilent 1100/1200	Signal Name	Active (TTL)
	9	1 - White	Digital ground	
	NC	2 - Brown	Prepare run	Low
	3	3 - Gray	Start	Low
	NC	4 - Blue	Shut down	Low
	NC	5 - Pink	Not connected	
	NC	6 - Yellow	Power on	High
	14	7 - Red	Ready	High
	4	8 - Green	Stop	Low
	NC	9 - Black	Start request	Low
	13, 15		Not connected	

Agilent 1100/1200 to HP 1050, HP 1046A or Agilent 35900 A/D Converters

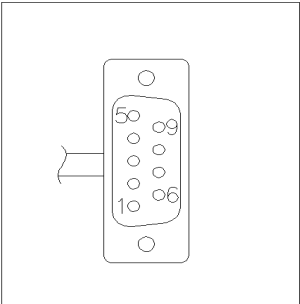
Connector 5061-3378	Pin HP 1050/....	Pin Agilent 1100/1200	Signal Name	Active (TTL)
	1 - White	1 - White	Digital ground	
	2 - Brown	2 - Brown	Prepare run	Low
	3 - Gray	3 - Gray	Start	Low
	4 - Blue	4 - Blue	Shut down	Low
	5 - Pink	5 - Pink	Not connected	
	6 - Yellow	6 - Yellow	Power on	High
	7 - Red	7 - Red	Ready	High
	8 - Green	8 - Green	Stop	Low
	9 - Black	9 - Black	Start request	Low

Agilent 1100/1200 to HP 1090 LC or Signal Distribution Module

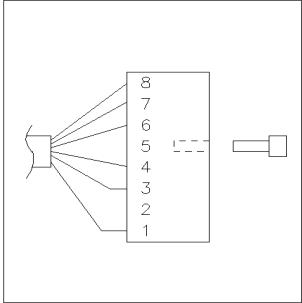
Connector01046-60202	Pin HP 1090	Pin Agilent 1100/1200	Signal Name	Active (TTL)
	1	1 - White	Digital ground	
	NC	2 - Brown	Prepare run	Low
	4	3 - Gray	Start	Low
	7	4 - Blue	Shut down	Low
	8	5 - Pink	Not connected	
	NC	6 - Yellow	Power on	High
	3	7 - Red	Ready	High
	6	8 - Green	Stop	Low
	NC	9 - Black	Start request	Low

Agilent 1100/1200 to General Purpose

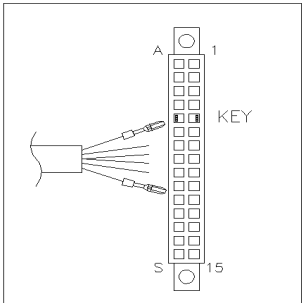
Connector01046-60201	Pin Universal	Pin Agilent 1100/1200	Signal Name	Active (TTL)
		1 - White	Digital ground	
		2 - Brown	Prepare run	Low
		3 - Gray	Start	Low
		4 - Blue	Shut down	Low
		5 - Pink	Not connected	
		6 - Yellow	Power on	High
		7 - Red	Ready	High
		8 - Green	Stop	Low
		9 - Black	Start request	Low

BCD Cables



One end of these cables provides a 15-pin BCD connector to be connected to the Agilent 1200 Series modules. The other end depends on the instrument to be connected to

Agilent 1200 to General Purpose

Connector G1351-81600	Wire Color	Pin Agilent 1200	Signal Name	BCD Digit
	Green	1	BCD 5	20
	Violet	2	BCD 7	80
	Blue	3	BCD 6	40
	Yellow	4	BCD 4	10
	Black	5	BCD 0	1
	Orange	6	BCD 3	8
	Red	7	BCD 2	4
	Brown	8	BCD 1	2
	Gray	9	Digital ground	Gray
	Gray/pink	10	BCD 11	800
	Red/blue	11	BCD 10	400
	White/green	12	BCD 9	200
	Brown/green	13	BCD 8	100
	not connected	14		
	not connected	15	+ 5 V	Low

Agilent 1200 to 3396 Integrators

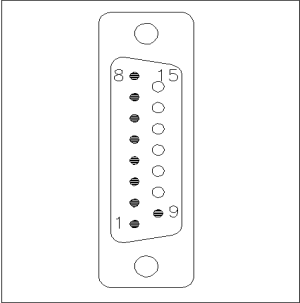
Connector 03396-60560	Pin 3392/3	Pin Agilent 1200	Signal Name	BCD Digit
	1	1	BCD 5	20
	2	2	BCD 7	80
	3	3	BCD 6	40
	4	4	BCD 4	10
	5	5	BCD0	1
	6	6	BCD 3	8
	7	7	BCD 2	4
	8	8	BCD 1	2
	9	9	Digital ground	
	NC	15	+ 5 V	Low

External Contact Cable

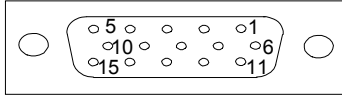

One end of this cable provides a 15-pin plug to be connected to Agilent 1200 Series module's interface board. The other end is for general purpose.

Agilent 1200 Series Interface Board to general purposes

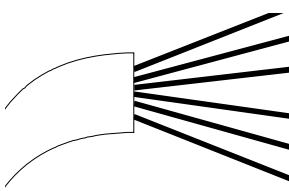
Connector G1103-61611	Color	Pin Agilent 1200	Signal Name
	White	1	EXT 1
	Brown	2	EXT 1
	Green	3	EXT 2
	Yellow	4	EXT 2
	Grey	5	EXT 3
	Pink	6	EXT 3
	Blue	7	EXT 4
	Red	8	EXT 4
	Black	9	Not connected
	Violet	10	Not connected
	Grey/pink	11	Not connected
	Red/blue	12	Not connected
	White/green	13	Not connected
	Brown/green	14	Not connected
	White/yellow	15	Not connected

CAN/LAN Cables

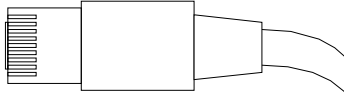

Both ends of this cable provide a modular plug to be connected to Agilent 1200 Series module's CAN or LAN connectors.

CAN Cables

Agilent 1200 module to module, 0.5 m	5181-1516
Agilent 1200 module to module, 1 m	5181-1519
Agilent 1200 module to control module	G1323-81600

LAN Cables

Description	Part number
Cross-over network cable (shielded, 3 m long), (for point to point connection)	5023-0203
Twisted pair network cable (shielded, 7 m long) (for hub connections)	5023-0202

Auxiliary Cable



One end of this cable provides a modular plug to be connected to the Agilent 1100 Series vacuum degasser. The other end is for general purpose.

Agilent 1100 Series Degasser to general purposes

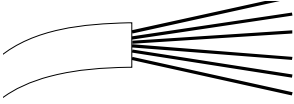
Connector G1322-81600	Color	Pin Agilent 1100	Signal Name
	White	1	Ground
	Brown	2	Pressure signal
	Green	3	
	Yellow	4	
	Grey	5	DC + 5 V IN
	Pink	6	Vent

RS-232 Cables

Description	Part number
RS-232 cable, instrument to PC, 9-to-9 pin (female) This cable has special pin-out, and is not compatible with connecting printers and plotters.	24542U G1530-60600
RS-232 cable kit, 9-to-9 pin (female) and one adapter 9-pin (male) 25-pin female. Suited for instrument to PC.	34398A
Cable Printer Serial & Parallel, is a SUB-D 9 pin female vs. Centronics connector on the other end (NOT FOR FW UPDATE).	5181-1529
This kit contains a 9-pin female to 9-pin female Null Modem (printer) cable and one adapter. Use the cable and adapter to connect Agilent Technologies instruments with 9-pin male RS-232 connectors to most PCs or printers.	34398A

9 Identifying Cables
RS-232 Cables



10 Appendix

General Safety Information [138](#)

The Waste Electrical and Electronic Equipment (WEEE) Directive
(2002/96/EC) [141](#)

Lithium Batteries Information [142](#)

Radio Interference [143](#)

Sound Emission [144](#)

Agilent Technologies on Internet [145](#)



General Safety Information

General Safety Information

The following general safety precautions must be observed during all phases of operation, service, and repair of this instrument. Failure to comply with these precautions or with specific warnings elsewhere in this manual violates safety standards of design, manufacture, and intended use of the instrument. Agilent Technologies assumes no liability for the customer's failure to comply with these requirements.

WARNING

Ensure the proper usage of the equipment.

The protection provided by the equipment may be impaired.

→ The operator of this instrument is advised to use the equipment in a manner as specified in this manual.

General

This is a Safety Class I instrument (provided with terminal for protective earthing) and has been manufactured and tested according to international safety standards.

Operation

Before applying power, comply with the installation section. Additionally the following must be observed.

Do not remove instrument covers when operating. Before the instrument is switched on, all protective earth terminals, extension cords, auto-transformers, and devices connected to it must be connected to a protective earth via a ground socket. Any interruption of the protective earth grounding will cause a potential shock hazard that could result in serious

personal injury. Whenever it is likely that the protection has been impaired, the instrument must be made inoperative and be secured against any intended operation.

Make sure that only fuses with the required rated current and of the specified type (normal blow, time delay, and so on) are used for replacement. The use of repaired fuses and the short-circuiting of fuse holders must be avoided.

Some adjustments described in the manual, are made with power supplied to the instrument, and protective covers removed. Energy available at many points may, if contacted, result in personal injury.

Any adjustment, maintenance, and repair of the opened instrument under voltage should be avoided whenever possible. When inevitable, this has to be carried out by a skilled person who is aware of the hazard involved. Do not attempt internal service or adjustment unless another person, capable of rendering first aid and resuscitation, is present. Do not replace components with power cable connected.

Do not operate the instrument in the presence of flammable gases or fumes. Operation of any electrical instrument in such an environment constitutes a definite safety hazard.





Do not install substitute parts or make any unauthorized modification to the instrument.

Capacitors inside the instrument may still be charged, even though the instrument has been disconnected from its source of supply. Dangerous voltages, capable of causing serious personal injury, are present in this instrument. Use extreme caution when handling, testing and adjusting.

When working with solvents please observe appropriate safety procedures (e.g. goggles, safety gloves and protective clothing) as described in the material handling and safety data sheet by the solvent vendor, especially when toxic or hazardous solvents are used.

Safety Symbols

Table 21 Safety Symbols

Symbol	Description
	The apparatus is marked with this symbol when the user should refer to the instruction manual in order to protect risk of harm to the operator and to protect the apparatus against damage.
	Indicates dangerous voltages.
	Indicates a protected ground terminal.
	Indicates eye damage may result from directly viewing the light produced by the deuterium lamp used in this product.
	The apparatus is marked with this symbol when hot surfaces are available and the user should not touch it when heated up.

WARNING

A WARNING

alerts you to situations that could cause physical injury or death.

- Do not proceed beyond a warning until you have fully understood and met the indicated conditions.

CAUTION

A CAUTION

alerts you to situations that could cause loss of data, or damage of equipment.

- Do not proceed beyond a caution until you have fully understood and met the indicated conditions.

The Waste Electrical and Electronic Equipment (WEEE) Directive (2002/96/EC)

Abstract

The Waste Electrical and Electronic Equipment (WEEE) Directive (2002/96/EC), adopted by EU Commission on 13 February 2003, is introducing producer responsibility on all Electric and Electronic appliances from 13 August 2005.



NOTE

This product complies with the WEEE Directive (2002/96/EC) marking requirements. The affixed label indicates that you must not discard this electrical/electronic product in domestic household waste.

Product Category: With reference to the equipment types in the WEEE Directive Annex I, this product is classed as a "Monitoring and Control instrumentation" product.

Do not dispose off in domestic household waste

To return unwanted products, contact your local Agilent office, or see www.agilent.com for more information.

Lithium Batteries Information

WARNING

Lithium batteries may not be disposed-off into the domestic waste. Transportation of discharged Lithium batteries through carriers regulated by IATA/ICAO, ADR, RID, IMDG is not allowed.

Danger of explosion if battery is incorrectly replaced.

- Discharged Lithium batteries shall be disposed off locally according to national waste disposal regulations for batteries.
- Replace only with the same or equivalent type recommended by the equipment manufacturer.



WARNING

Lithiumbatteri - Eksplosionsfare ved fejlagtig håndtering.

Udskiftning må kun ske med batteri af samme fabrikat og type.

- Lever det brugte batteri tilbage til leverandøren.

WARNING

Lithiumbatteri - Eksplosionsfare.

Ved udskiftning benyttes kun batteri som anbefalt av apparatfabrikanten.

- Brukt batteri returneres apparatleverandøren.

NOTE

Bij dit apparaat zijn batterijen geleverd. Wanneer deze leeg zijn, moet u ze niet weggooien maar inleveren als KCA.

Radio Interference

Cables supplied by Agilent Technologies are screened to provide optimized protection against radio interference. All cables are in compliance with safety or EMC regulations.

Test and Measurement

If test and measurement equipment is operated with unscreened cables, or used for measurements on open set-ups, the user has to assure that under operating conditions the radio interference limits are still met within the premises.

Sound Emission

Manufacturer's Declaration

This statement is provided to comply with the requirements of the German Sound Emission Directive of 18 January 1991.

This product has a sound pressure emission (at the operator position) < 70 dB.

- Sound Pressure $L_p < 70$ dB (A)
- At Operator Position
- Normal Operation
- According to ISO 7779:1988/EN 27779/1991 (Type Test)

Agilent Technologies on Internet

For the latest information on products and services visit our worldwide web site on the Internet at:

<http://www.agilent.com>

Select Products/Chemical Analysis

It will provide also the latest firmware of the Agilent 1200 Series modules for download.

Index

A

accessory kit, degasser 32
 accessory kit 31
 active inlet valve 79, 116
 active seal wash 8, 58, 94
 installing 94
 adapter 79, 82
 Agilent
 Diagnostic Software 64
 Lab Advisor Software 64
 on internet 145
 algae growth 52
 alternative seal material 59
 ambient operating temperature 25
 ambient non-operating temperature 25
 analog
 cable 120, 122
 AUTO mode 15
 AUX output 40
 auxiliary
 cable 120, 134

B

ball-screw drive 11
 battery
 safety information 142
 BCD board 17
 BCD
 cable 120, 130
 bench space 24
 bottle head assembly 30
 bottle 30
 buffer application 50

buffer solution 8, 101

C

cable
 analog 120, 122
 auxiliary 120, 134
 BCD 120, 130
 CAN 30, 133
 external contact 132
 external contacts 121
 GPIB 121
 interface 37
 LAN 121, 133
 power 30, 30
 remote 31, 120, 125
 RS-232 121, 135
 signal 31
 cables
 overview 120
 CAN
 cable 133
 capillary, pump to injection device 31
 changing solvents 45
 cleaning the pump 72
 composition precision 26
 composition range 26
 compressibility compensation 14, 26, 60
 condensation 24
 connecting tubes 32
 connections, flow 41
 control software 40, 40
 counter, seal wear 73
 counter, EMF 73

D

damaged packaging 30
 damaged parts 30
 degasser 30
 delay volume 13, 33
 delivery checklist 30
 Diagnostic
 software 64
 dimensions 25
 dual piston in-series design 9

E

early maintenance feedback (EMF) 16
 electrical connections
 descriptions of 18
 electrostatic discharge (ESD) 71, 103
 EMF limits 74
 EMF counters 73
 environment 22, 24
 error condition 67
 error messages 65
 ESD (electrostatic discharge) strap 72
 Exchanging the Active Inlet Valve Cartridge 81
 exchanging
 active inlet valve 77, 79
 internal parts 70
 multi channel gradient valve (MCGV) 101
 outlet ball valve 83
 outlet ball valve 77
 pistons 77, 92
 pump seals 77
 purge valve frit 85

Index

purge valve 85
purge valve frit 77
purge valve 77
wash seals 77, 94
external contact
cable 121, 132

F

features
GLP 27
instrument layout 16
safety and maintenance 27
firmware
updates 104
upgrade/downgrade 104
flow connections 41
flow precision 26, 26
flow range 26
frequency range 25

G

GPIB
cable 121
gradient formation 26
gradient valve 101

H

hex key set 31
hexagonal key, 4 mm 88, 89, 92, 97
hexagonal key, 4 mm 100
hints for successful use 50
humidity 25
hydraulic system 26

I

information
on sound emission 144
installation, pump module 36

instrument status
indicator 67
lamp 67
interface boards, optional 17
interface cables 37
internet 145
introduction to the pump 8

L

Lab Advisor
software 64
laboratory bench 24
lamp, power supply 66
lamp, status 66
lamp
instrument status 67
LAN
cable 121, 133
leak test 65
line frequency 25
line voltage 25
liter counters, counter, liter 73
lithium batteries 142
low-pressure pump main board (LPM) 17
low-pressure gradient 8

M

main power supply 17
main assemblies, overview 75
main assemblies 106
maintenance procedures 73
maintenance procedures 15
maintenance
replacing firmware 104
materials in contact with mobile
phase 13
missing parts 30

multi channel gradient valve (MCGV) 101

N

non-operating altitude 25
non-operating temperature 25
not-ready condition 67

O

operating Altitude 25
operating temperature 25
operational hints, vacuum degasser 56
operational pressure range 26
optional interface board 17
outlet ball valve 83
outlet ball valve 114
overview, pump 9

P

parts
active inlet valve 116
damaged 30
main assemblies 106
missing 30
outlet ball valve 114
pump head with seal wash 112
pump head 110
pump housing and main assemblies 107, 109
pH range 26
physical specifications 25
piston chamber 9
piston 50, 92
power supply indicator 66
power supply lamp 66
power consideration 22
power consumption 25
power switch 37

Index

prerun condition 67
pressure sensor readings 40
pressure pulsation 14, 26, 60
pressure range 59
pressure test 65
pressure, operating range 26
pressure 9
priming
 with a pump 47
 with a syringe 56
 with a pump 44
 with a syringe 44
 with the pump 56
proportioning valve, high-speed 9
PTFE frit 85
PTFE frit 31
pump head assembly 110
pump head with seal wash 112
pump piston 50
purge valve frit 50
purge valve 85
purging the pump 44

R

radio interference 143
reassembling the pump head 100
recommended pH range 26
remote
 cable 120, 125
removing
 pump head assembly 88
repairs 77
 replacing firmware 104
 using the ESD strap 72
RS-232
 cable 121
RS-232C
 cable 135
run mode 67

S

safety class I 138
safety information
 lithium batteries 142
safety
 general information 138, 138
 standards 25
 symbols 140
sapphire piston 11
seal insert tool 31
seal wash 8, 58
seal wear counters 73
seal wash 9
 installing 94
 when to use 58
seal, alternative material 59
seals 89, 92, 94, 94, 97, 100
seal
 wear-in 91
security lever 37, 70
setable flow range 26
shipping containers 30
simple repairs 77
simple repairs 70
site requirements 22
snap fasteners 41
solvent filters
 cleaning 78
solvent inlet filters 50
solvent tubes, degasser 30
solvent tubes 32
solvent bottle 30
solvent cabinet 50
solvent filters
 checking 78
 prevent blocking 52
solvent information 51
sonic bath 83

sound emission 144
specification
 physical 25
Stack Configuration
 Front View 33
 rear view 34
status indicator 65, 66
status lamp 66
stroke volume 11, 14
syringe adapter 32, 45
syringe 32

U

unpacking the pump 30

V

vacuum degasser 42, 50
vacuum degasser 8, 30
valve frit 85
variable reluctance motor 11
variable stroke volume 14
velocity regulator 31
voltage range 25

W

waste tube 32
waste tube 31
wear-in
 procedure 91
weight 25
wrench 1/4 inch 83, 85, 88, 88, 89,
89, 92, 92, 97, 97, 101, 101
wrench 1/4 inch 100, 100
wrench 14 mm 79, 81, 83, 85
wrench, 1/4 - 5/16 inch 31
wrench, 14 mm 31

Index

In This Book

This manual contains user information about Agilent 1200 Series Quaternary Pump. The manual describes the following:

- introduction,
- site requirements and specifications,
- installing the pump,
- using the quaternary pump,
- optimizing performance,
- troubleshooting and test functions,
- maintenance,
- parts and materials for maintenance,
- identifying cables,
- appendix.

© Agilent Technologies 2006-2007, 2008

Printed in Germany
11/08



G1311-90011



Agilent Technologies