

Agilent InfinityLab LC Series 1260 Infinity II Binary Pump



User Manual



Notices

© Agilent Technologies, Inc. 2016-2018

No part of this manual may be reproduced in any form or by any means (including electronic storage and retrieval or translation into a foreign language) without prior agreement and written consent from Agilent Technologies, Inc. as governed by United States and international copyright laws.

Manual Part Number

G7112-90000 Rev. B

Edition

08/2018

Printed in Germany

Agilent Technologies
Hewlett-Packard-Strasse 8
76337 Waldbronn

Warranty

The material contained in this document is provided “as is,” and is subject to being changed, without notice, in future editions. Further, to the maximum extent permitted by applicable law, Agilent disclaims all warranties, either express or implied, with regard to this manual and any information contained herein, including but not limited to the implied warranties of merchantability and fitness for a particular purpose. Agilent shall not be liable for errors or for incidental or consequential damages in connection with the furnishing, use, or performance of this document or of any information contained herein. Should Agilent and the user have a separate written agreement with warranty terms covering the material in this document that conflict with these terms, the warranty terms in the separate agreement shall control.

Technology Licenses

The hardware and/or software described in this document are furnished under a license and may be used or copied only in accordance with the terms of such license.

Restricted Rights Legend

If software is for use in the performance of a U.S. Government prime contract or subcontract, Software is delivered and licensed as “Commercial computer software” as defined in DFAR 252.227-7014 (June 1995), or as a “commercial item” as defined in FAR 2.101(a) or as “Restricted computer software” as defined in FAR 52.227-19 (June 1987) or any equivalent agency regulation or contract clause. Use, duplication or disclosure of Software is subject to Agilent Technologies’ standard commercial license terms, and non-DOD Departments and Agencies of the U.S. Government will

receive no greater than Restricted Rights as defined in FAR 52.227-19(c)(1-2) (June 1987). U.S. Government users will receive no greater than Limited Rights as defined in FAR 52.227-14 (June 1987) or DFAR 252.227-7015 (b)(2) (November 1995), as applicable in any technical data.

Safety Notices

CAUTION

A **CAUTION** notice denotes a hazard. It calls attention to an operating procedure, practice, or the like that, if not correctly performed or adhered to, could result in damage to the product or loss of important data. Do not proceed beyond a **CAUTION** notice until the indicated conditions are fully understood and met.

WARNING

A **WARNING** notice denotes a hazard. It calls attention to an operating procedure, practice, or the like that, if not correctly performed or adhered to, could result in personal injury or death. Do not proceed beyond a **WARNING** notice until the indicated conditions are fully understood and met.

In This Guide...

This manual covers the Agilent InfinityLab LC Series 1260 Infinity II Binary Pump (G7112B).

1 Introduction

This chapter gives an introduction to the module and an instrument overview.

2 Site Requirements and Specifications

This chapter provides information about site requirements and specifications for the binary pump.

3 Using the Pump

This chapter explains the operational parameters of the Binary Pump.

4 Optimizing Performance

This chapter gives information on how to optimize the performance of the Binary Pump under special operational conditions.

5 Troubleshooting and Diagnostics

Overview of the troubleshooting and diagnostic features.

6 Error Information

This chapter describes the meaning of error messages, and provides information on probable causes and suggested actions how to recover from error conditions.

7 Test Functions and Calibration

This chapter explains all test functions that are available for the binary pump.

8 Maintenance

This chapter describes the maintenance of the module.

In This Guide...

9 Parts and Materials for Maintenance

This chapter lists all parts and tools that are required for maintenance and simple repairs.

10 Identifying Cables

This chapter provides information on cables used with the Agilent InfinityLab LC Series modules.

11 Hardware Information

This chapter provides detailed technical information about your binary pump.

12 LAN Configuration

This chapter provides information on connecting the module to the Agilent ChemStation PC.

13 Appendix

This chapter provides additional information on safety, legal and web.

Contents

1	Introduction	9
	Instrument and Operation	10
	Overview of the Hydraulic Path	15
	Leak and Waste Handling	20
2	Site Requirements and Specifications	25
	Site Requirements	26
	Physical Specifications	29
	Performance Specifications	30
3	Using the Pump	33
	Magnets	34
	Turn on/off	35
	Status Indicators	37
	Best Practices	38
	Leak and Waste Handling	40
	Hints for Successful Use of the Binary Pump	41
	Setting up the Pump with the G4208A Instant Pilot	42
	Setting up the Pump with the Instrument Control Interface	43
	Solvent Information	48
	Algae Growth in HPLC Systems	54
	Prevent Blocking of Solvent Filters	55
	Normal Phase Applications	57
4	Optimizing Performance	59
	When to Use a Vacuum Degasser	60
	When to Use the Active Seal Wash Option	61
	When to Use the Low Volume Mixer	62
	When to Remove Damper and Mixer	63
	How to Optimize the Compressibility Compensation Setting	66

5	Troubleshooting and Diagnostics	69
	Overview of the Module's Indicators and Test Functions	70
	User Interfaces	72
	Agilent Lab Advisor Software	73
6	Error Information	75
	What Are Error Messages	77
	General Error Messages	78
	Module Error Messages	84
7	Test Functions and Calibration	95
	(System) Pressure Test	96
	Valve Test	101
	Binary Pump Solvent Compressibility Calibration	103
	Pump Elasticity Calibration	105
	Pump Leak Rate Test	107
8	Maintenance	111
	Introduction to Maintenance	112
	Cautions and Warnings	113
	Cleaning the Module	115
	Overview of Maintenance and Simple Repairs	116
	Maintenance Procedures	117
	Remove and Install Doors	118
	Exchange the Purge Valve Frit or the Purge Valve	120
	Replace the O-Ring on the Purge Valve	123
	Remove the Pump Head Assembly	125
	Maintenance of a Pump Head without Seal Wash	127
	Maintenance of a Pump Head with Seal Wash	130
	Reinstall the Pump Head Assembly	134
	Seal Wear-in Procedure	136
	Exchange the Active Inlet Valve (AIV) or its Cartridge	137
	Exchange the Seal Wash Cartridge	140
	Replace Leak Handling System Parts	142
	Exchange the Outlet Valve	144
	Installation of the Solvent Selection Valve Upgrade Kit	146
	Exchange the Solvent Selection Valve	148
	Replacing Module Firmware	151

9	Parts and Materials for Maintenance	153
	Hydraulic Path with Solvent Selection Valve	154
	Hydraulic Path without Solvent Selection Valve	156
	Pump Head Assembly Without Seal Wash	158
	Pump Head Assembly with Seal Wash Option	160
	Outlet Valve	162
	Purge Valve Assembly	163
	Active Inlet Valve Assembly	164
	HPLC System Tool Kit	165
	Active Seal Wash Option	166
	Solvent Cabinet	167
	Bottle Head Assembly	168
	Cover Parts	169
	Accessory Kit	170
10	Identifying Cables	171
	Cable Overview	172
	Analog Cables	174
	Remote Cables	176
	CAN/LAN Cables	180
	RS-232 Cable Kit	181
	Agilent 1200 Module to Printer	182
11	Hardware Information	183
	Firmware Description	184
	Electrical Connections	187
	Interfaces	189
	Setting the 6-bit Configuration Switch	197
	Early Maintenance Feedback	201
	Instrument Layout	202
12	LAN Configuration	203
	What You Have to Do First	204
	TCP/IP parameter configuration	205
	Configuration Switches	206
	Initialization Mode Selection	207
	Dynamic Host Configuration Protocol (DHCP)	209
	Manual Configuration	212

Contents

13 Appendix 217

General Safety Information 218

Waste Electrical and Electronic Equipment (WEE) Directive 224

Radio Interference 225

Sound Emission 226

Agilent Technologies on the Internet 227

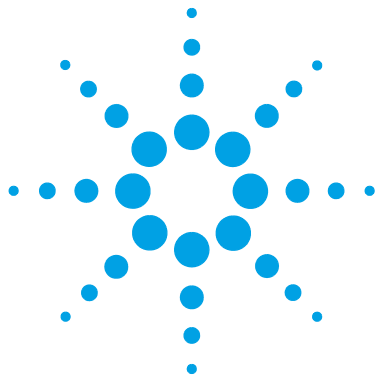

1 Introduction

Instrument and Operation	10
Introduction to the Pump	10
Principle of Operation	11
Product Description	14
Features	14
Overview of the Hydraulic Path	15
Leak and Waste Handling	20
Leak Sensor	23
Waste Concept	24

This chapter gives an introduction to the module and an instrument overview.



Instrument and Operation

Introduction to the Pump

The binary pump comprises two identical pumps integrated into one housing. Binary gradients are created by high-pressure mixing. A built-in degasser is available for applications that require best flow stability, especially at low flow rates, for maximum detector sensitivity. Pulse damper and mixer can be bypassed for low flowrate applications or whenever a minimal transient volume is desirable. Typical applications are high throughput methods with fast gradients on high resolution 2.1 mm columns. The pump is capable of delivering flow in the range of 0.1 – 5 mL/min against up to 600 bar. A solvent selection valve (optional) allows to form binary mixtures (isocratic or gradient) from one of two solvents per channel. Active seal wash (optional) is available for use with concentrated buffer solutions.

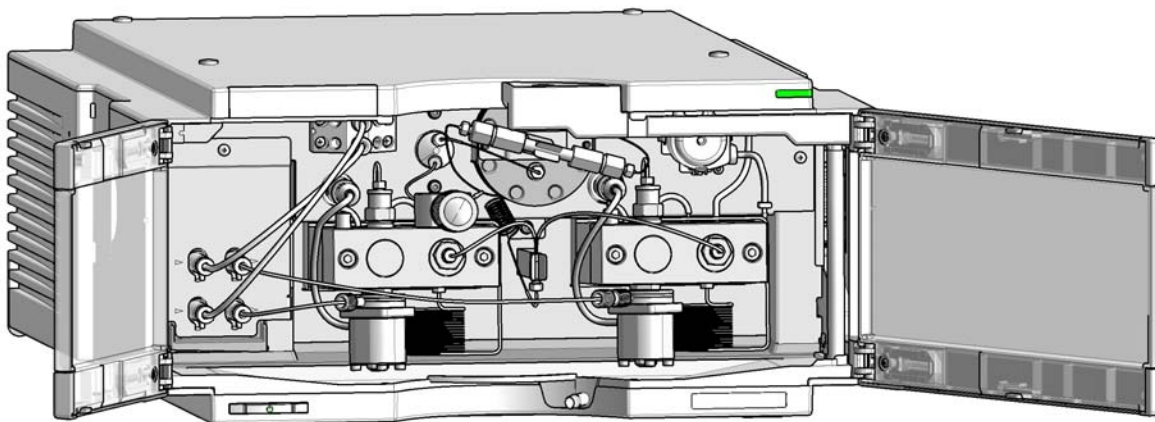

Figure 1 Overview of the binary pump

Principle of Operation

The binary pump is based on a two-channel, dual-piston in-series design which comprises all essential functions that a solvent delivery system has to fulfill. Metering of solvent and delivery to the high-pressure side are performed by two pump assemblies which can generate pressure up to 600 bar.

Each channel comprises a pump assembly including pump drive, pump head, active inlet valve with replaceable cartridge, and outlet valve. The two channels are fed into a low-volume mixing chamber which is connected via a restriction capillary coil to a damping unit and a mixer. A pressure sensor monitors the pump pressure. A purge valve with integrated PTFE frit is fitted to the pump outlet for convenient priming of the pumping system.

1 Introduction

Instrument and Operation

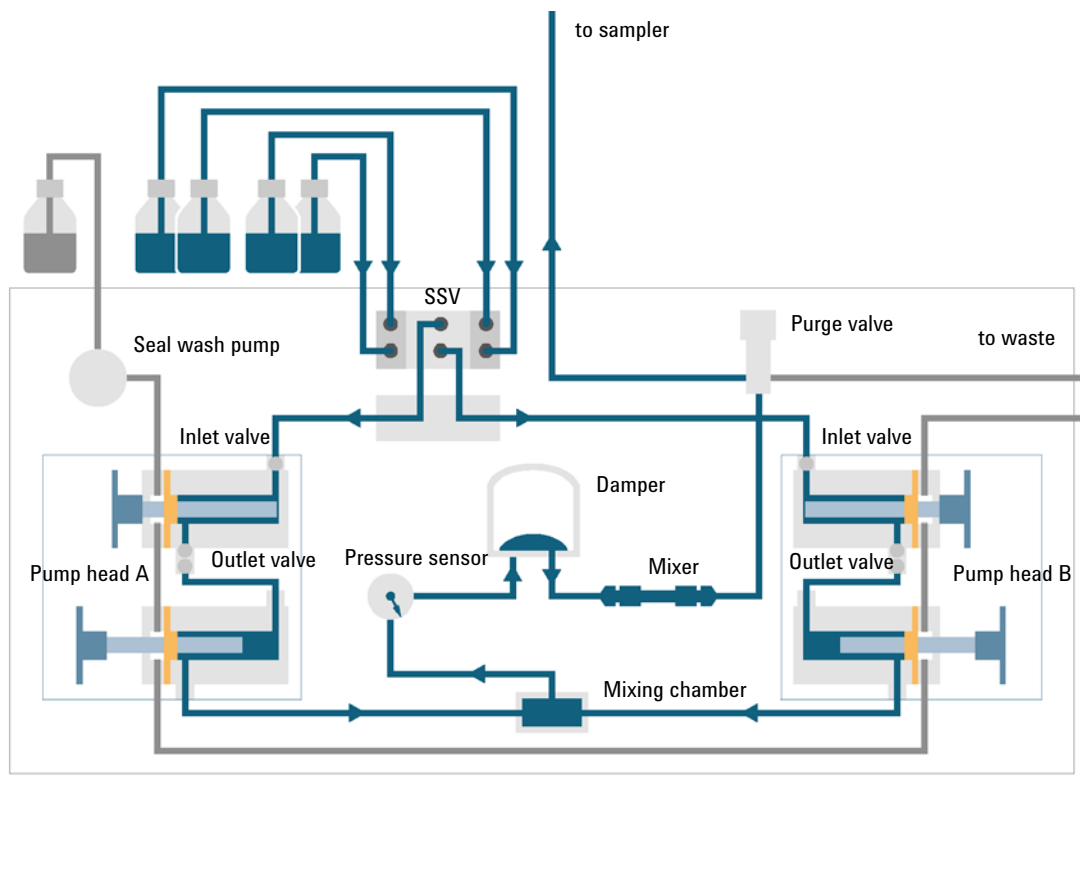

Figure 2 The hydraulic path of the Binary Pump with damper and mixer

Damper and mixer can be bypassed for lowest delay volume of the binary pump. This configuration is recommended for low flow rate applications with steep gradients.

Figure 3 on page 13 illustrates the flow path in low delay volume mode. For instructions on how to change between the two configurations, see “[Convert the Binary Pump to Low Delay Volume Mode](#)” on page 64.

NOTE

Bypassing the mixer while the damper remains in line is not a supported configuration and may lead to undesired behavior of the binary pump.

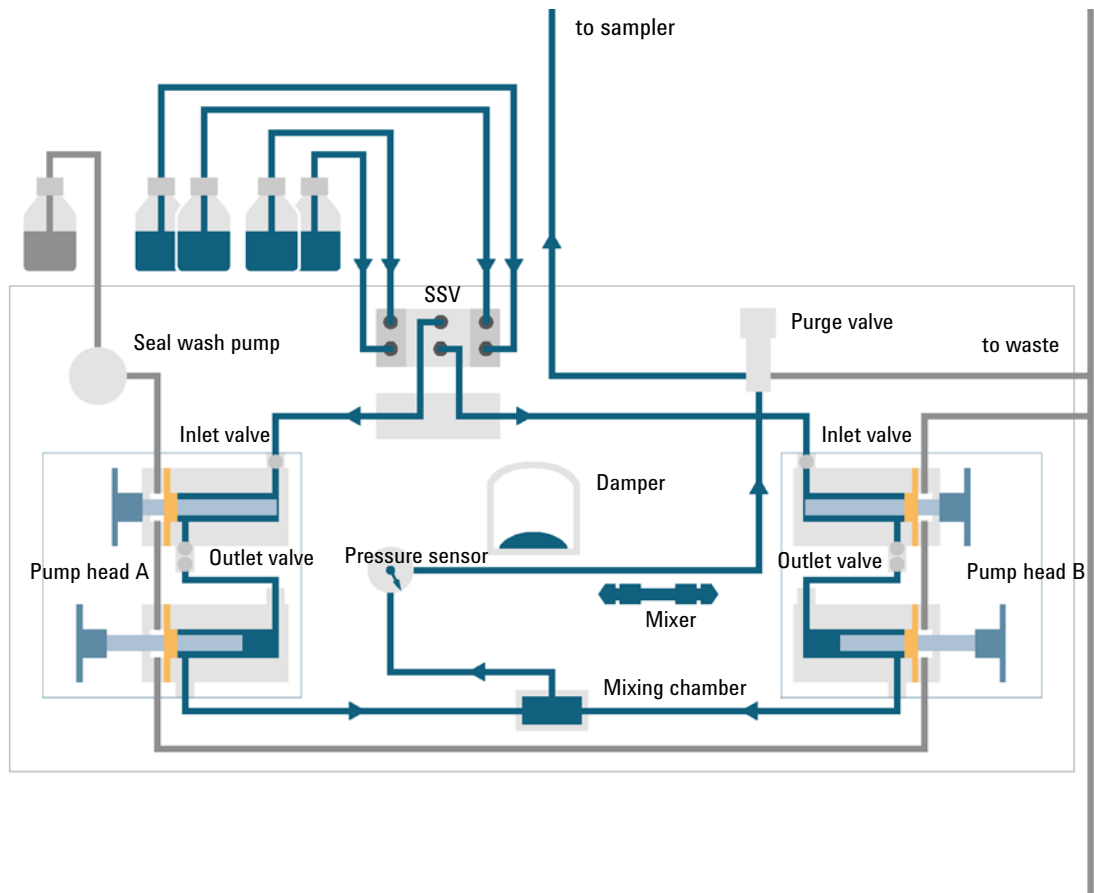

Figure 3 The hydraulic path of the Binary Pump with bypassed damper and mixer

For pump specifications, see “[Performance Specifications](#)” on page 30.

Product Description

The Agilent 1260 Infinity II Binary Pump is suited for LC applications using conventional or superficially porous particles columns, as well as STM column technology. Gradient formation is based on a high-pressure mixing principle. Standard or low delay volumes can be easily configured by the user. The Agilent 1260 Infinity II Binary Pump offers reproducible gradients and high-performance, providing high-throughput and fast separations. The pump is suitable for routine applications, with UV or MS detection, where high speed and resolution with uncompromised data quality are required.

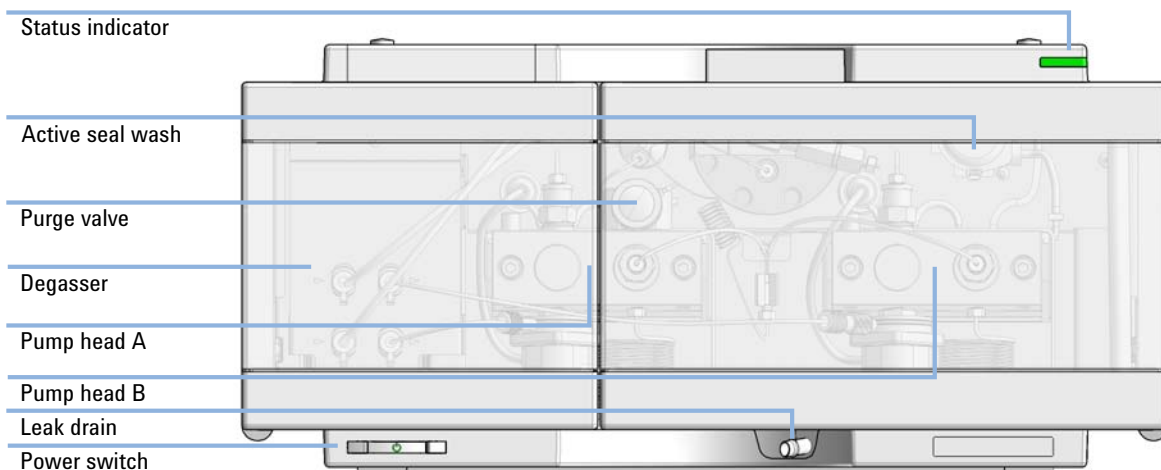

Figure 4 Overview of the pump

Features

- Configurable delay volume - down to 120 μL together with a flow range up to 5 mL/min provides universal applicability.
- Change from standard to low delay volume configuration is enabled.
- High gradient performance - even at low % B and narrow-bore flow rates.
- Integrated 2-channel-degasser.
- Fast and precise gradients using LC/MS, as well as UV-only systems.
- Fully exploits the speed and separation potential of Poroshell.

Overview of the Hydraulic Path

The solvent from the bottle in the solvent cabinet enters the pump through an active inlet valve. Each side of the binary pump comprises two substantially identical pump units. Both pump units comprise a ball-screw drive and a pump head with two sapphire pistons for reciprocating movement.

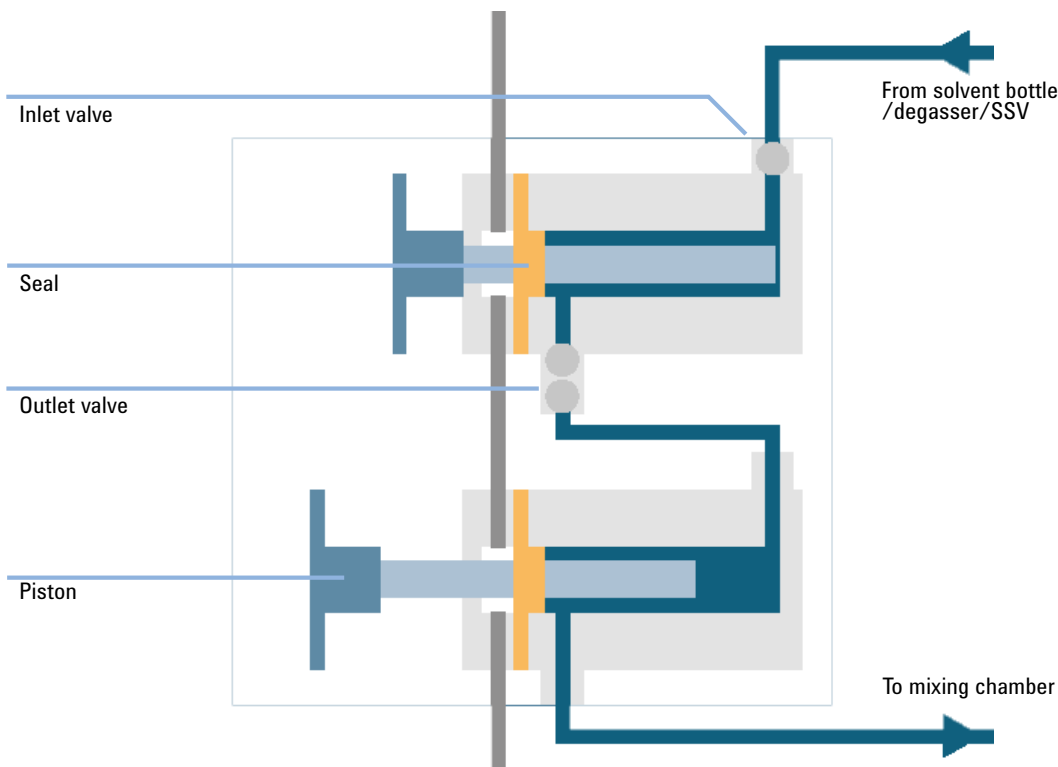

Figure 5 Pump head

A servo-controlled variable reluctance motor drives the two ball-screw drives in opposite directions. The gears for the ball-screw drives have different circumferences (ratio 2:1) allowing the first piston to move at double the speed of the second piston. The solvent enters the pump heads close to the bottom limit and leaves it at its top. The outer diameter of the piston is smaller than

the inner diameter of the pump-head chamber allowing the solvent to fill the gap in between. The first piston has a stroke volume in the range of 20 μL to 100 μL depending on the flow rate. The microprocessor controls all flow rates in a range of 1 $\mu\text{L}/\text{min}$ to 5 mL/min . The inlet of the first pumping unit is connected to the active inlet valve which is processor-controlled opened or closed allowing solvent to be drawn into the first pump unit.

The outlet of the first pump chamber is connected by a 500 μL absorber capillary to the second pump chamber. The outlets of the second chambers of both pump channels joined via a small mixing chamber. A coiled restriction capillary connects the mixing chamber via a pressure pulse damper, a mixer and a pressure sensor to the purge valve assembly. The outlet of the purge valve assembly is then connected to the attached chromatographic system.

When turned on, the pump runs through an initialization procedure to determine the upper dead center of the first piston of both pump channels. The first piston moves slowly upwards to the mechanical stop of the pump head and from there it moves back a predetermined path length. The controller stores this piston position in memory. After this initialization the pump starts operation with the set parameters for the two pump channels.

The active inlet valve is opened and the down moving piston draws solvent into the first pump head. At the same time the second piston is moving upwards delivering into the system. After a controller defined stroke length (depending on the flow rate) the drive motors are stopped and the active inlet valve is closed. The motor direction is reversed and moves the first piston up until it reaches the stored upper limit and at the same time moving the second piston downwards.

Then the sequence starts again moving the pistons up and down between the two limits. During the delivery stroke of the first piston the solvent in the pump head is pressed through the outlet valve into the second pumping unit. The second piston draws in half of the volume displaced by the first piston and the remaining half volume is directly delivered into the system. During the drawing stroke of the first piston, the second piston delivers the drawn volume into the system.

For pump specifications, see [“Performance Specifications”](#) on page 30.

What is Pump Elasticity Compensation?

The flow path of the pump consists of pump chambers, sapphire pistons, polymer seals, stainless steel tubing of different dimension, pressure sensor, and so forth. All of these parts deform when pressurized. The sum of this deformation is called pump elasticity.

Let us look at a practical example: Piston 1 draws solvent at ambient pressure. The movement direction is reversed and the piston 1 now compresses the solvent until the operating pressure of the HPLC system is reached. The outlet valve opens, and solvent is pumped by piston 1 into pump chamber 2. Due to two factors, the solvent volume that is delivered into the system at high pressure is smaller than it is supposed to be:

- 1 The solvent is compressible
- 2 The pump has a certain elasticity which causes its internal volume to increase with pressure.

In order to compensate for these two influences, their contributions must be known. An elasticity calibration allows separating pump properties from solvent properties and therefore allows transferring solvent properties, which have been obtained from one pump to another pump with different elasticity.

Elasticity calibration is done with a solvent, which properties (compressibility, thermal expansion) are well-known and documented: pure water. When pumping water and using its property data for controlling the pump, any deviations from the theoretical pressure profile during solvent recompression are caused by the elasticity of the pump.

The *Pump Elasticity Calibration* calculates correction factors to compensate for the individual elasticity of the pump that is being calibrated. The elasticity is different for every pump and may change with the replacement of parts in the flow path, e.g. pump seals.

All binary pumps are elasticity calibrated at the factory and require recalibration only after preventive maintenance or major repairs to the flow path. Replacement of capillaries or PTFE frits are not considered as a major repair.

CAUTION

Incorrect pump elasticity calibration.

Solvent compressibility calibrations acquired with a miscalibrated pump will work, but they are not transferable to other pumps. A correct pump elasticity calibration is an essential prerequisite for successful solvent compressibility calibrations.

→ Calibrate the pump elasticity correctly.

What is Solvent Compressibility Compensation?

Although the compressibility of liquids is orders of magnitude lower than the compressibility of gases, without correction a noticeable volume error would be seen if typical chromatographic solvents are compressed to operating pressures as high as 600 bar. In addition, the compressibility depends on pressure, temperature and the amount of dissolved gas. In order to minimize the influence of the latter, the use of a vacuum degasser is mandatory for a high flow and composition precision. Unfortunately, the influence of the temperature on compressibility is non-linear and cannot be calculated.

The Agilent 1260 Infinity II Binary Pump features a multi point compressibility calibration. The compressibility of a solvent is determined at different pressures from 0 – 600 bar and stored in an XML file. This file can be distributed to other pumps because the solvent compressibility is independent from the pump.

The binary pump and ChemStation come with predetermined solvent compressibility data for the most common HPLC solvents like water, acetonitrile, methanol, etc. Users can calibrate their own solvent mixtures with the help of an easy to use calibration procedure in the Agilent Lab Advisor software.

Let us use the practical example from the last section once again to understand how compressibility compensation works:

Piston 1 draws solvent at ambient pressure. The movement direction is reversed and piston 1 now compresses the solvent until the operating pressure of the HPLC system is reached. The outlet valve opens, and solvent is pumped by piston 1 into pump chamber 2.

Without any compensation, the delivered volume at operating pressure would be too low. In addition, it would take a noticeable amount of time to recompress the solvent to operating pressure. During this time frame, no solvent would be delivered into the system and as a result a high pressure fluctuation (known as *pressure ripple*) would be observed.

When both solvent compressibility at the current operating pressure and pump elasticity are known, the pump can automatically correct for the missing volume by drawing the appropriate larger solvent volume at ambient pressure and speed up the piston during the recompression phase in the first pump chamber. As a result, the pump delivers the accurate volume with any (calibrated) solvent at any pressure at a greatly reduced pressure ripple.

For applications that require lowest transition volume of the pump, damper and mixer can be bypassed.

For compatibility with older methods from G1312A Binary Pumps, the previous one-point compressibility compensation is available, too. However, since the compressibility is a non-linear function, one single compressibility value per solvent will only give good results at one particular pressure.

How Does Variable Stroke Volume Work?

The smaller the solvent volume in the pump chamber is, the faster it can be recompressed to operating pressure. The binary pump allows to manually or automatically adjust the pump stroke volume of the first piston in the range of 20 – 100 μL . Due to the compression of the solvent volume in the first pump chamber, each piston stroke of the pump will generate a small pressure pulsation, influencing the flow ripple of the pump. The amplitude of the pressure pulsation mainly depends on the stroke volume and the compressibility compensation for the solvent in use. Small stroke volumes generate less pressure pulsation than larger stroke volumes at the same flow rate. In addition, the frequency of the pressure pulsation will be higher. This will decrease the influence of flow pulsations on retention times.

In gradient mode, a smaller stroke volume results in less flow ripple and reduces the composition ripple.

The binary pump uses a processor-controlled ball screw system for driving its pistons. The normal stroke volume is optimized for the selected flow rate. Small flow rates use a small stroke volume while higher flow rates use a higher stroke volume.

The stroke volume for the pump is by default set to AUTO mode. This means that the stroke is optimized for the flow rate in use. A change to larger stroke volumes is possible but not recommended.

Leak and Waste Handling

The Agilent InfinityLab LC Series has been designed for safe leak and waste handling. It is important that all security concepts are understood and instructions are carefully followed.

The solvent cabinet is designed to store a maximum volume of 8 L solvent. The maximum volume for an individual bottle stored in the solvent cabinet should not exceed 2 L. For details, see the usage guideline for the Agilent Infinity II Solvent Cabinets (a printed copy of the guideline has been shipped with the solvent cabinet, electronic copies are available on the Internet).

All leak plane outlets are situated in a consistent position so that all Infinity and Infinity II modules can be stacked on top of each other. Waste tubes are guided through a channel on the right hand side of the instrument, keeping the front access clear from tubes.

The leak plane provides leak management by catching all internal liquid leaks, guiding them to the leak sensor for leak detection, and passing them on to the next module below, if the leak sensor fails. The leak sensor in the leak plane stops the running system as soon as the leak detection level is reached.

Solvent and condensate is guided through the waste channel into the waste container:

- from the detector's flow cell outlet
- from the Multisampler needle wash port
- from the Sample Cooler or Sample Thermostat (condensate)
- from the pump's Seal Wash Sensor (if applicable)
- from the pump's Purge Valve or Multipurpose Valve

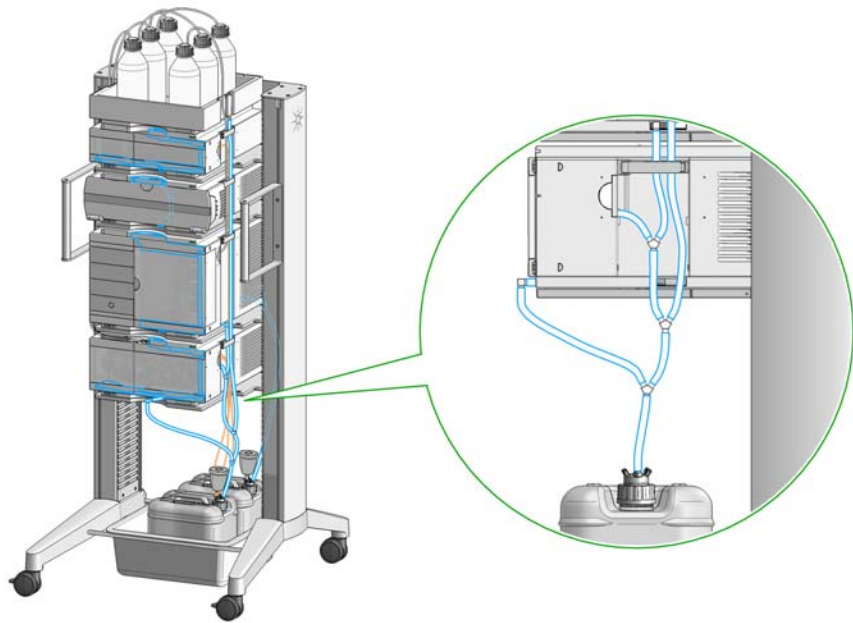

Figure 6 Infinity II Leak Waste Concept (Flex Bench installation)

1 Introduction
Leak and Waste Handling

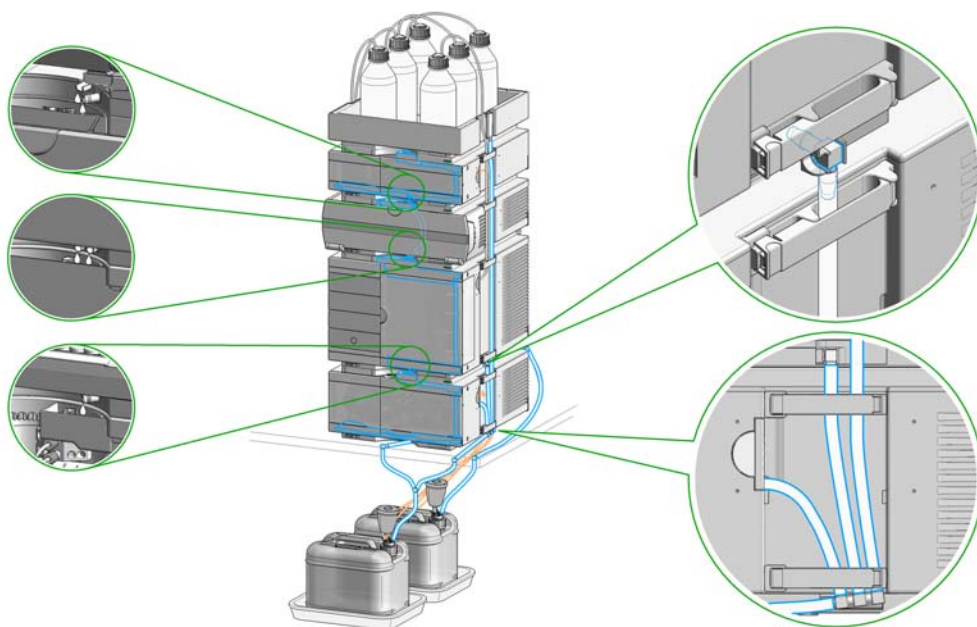

Figure 7 Infinity II Single Stack Leak Waste Concept (bench installation)

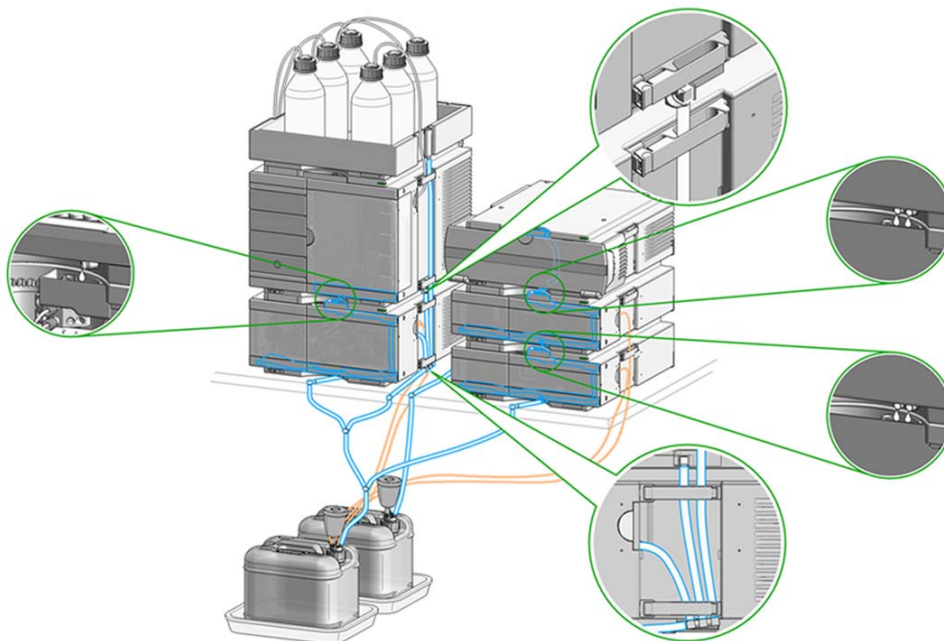

Figure 8 Infinity II Two Stack Leak Waste Concept (bench installation)

The waste tube connected to the leak pan outlet on each of the bottom instruments guides the solvent to a suitable waste container.

Leak Sensor

CAUTION

Solvent incompatibility

The solvent DMF (dimethyl formamide) leads to corrosion of the leak sensor. The material of the leak sensor, PVDF (polyvinylidene fluoride), is incompatible with DMF.

→ Do not use DMF.

Waste Concept

- 1 Agilent recommends using the 6 L waste can with 1 Stay Safe cap GL45 with 4 ports (5043-1221) for optimal and safe waste disposal. If you decide to use your own waste solution, make sure that the tubes don't immerse in the liquid.



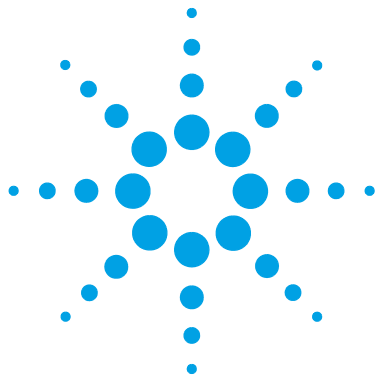

2 Site Requirements and Specifications

Site Requirements	26
Physical Specifications	29
Performance Specifications	30

This chapter provides information about site requirements and specifications for the binary pump.



Site Requirements

A suitable environment is important to ensure optimal performance of the instrument.

Power Considerations

The module power supply has wide ranging capability. It accepts any line voltage in the range described in [Table 1](#) on page 29. Consequently there is no voltage selector in the rear of the module. There are also no externally accessible fuses, because automatic electronic fuses are implemented in the power supply.

WARNING

Hazard of electrical shock or damage of your instrumentation can result, if the devices are connected to a line voltage higher than specified.

→ Connect your instrument to the specified line voltage only.

WARNING

Electrical shock hazard

The module is partially energized when switched off, as long as the power cord is plugged in.

The cover protects users from personal injuries, for example electrical shock.

→ Do not open the cover.

→ Do not operate the instrument and disconnect the power cable in case the cover has any signs of damage.

→ Contact Agilent for support and request an instrument repair service.

WARNING

Inaccessible power plug.

In case of emergency it must be possible to disconnect the instrument from the power line at any time.

→ Make sure the power connector of the instrument can be easily reached and unplugged.

→ Provide sufficient space behind the power socket of the instrument to unplug the cable.

Power Cords

Country-specific power cords are available for the module. The female end of all power cords is identical. It plugs into the power-input socket at the rear. The male end of each power cord is different and designed to match the wall socket of a particular country or region.

Agilent makes sure that your instrument is shipped with the power cord that is suitable for your particular country or region.

WARNING

Unintended use of power cords

Using power cords for unintended purposes can lead to personal injury or damage of electronic equipment.

- Never use a power cord other than the one that Agilent shipped with this instrument.
 - Never use the power cords that Agilent Technologies supplies with this instrument for any other equipment.
 - Never use cables other than the ones supplied by Agilent Technologies to ensure proper functionality and compliance with safety or EMC regulations.
-

WARNING

Absence of ground connection

The absence of ground connection can lead to electric shock or short circuit.

- Never operate your instrumentation from a power outlet that has no ground connection.
-

WARNING

Electrical shock hazard

Solvents may damage electrical cables.

- Prevent electrical cables from getting in contact with solvents.
 - Exchange electrical cables after contact with solvents.
-

Bench Space

The module dimensions and weight (see [Table 1](#) on page 29) allow you to place the module on almost any desk or laboratory bench. It needs an additional 2.5 cm (1.0 inches) of space on either side and approximately 8 cm (3.1 inches) in the rear for air circulation and electric connections.

If the bench shall carry a complete HPLC system, make sure that the bench is designed to bear the weight of all modules.

The module should be operated in a horizontal position.

NOTE

Agilent recommends that you install the HPLC instrument in the InfinityLab Flex Bench rack. This option helps to save bench space as all modules can be placed into one single stack. It also allows to easily relocate the instrument to another Lab.

Condensation

CAUTION

Condensation within the module

Condensation can damage the system electronics.

- Do not store, ship or use your module under conditions where temperature fluctuations could cause condensation within the module.
 - If your module was shipped in cold weather, leave it in its box and allow it to warm slowly to room temperature to avoid condensation.
-

Physical Specifications

Table 1 Physical Specifications

Type	Specification	Comments
Weight	17.6 kg (38.8 lbs)	
Dimensions (height × width × depth)	180 x 396 x 436 mm (7.1 x 15.6 x 17.2 inches)	
Line voltage	100 – 240 V~, ± 10 %	Wide-ranging capability
Line frequency	50 or 60 Hz, ± 5 %	
Power consumption	90 VA / 74 W	
Ambient operating temperature	4–55 °C (39–131 °F)	
Ambient non-operating temperature	-40 – 70 °C (-40 – 158 °F)	
Humidity	< 95 % r.h. at 40 °C (104 °F)	Non-condensing
Operating altitude	Up to 3000 m (9842 ft)	
Non-operating altitude	Up to 4600 m (15092 ft)	For storing the module
Safety standards: IEC, EN, CSA, UL	Installation category II, Pollution degree 2	For indoor use only.
ISM Classification	ISM Group 1 Class B	According to CISPR 11

Performance Specifications

Table 2 Performance Specifications 1260 Infinity II Binary Pump (G7112B)

Type	Specification	Comments
Hydraulic system	Two dual piston in series pumps with servo-controlled variable stroke drive, power transmission by gears and ball screws, floating pistons	
Flow range	settable: 0.001 – 5 mL/min recommended: 0.05 – 5.0 mL/min	Set points in 0.001 mL/min increments
Flow precision	≤0.07 % RSD or < 0.02 min SD, whichever is greater	based on retention time at constant temperature
Flow accuracy	± 1 % or 10 µL/min, whichever is greater	pumping degassed H ₂ O at 10 MPa (100 bar, 1450 psi)
Pressure operating range	Up to 60 MPa (600 bar, 8702 psi) up to 5 mL/min	
Pressure pulsation	< 2 % amplitude (typically < 1.3 %), or < 0.3 MPa (3 bar, 44 psi), whichever is greater <i>Low delay volume configuration:</i> < 5 % amplitude (typically < 2 %)	
Compressibility compensation	Pre-defined, based on mobile phase compressibility	
Recommended pH range	1.0 – 12.5	Solvents with pH < 2.3 should not contain acids that attack stainless steel
Gradient formation	High-pressure binary mixing	
Delay volume	<i>Standard delay volume configuration:</i> 600 – 900 µL, (includes 400 µL mixer), dependent on back pressure <i>Low delay volume configuration:</i> 120 µL	measured with water at 1 mL/min (water/water with tracer)

Table 2 Performance Specifications 1260 Infinity II Binary Pump (G7112B)

Type	Specification	Comments
Composition range	settable: 0 – 100 % recommended: 1 – 99 % or 5 µL/min per channel, whichever is greater	
Composition precision	< 0.15 % RSD or < 0.04 min SD, whichever is greater	at 0.2 and 1 mL/min; based on retention time at constant temperature
Composition accuracy	± 0.35 % absolute	at 2 mL/min, at 10 MPa (100 bar, 1450 psi) (water/water with tracer)
Integrated degassing unit	Number of channels: 2 Internal volume per channel: 1.5 mL	
Instrument Control	Agilent control software with LC and CE Drivers A.02.14 or above Lab Advisor B.02.09 or above Agilent Instant Pilot (G4208A) with firmware B.02.20 or above Instrument Control Framework (ICF) A.02.04 or above	For details about supported software versions refer to the compatibility matrix of your version of the LC and CE Drivers
Communications	Controller-area network (CAN), Extended Remote Interface (ERI), Local Area Network (LAN)	
Safety and maintenance	Extensive diagnostics, error detection and display through Agilent LabAdvisor, leak detection, safe leak handling, leak output signal for shutdown of the pumping system. Low voltage in major maintenance areas.	
GLP features	Early maintenance feedback (EMF) for continuous tracking of instrument usage in terms of seal wear and volume of pumped mobile phase with pre-defined and user settable limits and feedback messages. Electronic records of maintenance and errors.	
Housing	All materials are recyclable	

2 Site Requirements and Specifications

Performance Specifications

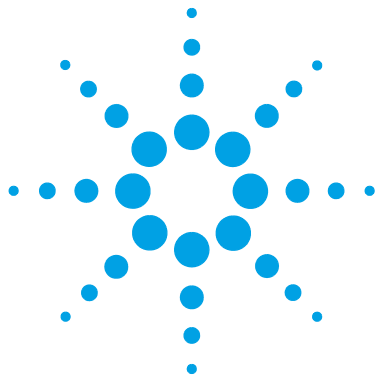

3 Using the Pump

Magnets	34
Turn on/off	35
Status Indicators	37
Best Practices	38
Daily / Weekly tasks	38
Power up / Shut-down the pump	38
Prepare the pump	39
How to deal with solvents	39
Leak and Waste Handling	40
Hints for Successful Use of the Binary Pump	41
Setting up the Pump with the G4208A Instant Pilot	42
Setting up the Pump with the Instrument Control Interface	43
Overview	43
Setup of Basic Pump Parameters	44
Pump Control	45
Auxiliary Pump Parameters	45
Data Curves	46
Bottle Filling	47
Solvent Information	48
Algae Growth in HPLC Systems	54
How to Prevent and/or Reduce the Algae Problem	54
Prevent Blocking of Solvent Filters	55
Checking the Solvent Filters	55
Cleaning the Solvent Filters	56
Normal Phase Applications	57

This chapter explains the operational parameters of the Binary Pump.



3 Using the Pump Magnets

Magnets

- 1 This stack exemplarily shows the magnets' positions in the modules.

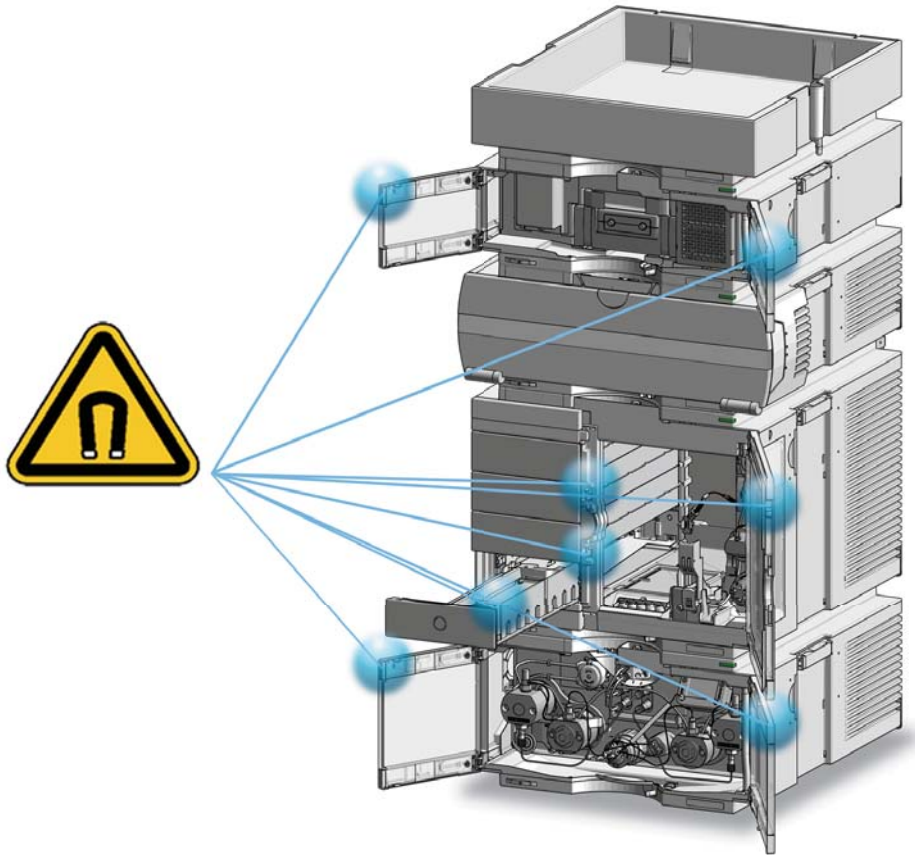

Turn on/off

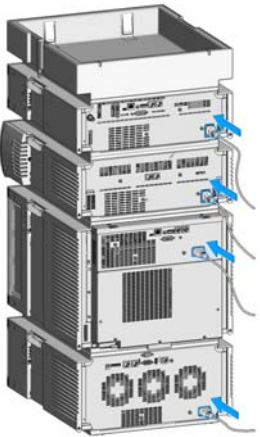
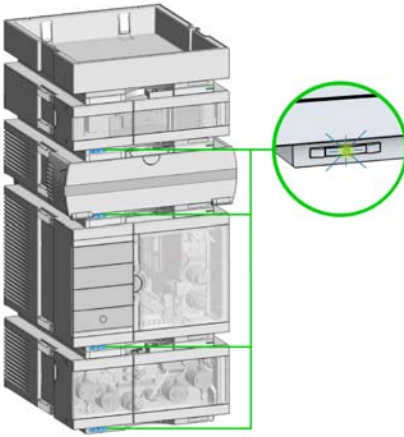
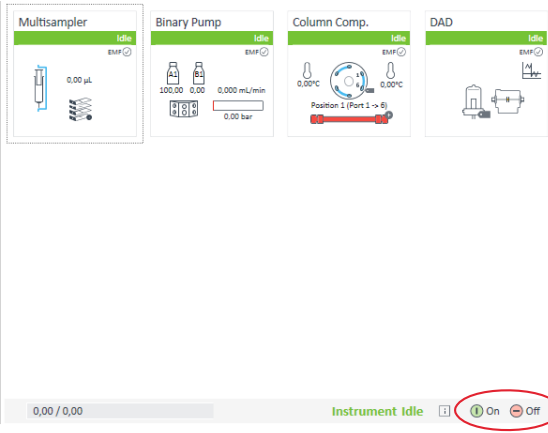
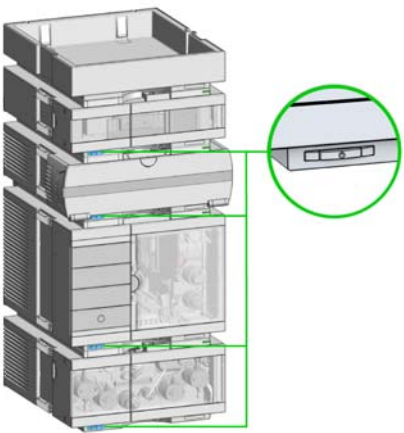
<p>1</p> 	<p>2</p>  <p>Power switch: On</p>
<p>3 Turn instrument On/Off with the control software.</p> 	<p>4</p>  <p>Power switch: Off</p>

3 Using the Pump

Turn on/off

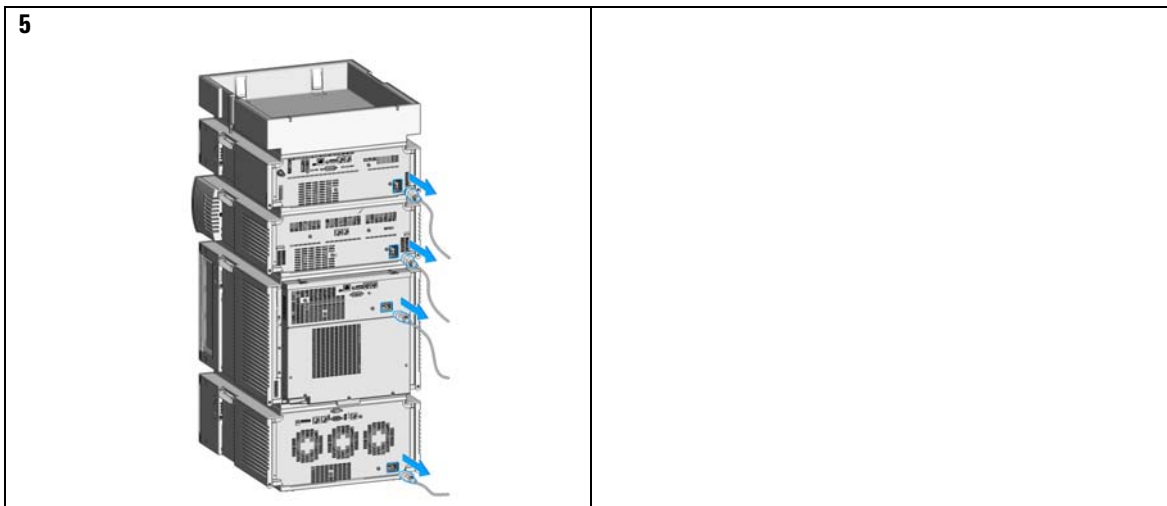

Status Indicators

- 1 The module status indicator indicates one of six possible module conditions:

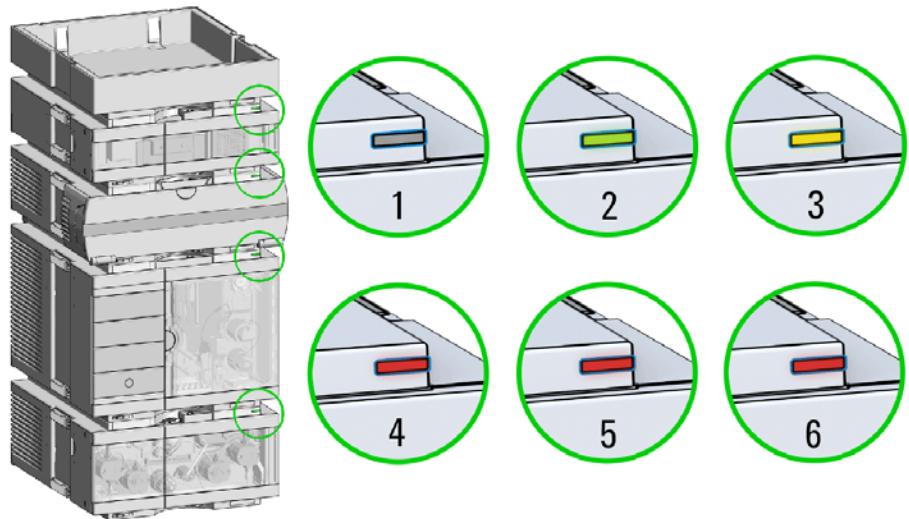

Status indicators

1. Idle
2. Run mode
3. Not-ready. Waiting for a specific pre-run condition to be reached or completed.
4. Error mode - interrupts the analysis and requires attention (for example a leak or defective internal components).
5. Resident mode (blinking) - for example during update of main firmware.
6. Bootloader mode (fast blinking). Try to re-boot the module or try a cold-start. Then try a firmware update.

Best Practices

Daily / Weekly tasks

Daily tasks

- Replace mobile phase based on water/buffer.
- Replace organic mobile phase latest every second day.
- Check seal wash solvent.

Weekly tasks

- Change seal wash solvent (10 % / 90 % isopropanol/water) and bottle.
- Flush all channels with water at 2.5 – 3 mL/min for 5 min to remove salt deposits if buffer applications were used.
- Inspect solvent filters for dirt or blockages. Clean or exchange if no flow is coming out of the solvent line when removed from the degasser inlet.

Power up / Shut-down the pump

Power up the pump

- Use new or different mobile phase (as required).
- Purge pump heads with 2.5 – 3 mL/min for 5 min.
- Stabilize the system by running for 10 – 20 min.

Long-term shut-down of the system

- Flush system with water to remove buffer.
- Remove all samples from the sampler and store according to good laboratory practice.
- Use recommended solvents to store the system.
- Power off the system.

Prepare the pump

Purge

Use the Purge function to:

- fill the pump,
- exchange a solvent,
- remove air bubbles in tubes and pump heads.

Seal wash

Seal Wash guarantees a maximum seal life time. Use Seal Wash:

- When using buffers with elevated salt concentrations
- When using volatile solvents with non-volatile additives

CAUTION

Contaminated seal wash solvent

- Do not recycle seal wash solvent to avoid contamination.
 - Weekly exchange seal wash solvent.
-

How to deal with solvents

- Use clean bottles only.
- Exchange water-based solvents daily.
- Select solvent volume to be used up within 1 – 2 days.
- Use only HPLC-grade solvents and water filtered through 0.2 µm filters.
- Label bottles correctly with bottle content, and filling date / expiry date.
- Use solvent inlet filters.
- Reduce risk of algae growth: use brown bottles for aqueous solvents, avoid direct sunlight.

Leak and Waste Handling

WARNING

Toxic, flammable and hazardous solvents, samples and reagents

The handling of solvents, samples and reagents can hold health and safety risks.

- When working with these substances observe appropriate safety procedures (for example by wearing goggles, safety gloves and protective clothing) as described in the material handling and safety data sheet supplied by the vendor, and follow good laboratory practice.
- Do not use solvents with an auto-ignition temperature below 200 °C (392 °F). Do not use solvents with a boiling point below 56 °C (133 °F).
- Avoid high vapor concentrations. Always keep the temperature in the sample compartment at least 25 K below the boiling point of the solvent used.
- Do not operate the instrument in an explosive atmosphere.
- Do not use solvents of ignition Class IIC according IEC 60079-20-1 (for example, carbon disulfide).
- Reduce the volume of substances to the minimum required for the analysis.
- Never exceed the maximum permissible volume of solvents (8 L) in the solvent cabinet. Do not use bottles that exceed the maximum permissible volume as specified in the usage guideline for solvent cabinet.
- Ground the waste container.
- Regularly check the filling level of the waste container. The residual free volume in the waste container must be large enough to collect the waste liquid.
- To achieve maximal safety, regularly check the tubing for correct installation.

NOTE

For details, see the usage guideline for the solvent cabinet. A printed copy of the guideline has been shipped with the solvent cabinet, electronic copies are available in the Agilent Information Center or via the Internet.

For details on correct installation, see separate installation documentation.

Hints for Successful Use of the Binary Pump

- Place solvent cabinet with the solvent bottles always on top (or at a higher level) of the pump.
- Flush the degasser with at least 5 mL per channel before operating the pump, especially when the pumping system had been turned off for a certain length of time (for example, overnight) and volatile solvent mixtures are used in the channels.
- Prevent blocking of solvent inlet filters (never use the pump without solvent inlet filters). Growth of algae should be avoided (see [“Prevent Blocking of Solvent Filters”](#) on page 55).
- Check purge valve frit and column frit in regular time intervals. A blocked purge valve frit can be identified by black, yellow or greenish layers on its surface or by a pressure greater than 10 bar in low delay volume configuration and 20 bar in standard configuration when pumping distilled water at a rate of 5 mL/min with an open purge valve.
- Whenever possible use a minimum flow rate of 5 $\mu\text{L}/\text{min}$ per solvent channel to avoid crossflow of solvent into the unused pump channel.
- Whenever exchanging the pump seals, the purge valve frit should be exchanged, too.
- When using buffer solutions, flush the system with water before switching it off. The seal wash option should be used when installed, especially when buffer solutions with concentrations of 0.1 M or higher are being pumped for long periods of time.
- Check the pump pistons for scratches, grooves and dents when changing the piston seals. Damaged pistons cause micro leaks and will decrease the lifetime of the seals.
- After changing the piston seals, apply the seal wear-in procedure (see [“Seal Wear-in Procedure”](#) on page 136).
- Place the aqueous solvent on channel A and the organic solvent on channel B. The default compressibility settings are set accordingly.

3 Using the Pump

Setting up the Pump with the G4208A Instant Pilot

Setting up the Pump with the G4208A Instant Pilot

Generic operation of the G4208A Instant Pilot is covered in the Agilent Instant Pilot G4208A User's Guide (G4208-90006). Details about setting up module specific parameters can be found in the Instant Pilot online help.

The pump parameters are described in detail in [“Overview”](#) on page 43.

Setting up the Pump with the Instrument Control Interface

Overview

Parameters described in following sections are offered by the instrument control interface and can usually be accessed through Agilent instrument control software. For details, please refer to manuals and online help of respective user interfaces.

Setup of Basic Pump Parameters

The most important parameters of the pump are listed in [Table 3](#) on page 44.

Table 3 Basic pump parameters

Parameter	Limits	Description
• Flow	0.001 – 5 mL/min	Total flow rate of the pump. See “When to Remove Damper and Mixer” on page 63 for pump hardware modifications to achieve lowest delay volume.
• Stop Time	0.01 min - no limit	The stop time of the pump usually controls the run time of the whole LC system. Use no limit to stop the run manually (useful for method development).
• Post Time	off - 99999 min	Time between the end of a run and the start of the next. Used for column equilibration after a gradient.
• Pressure Limits	Max: 0 – 600 bar Min: 0 – 600 bar	Max must be bigger than Min ! Set max pressure to the maximum operating pressure of your column. A min pressure setting of e.g. 10 bar will turn off your pump automatically when running out of solvent. A smarter way, however, is to use the bottle fillings function (see “Bottle Filling” on page 47).
• Solvent A	0 – 100 %	Although channel A can be set to 0 %, it cannot be turned off. This channel should be used for the aqueous phase (water).
• Solvent B	off - 100 %	The percentage of channel B is automatically complemented by channel A to give 100 %.
• Solvent type	H ₂ O, ACN, MeOH, IPA	Select the solvent you are using in the respective solvent channel from the drop-down list. In case your solvent is not listed, perform a solvent compressibility calibration (see “Running the Solvent Compressibility Calibration” on page 104). For details on solvent compressibility see “Binary Pump Solvent Compressibility Calibration” on page 103.
• Solvent Comment		Free text field for a description of the solvent. This description will show up in method printouts, etc.
• Timetable	max. number of lines depends on free space in pump memory	Use the timetable to build solvent gradients, flow gradients, or combinations of both. Gradients are always linear. Use multiple timetable entries to mimic exponential or parabolic gradients.
• Display		There are three ways to display the timetable: <ul style="list-style-type: none"> • in tabular form • as flow/pressure graph • as solvent percentage plot Values can only be changed in tabular view.

Pump Control

The pump can be switched between following states: **On**, **Off** or to **Standby**. In **Standby**, the pump motor is still controlled. When the pump is switched on from standby, it does not re-initialize.

CAUTION

Upon initialization, the pump ignores the Maximum Flow Gradient value.

This can result in a rapid and uncontrolled pressure increase.

→ To prevent harm to the column, open the purge valve until the initialization is finished.

The optional seal wash pump can be controlled by either switching it off, using it for a single time or specifying frequency and duration of periodic wash intervals.

Auxiliary Pump Parameters

The auxiliary pump parameters are pre-set to fit most applications. Adjustments should only be made when required. [Table 4](#) on page 46 shows the available auxiliary parameters with their default values.

CAUTION

Upon initialization, the pump ignores the Maximum Flow Gradient value.

This can result in a rapid and uncontrolled pressure increase.

→ To prevent harm to the column, open the purge valve until the initialization is finished.

3 Using the Pump

Setting up the Pump with the Instrument Control Interface

Table 4 Auxiliary pump parameters

Parameter	Limits	Description
• Maximum Flow Gradient	0.1 – 100 mL/min ² default: 100 mL/min ²	With this parameter flow rate changes can be ramped up and down slowly to avoid pressure shocks to the column. The default value is 100 mL/min ² which in fact turns the function off.
• Minimum Stroke	20 – 100 µL default: Auto	The volume one pump piston delivers per stroke. In general, a smaller stroke volume results in lower pump ripple. The Auto setting adjusts the strokes dynamically to the lowest possible value. The strokes can be set individually for pump heads A and B.
• Compressibility	0 - 150·10 ⁻⁶ /bar or enhanced compressibility calibration default: use enhanced comp. calibration	For best performance, check option Use enhanced compressibility calibration . With this option, the pump will use solvent data libraries provided by Agilent or data generated by using solvent compressibility calibrations (see “ Running the Solvent Compressibility Calibration ” on page 104). For details on solvent compressibility see “ Binary Pump Solvent Compressibility Calibration ” on page 103. For backward compatibility to 400 bar pumps, the solvent compressibility can still be set manually for each channel when the box is unticked.

Data Curves

The binary pump provides the possibility to store the following operational data in the data file of the Agilent data system:

- Solvent percentage for each channel,
- pump flow,
- pressure

NOTE

The pressure data curve is *generated* from the pressure sensor readings, while %A, %B and flow are *calculated* from the method settings of the pump.

For details, please refer to the online help or manual of your instrument control software.

Bottle Filling

The pump offers a powerful feature to monitor the liquid level in the solvent bottles. With total bottle volume and initial filling volume set correctly, the pump subtracts the consumed volume continuously from the initial value and stops the pump and method/sequence execution before the system runs dry or an analysis is corrupted.

CAUTION

The bottle filling feature fails if multiple solvent inlets are put into one solvent bottle!

→ In that case implement a minimum pressure limit to avoid that the pump runs dry when solvents are empty.

Table 5 on page 47 lists the available bottle filling parameters.

Table 5 Bottle Filling Parameters

Parameter	Limits	Description
• Total Volume	0 – 1000 L default: 0 L	This is the capacity (maximum possible volume) in liter of the solvent bottle. In combination with the actual volume, this parameter is used for calculating and displaying the relative liquid level.
• Actual Volume	0 – 1000 L default: 0 L	After filling the solvent bottles, enter the actual volumes into these boxes. The Actual Volume must not be larger than the Total Volume of the bottle.
• Prevent analysis.....	default: unchecked	If this option is checked, the pump won't start a new run if the solvent level in one or more bottles is below the minimum volume. Enter a minimum volume in liter, which considers the position of the solvent inlet and size/shape of the solvent bottle such that no air is drawn if the actual volume gets close to this limit.
• Turn pump off...	default: unchecked	If this option is checked, the pump will turn off before air is aspirated. However, the residual solvent volume has been calculated for 1 L solvent bottles and may be too small for large bottles or other vessels.

Solvent Information

Observe the following recommendations on the use of solvents.

- Follow recommendations for avoiding the growth of algae, see “[Algae Growth in HPLC Systems](#)” on page 54
- Small particles can permanently block capillaries and valves. Therefore, always filter solvents through 0.22 µm filters.
- Avoid or minimize the use of solvents that may corrode parts in the flow path. Consider specifications for the pH range given for different materials like flow cells, valve materials etc. and recommendations in subsequent sections.

Materials in Flow Path

Following materials are used in the flow path of this module:

Table 6 Materials in flow path

Part	Materials
Degasser chamber	TFE/PDD Copolymer, PFA (internal tubings), PEEK (inlets), FEP (tubings), ETFE (fittings)
SSV	PEEK, FFKM
Active inlet valve	SST, sapphire, ruby, ceramic, PTFE
Outlet valve	SST, gold, ruby, ZrO ₂ -based ceramic, tantalum
Adapter	SST, gold
Pump head (body)	SST
Pistons	Sapphire
Piston seals/wash seals	PTFE, SST (reversed phase) or UHMW-PE, SST (normal phase)
Pressure sensor	SST
Purge valve	SST, gold, PTFE, ceramic
Damping unit	SST, gold
Capillaries/fittings	SST
Tubings	PTFE

Material Information

Materials in the flow path are carefully selected based on Agilent's experiences in developing highest quality instruments for HPLC analysis over several decades. These materials exhibit excellent robustness under typical HPLC conditions. For any special condition, please consult the material information section or contact Agilent.

Disclaimer

Subsequent data was collected from external resources and is meant as a reference. Agilent cannot guarantee the correctness and completeness of such information. Data is based on compatibility libraries, which are not specific for estimating the long-term life time under specific but highly variable conditions of UHPLC systems, solvents, solvent mixtures and samples. Information can also not be generalized due to catalytic effects of impurities like metal ions, complexing agents, oxygen etc. Apart from pure chemical corrosion, other effects like electro corrosion, electrostatic charging (especially for non-conductive organic solvents), swelling of polymer parts etc. need to be considered. Most data available refers to room temperature (typically 20 – 25 °C, 68 – 77 °F). If corrosion is possible, it usually accelerates at higher temperatures. If in doubt, please consult technical literature on chemical compatibility of materials.

PEEK

PEEK (Polyether-Ether Ketones) combines excellent properties regarding biocompatibility, chemical resistance, mechanical and thermal stability. PEEK is therefore the material of choice for UHPLC and biochemical instrumentation.

It is stable in the specified pH range (for the Bio-inert LC system: pH 1 – 13, see bio-inert module manuals for details), and inert to many common solvents.

There is still a number of known incompatibilities with chemicals such as chloroform, methylene chloride, THF, DMSO, strong acids (nitric acid > 10 %, sulphuric acid > 10 %, sulfonic acids, trichloroacetic acid), halogenes or aqueous halogene solutions, phenol and derivatives (cresols, salicylic acid etc.).

When used above room temperature, PEEK is sensitive to bases and various organic solvents, which can cause it to swell. Under such conditions normal PEEK capillaries are very sensitive to high pressure. Therefore Agilent uses stainless-steel clad PEEK capillaries in bio-inert systems. The use of stainless steel clad PEEK capillaries keeps the flow path free of steel and ensures pressure stability to at least 600 bar. If in doubt, consult the available literature about the chemical compatibility of PEEK.

Polyimide

Agilent uses semi-crystalline polyimide for rotor seals in valves and needle seats in autosamplers. One supplier of polyimide is DuPont, which brands polyimide as Vespel, which is also used by Agilent.

Polyimide is stable in a pH range between 1 and 10 and in most organic solvents. It is incompatible with concentrated mineral acids (e.g. sulphuric acid), glacial acetic acid, DMSO and THF. It is also degraded by nucleophilic substances like ammonia (e.g. ammonium salts in basic conditions) or acetates.

Polyethylene (PE)

Agilent uses UHMW (ultra-high molecular weight)-PE/PTFE blends for yellow piston and wash seals, which are used in 1290 Infinity pumps, 1290 Infinity II pumps, the G7104C and for normal phase applications in 1260 Infinity pumps.

Polyethylene has a good stability for most common inorganic solvents including acids and bases in a pH range of 1 to 12.5. It is compatible to many organic solvents used in chromatographic systems like methanol, acetonitrile and isopropanol. It has limited stability with aliphatic, aromatic and halogenated hydrocarbons, THF, phenol and derivatives, concentrated acids and bases. For normal phase applications, the maximum pressure should be limited to 200 bar.

Tantalum (Ta)

Tantalum is inert to most common HPLC solvents and almost all acids except fluoric acid and acids with free sulfur trioxide. It can be corroded by strong bases (e.g. hydroxide solutions > 10 %, diethylamine). It is not recommended for the use with fluoric acid and fluorides.

Stainless Steel (ST)

Stainless steel is inert against many common solvents. It is stable in the presence of acids and bases in a pH range of 1 to 12.5. It can be corroded by acids below pH 2.3. It can also corrode in following solvents:

- Solutions of alkali halides, their respective acids (for example, lithium iodide, potassium chloride, and so on) and aqueous solutions of halogens.
- High concentrations of inorganic acids like nitric acid, sulfuric acid and organic solvents especially at higher temperatures (replace, if your chromatography method allows, by phosphoric acid or phosphate buffer which are less corrosive against stainless steel).
- Halogenated solvents or mixtures which form radicals and/or acids, for example:

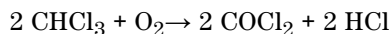

This reaction, in which stainless steel probably acts as a catalyst, occurs quickly with dried chloroform if the drying process removes the stabilizing alcohol.

- Chromatographic grade ethers, which can contain peroxides (for example, THF, dioxane, di-isopropylether). Such ethers should be filtered through dry aluminium oxide which adsorbs the peroxides.
- Solutions of organic acids (acetic acid, formic acid, and so on) in organic solvents. For example, a 1 % solution of acetic acid in methanol will attack steel.
- Solutions containing strong complexing agents (for example, EDTA, ethylene diamine tetra-acetic acid).
- Mixtures of carbon tetrachloride with 2-propanol or THF.

Titanium (Ti)

Titanium is highly resistant to oxidizing acids (for example, nitric, perchloric and hypochlorous acid) over a wide range of concentrations and temperatures. This is due to a thin oxide layer on the surface, which is stabilized by oxidizing compounds. Non-oxidizing acids (for example, hydrochloric, sulfuric and phosphoric acid) can cause slight corrosion, which increases with acid concentration and temperature. For example, the corrosion rate with 3 % HCl (about pH 0.1) at room temperature is about 13 $\mu\text{m}/\text{year}$. At room temperature, titanium is resistant to concentrations of about 5 % sulfuric acid (about pH 0.3). Addition of nitric acid to hydrochloric or sulfuric acids significantly reduces corrosion rates. Titanium is sensitive to acidic metal chlorides like FeCl_3 or CuCl_2 . Titanium is subject to corrosion in anhydrous methanol, which can be avoided by adding a small amount of water (about 3 %). Slight corrosion is possible with ammonia > 10 %.

Diamond-Like Carbon (DLC)

Diamond-Like Carbon is inert to almost all common acids, bases and solvents. There are no documented incompatibilities for HPLC applications.

Fused silica and Quartz (SiO_2)

Fused silica is used in Max Light Cartridges. Quartz is used for classical flow cell windows. It is inert against all common solvents and acids except hydrofluoric acid and acidic solvents containing fluorides. It is corroded by strong bases and should not be used above pH 12 at room temperature. The corrosion of flow cell windows can negatively affect measurement results. For a pH greater than 12, the use of flow cells with sapphire windows is recommended.

Gold

Gold is inert to all common HPLC solvents, acids and bases within the specified pH range. It can be corroded by complexing cyanides and concentrated acids like aqua regia.

Zirconium Oxide (ZrO_2)

Zirconium Oxide is inert to almost all common acids, bases and solvents. There are no documented incompatibilities for HPLC applications.

Platinum/Iridium

Platinum/Iridium is inert to almost all common acids, bases and solvents. There are no documented incompatibilities for HPLC applications.

Fluorinated polymers (PTFE, PFA, FEP, FFKM, PVDF)

Fluorinated polymers like PTFE (polytetrafluorethylene), PFA (perfluoroalkoxy) and FEP (fluorinated ethylene propylene) are inert to almost all common acids, bases, and solvents. FFKM is perfluorinated rubber, which is also resistant to most chemicals. As an elastomer, it may swell in some organic solvents like halogenated hydrocarbons.

TFE/PDD copolymer tubings, which are used in all Agilent degassers except G1322A, are not compatible with fluorinated solvents like Freon, Fluorinert, or Vertrel. They have limited life time in the presence of Hexafluoroisopropanol (HFIP). To ensure the longest possible life with HFIP, it is best to dedicate a particular chamber to this solvent, not to switch solvents, and not to let dry out the chamber. For optimizing the life of the pressure sensor, do not leave HFIP in the chamber when the unit is off.

The tubing of the leak sensor is made of PVDF (polyvinylidene fluoride), which is incompatible to the solvent DMF (dimethyl formamide).

Sapphire, Ruby and Al₂O₃-based ceramics

Sapphire, ruby and ceramics based on aluminum oxide Al₂O₃ are inert to almost all common acids, bases and solvents. There are no documented incompatibilities for HPLC applications.

Algae Growth in HPLC Systems

The presence of algae in HPLC systems can cause a variety of problems that may be incorrectly diagnosed as instrument or application problems. Algae grow in aqueous media, preferably in a pH range of 4-8. Their growth is accelerated by buffers, for example phosphate or acetate. Since algae grow through photosynthesis, light will also stimulate their growth. Even in distilled water small-sized algae grow after some time.

Instrumental Problems Associated With Algae

Algae deposit and grow everywhere within the HPLC system causing:

- Blocked solvent filters or deposits on inlet or outlet valves resulting in unstable flow, composition or gradient problems or a complete failure of the pump.
- Small pore high pressure solvent filters, usually placed before the injector to plug resulting in high system pressure.
- PTFE frits blockage leading to increased system pressure.
- Column filters to plug giving high system pressure.
- Flow cell windows of detectors to become dirty resulting in higher noise levels (since the detector is the last module in the flow path, this problem is less common).

How to Prevent and/or Reduce the Algae Problem

- Always use freshly prepared solvents, especially use demineralized water which was filtered through 0.2 μm filters.
- Never leave mobile phase in the instrument for several days without flow.
- Always discard old mobile phase.
- Use the amber solvent bottle (Solvent bottle, amber, 1000 mL (9301-6526)) supplied with the instrument for your aqueous mobile phase.
- If possible add a few mg/l sodium azide or a few percent organic solvent to the aqueous mobile phase.

Prevent Blocking of Solvent Filters

Contaminated solvents or algae growth in the solvent bottle will reduce the lifetime of the solvent filter and will influence the performance of the module. This is especially true for aqueous solvents or phosphate buffers (pH 4 to 7). The following suggestions will prolong lifetime of the solvent filter and will maintain the performance of the module.

- Use a sterile, if possible amber, solvent bottle to slow down algae growth.
- Filter solvents through filters or membranes that remove algae.
- Exchange solvents every two days or refilter.
- If the application permits add 0.0001 – 0.001 M sodium azide to the solvent.
- Place a layer of argon on top of your solvent.
- Avoid exposure of the solvent bottle to direct sunlight.

NOTE

Never use the system without solvent filter installed.

Checking the Solvent Filters

The solvent filters are located on the low-pressure side of the binary pump. A blocked filter therefore does not necessarily affect the high pressure readings of the pump. The pressure readings cannot be used to check whether the filters are blocked or not. If the solvent cabinet is placed on top of the binary pump, the filter condition can be checked in the following way:

Remove the solvent inlet tube from the inlet port of the solvent selection valve or the degasser. If the filter is in good condition, the solvent will freely drip out of the solvent tube (due to hydrostatic pressure). If the solvent filter is partly blocked only very little solvent will drip out of the solvent tube.

WARNING

When opening capillary or tube fittings, solvents may leak out.

The handling of toxic and hazardous solvents and reagents can carry health risks.

- Observe appropriate safety procedures (for example, wear goggles, safety gloves and protective clothing) as described in the material handling and safety data sheet supplied by the solvent vendor, especially when toxic or hazardous solvents are used.

3 Using the Pump

Prevent Blocking of Solvent Filters

Cleaning the Solvent Filters

- Remove the blocked solvent filter from the bottle-head assembly and place it in a beaker with concentrated nitric acid (35%) for one hour.
- Thoroughly flush the filter with HPLC-grade water (remove all nitric acid, some capillary columns can be damaged by nitric acid).
- Replace the filter.

NOTE

Never use the system without solvent filter installed.

Normal Phase Applications

Current passive inlet valves and outlet ball valves used with 1260 and 1290 Infinity pumps do not work well with applications using non-polar solvents as for normal phase applications (e.g. hexane, heptane and CO₂). With such applications, pressure drops could be observed. They are a result of particles electrostatically charging up in insulating solvents and sticking to the balls inside the valves, such that the valves do not close properly any more after some time of use (can be hours).

For normal phase applications, a second type of valves is available, which has a design based on the existing one for 1260 and 1290 Infinity valves. These valves use a new material for valve balls, which is a conductive ceramic and replaces non-conductive ruby balls. The balls do not charge up electrostatically and show good performance in normal phase.

The valves are marked with N for non-polar or normal phase.

Agilent recommends using these valves for (and only for) normal phase applications.

No design change has been done for active inlet valves, which have already been used successfully in the past for normal phase applications in 1200 Series and 1260 Infinity binary pumps.

CAUTION

Corrosion of valves

Normal phase balls/valves corrode quickly in aqueous solutions and acids (at or below pH 7).

→ Do not use normal phase valves in applications running with aqueous solutions.

The N-Valves have been tested successfully in using hexane at pressures below 100 bar; heptane can be used as a substitute for neurotoxic hexane.

Seals for Normal Phase Applications

For running normal phase applications on 1200 Infinity Series pumps, yellow PE seals are required, which exist as piston seals and wash seals. Seal wash is very uncommon for normal phase applications (no buffers needed), but wash seals are needed for seal wash pump heads.

1290 Infinity pumps use PE seals by default. In combination with ceramic pistons, PE seals are used for both reversed phase (1200 bar) and normal phase applications.

1260 Infinity pumps use sapphire pistons and black PTFE piston and wash seals by default (600 bar). Such PTFE seals create small wear particles in normal phase applications, which can clog valves and other parts in the flow path.

PE seals have a limited life time when used with normal phase solvents and sapphire pistons. Agilent recommends a maximum pressure of 200 bar for this combination, which shall also be applied for pressure tests.

Choice of Normal Phase Valves and Seals

Table 7 Recommended valves and seals for normal phase applications

	1260 Infinity	1290 Infinity
Inlet valves	1260 Infinity Inlet Valve Type N (G1312-60166)	1290 Infinity Inlet Valve Type N (G4220-60122) 1290 Infinity Quat Inlet Valve Type N (G4204-60122)
Outlet valves	1260 Infinity Outlet Valve Type N/SFC (G1312-60167)	1290 Infinity Outlet Valve Type N (G4220-60128)
Seals	PE seals (pack of 2) (0905-1420) Wash Seal PE (0905-1718)	

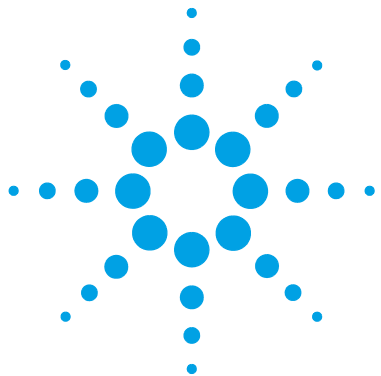

4 Optimizing Performance

When to Use a Vacuum Degasser	60
Operational Hints for the Vacuum Degasser	60
When to Use the Active Seal Wash Option	61
When to Use the Low Volume Mixer	62
When to Remove Damper and Mixer	63
Convert the Binary Pump to Low Delay Volume Mode	64
How to Optimize the Compressibility Compensation Setting	66
Solvent Compressibility Calibration	66
Optimization of Legacy Compressibility Settings	67

This chapter gives information on how to optimize the performance of the Binary Pump under special operational conditions.



When to Use a Vacuum Degasser

A degasser removes air, which is dissolved in any solvent. When solvents are heated or mixed with other solvents, air can leave the solvent and form small bubbles. Over time, these bubbles accumulate and can cause pressure fluctuations which may finally result in retention time shifts.

All Agilent 1200 Infinity II Series Pumps have a built-in degasser. While a degasser is needed for low pressure mixing pumps like Agilent quaternary pumps, high pressure mixing pumps like Agilent binary pumps are more robust with respect to bubble formation. However, a degasser is recommended for best performance.

Additionally, a degasser is highly recommended for the following applications:

- Your detector is used with maximum sensitivity in the low UV wavelength range.
- Your application requires highest injection precision.
- Your application requires highest retention-time reproducibility (flow rates below 0.5 mL/min).
- The binary pump is used with bypassed damper and mixer.

The external 1260 Infinity II Degasser G7122A is recommended for use with applications using highly volatile solvents like Hexane or DCM, solvents with special characteristics like THF, or applications using refractive index detection.

Operational Hints for the Vacuum Degasser

If you are using the vacuum degasser for the first time, if the vacuum degasser was switched off for any length of time (for example, overnight), or if the vacuum degasser chambers are empty, you have to prime the vacuum degasser before running an analysis. Priming is usually done by pumping at a high flow rate (3 – 5 mL/min). Alternatively, a syringe can be used to draw the solvent through the (empty) degasser if the pump does not aspirate the solvent by itself.

When to Use the Active Seal Wash Option

Concentrated buffer solutions will reduce the lifetime of the seals and pistons in your binary pump. The active seal wash option allows to maintain the seal lifetime by flushing the low pressure side of the seals with a wash solvent.

The seal wash option is strongly recommended if buffer concentrations of 0.1 M or higher are used regularly with the pump.

The active seal wash option kit can be ordered by quoting Active Seal Wash Upgrade Product including Service (G1399A).

The seal wash option comprises a peristaltic pump, secondary seals, gaskets, seal holders and tubing for both pump heads. A bottle of premixed water/isopropanol (90/10 vol%) is placed in the solvent cabinet and connected to the peristaltic pump.

Always use a mixture of HPLC-grade water (90 %) and isopropanol (10 %) as wash solvent. This mixture prevents bacteria growth in the wash bottle and reduces the surface tension of the water.

NOTE

In order to avoid accumulation of buffer salts or impurities, regularly replace the washing solution using fresh solvents.

The operation of the peristaltic pump can be controlled from the data system or the Instant Pilot.

For adding a seal-wash option, please contact your local Agilent Technologies service representative.

4 Optimizing Performance

When to Use the Low Volume Mixer

When to Use the Low Volume Mixer

The Low volume mixer (200 μ L) (5067-1565) is designed for use with the Agilent InfinityLab LC Series 1260 Infinity II Binary LC System in low delay volume mode. This configuration is typically used for 2.1 mm i.d., 1.8 μ m particle size columns, where emphasis is put on S/N ratio. The low volume mixer helps mixing gradients starting with a low concentration of organic solvents, which can cause noise on the baseline.

When to Remove Damper and Mixer

The binary pump is equipped with a pressure pulsation damper and a static mixer. The total delay volume of the pump is 600 – 800 μL (depending on system pressure). The mixer has a volume of 400 μL .

For applications that require lowest delay volume (for example, fast gradient methods or gradient applications with low flow rates), damper and mixer can be bypassed.

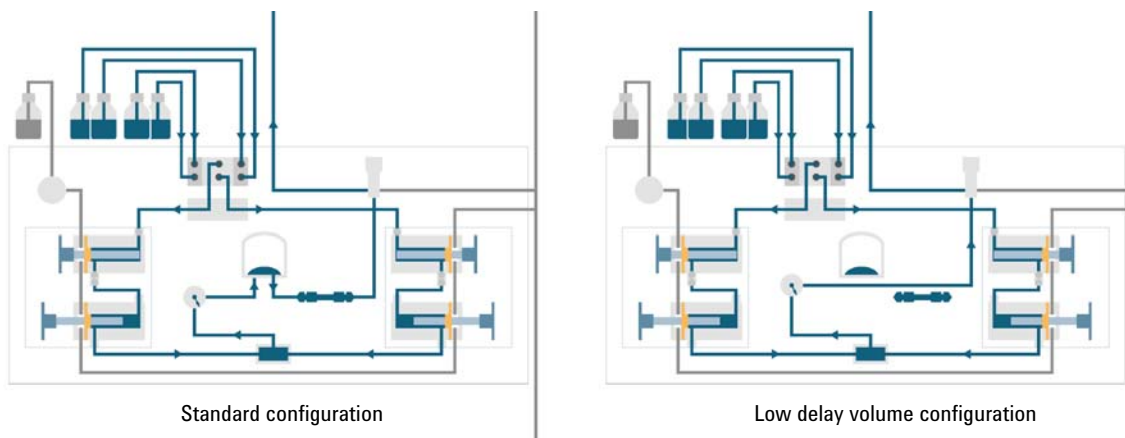

Figure 9 Flow path modifications of the Binary Pump

4 Optimizing Performance

When to Remove Damper and Mixer

Convert the Binary Pump to Low Delay Volume Mode

The binary pump is delivered in standard configuration (damper and mixer connected). This paragraph shows how to bypass damper and mixer and convert the pump to low delay volume mode.

Configurations where only damper or mixer are disconnected while the other part is still in line are not supported by Agilent Technologies.

Tools required	p/n	Description
	8710-0510	Wrench, 1/4 - 5/16 inch, open
		Wrench, 14 mm
		Hex driver open, 1/4 inch

Preparations Flush the system (water if buffers were used, otherwise isopropanol).
Turn the flow off.

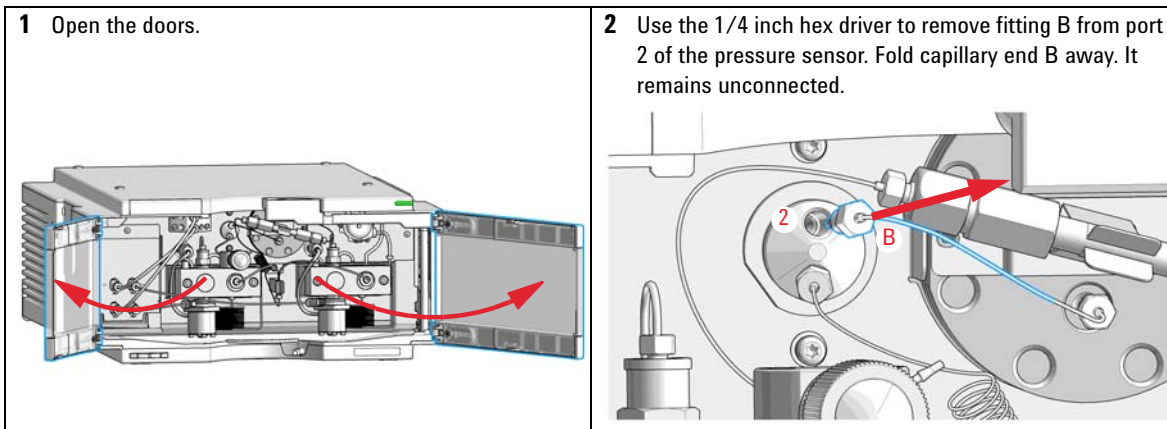

3 Disconnect fitting A from outlet 1 of the mixer.

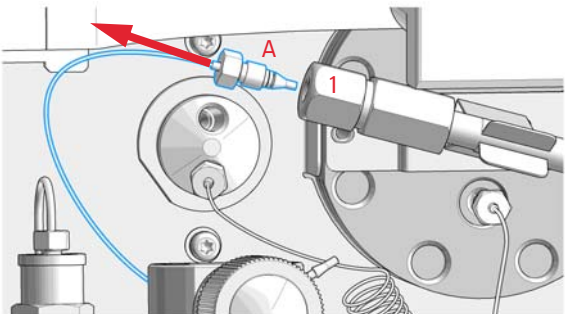

4 Connect fitting A to port 2 of the pressure sensor. Seal port 1 of the mixer with a plastic blank nut.

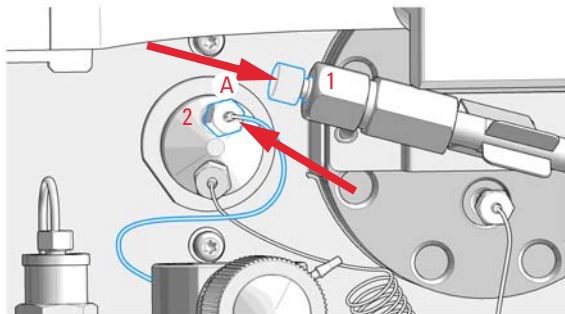

How to Optimize the Compressibility Compensation Setting

When a solvent is metered at ambient pressure and compressed to a higher pressure, the volume decreases depending on its compressibility. Solvent compressibility is a non-linear function of pressure and temperature. It is specific for each solvent.

In order to deliver the desired flow accurately at all pressures, Agilent pumps use a compressibility compensation. For standard LC applications, e.g. using a 400 bar binary pump, an average compressibility value for the solvent is sufficient.

For the 600 bar 1260 Infinity II Binary Pump, the pressure-dependency of a solvent compressibility needs to be considered. It is determined at different pressures between 0 – 600 bar. The pump uses the obtained non-linear function to select the correct compressibility value for the actual pump pressure. Compressibility data for the most common solvents is readily available in the pump firmware.

The compensation algorithm is so powerful that the damper and mixer can be removed from the pump flow path at low flow rate while the pressure ripple and composition ripple remain at low levels.

For method compatibility reasons, the legacy compressibility compensation is still available.

Solvent Compressibility Calibration

Unlisted or premixed solvents can be calibrated with the Solvent Compressibility Calibration function. For a detailed description, see [“Binary Pump Solvent Compressibility Calibration”](#) on page 103.

Optimization of Legacy Compressibility Settings

The compressibility compensation default settings are 50×10^{-6} /bar (best for most aqueous solutions) for pump head A and 115×10^{-6} /bar (to suit organic solvents) for pump head B. The settings represent average values for aqueous solvents (A side) and organic solvents (B side). Therefore it is always recommended to use the aqueous solvent on the A side of the pump and the organic solvent on the B side. Under normal conditions, the default settings reduce the pressure pulsation to below 2 % of system pressure, which is sufficient for most applications. If the compressibility values for the solvents used differ from the default settings, it is recommended to change the compressibility values accordingly. Compressibility settings can be optimized by using the values for various solvents described in [Table 8](#) on page 68. If the solvent in use is not listed in the compressibility table, when using premixed solvents and if the default settings are not sufficient for your application, the following procedure can be used to optimize the compressibility settings:

- 1 Start channel A of the binary pump with the required flow rate.
- 2 Before starting the optimization procedure, the flow must be stable. Use degassed solvent only. Check the tightness of the system with the pressure test (see “(System) Pressure Test” on page 96).
- 3 Your pump must be connected to an Agilent data system or Instant Pilot, the pressure- and %-ripple can be monitored with one of these instruments.
- 4 Start the recording device in plot mode.
- 5 Starting with a compressibility setting of 40×10^{-6} /bar, increase the value in steps of 10. The compressibility compensation setting that generates the smallest pressure ripple is the optimum value for your solvent composition.
- 6 Repeat step 1 through step 5 for the B channel of your binary pump.

4 Optimizing Performance

How to Optimize the Compressibility Compensation Setting

Table 8 Solvent Compressibility

Solvent (pure)	Compressibility (10^{-6} /bar)
Acetone	126
Acetonitrile	115
Benzene	95
Carbon tetrachloride	110
Chloroform	100
Cyclohexane	118
Ethanol	114
Ethyl acetate	104
Heptane	120
Hexane	150
Isobutanol	100
Isopropanol	100
Methanol	120
1-Propanol	100
Toluene	87
Water	46

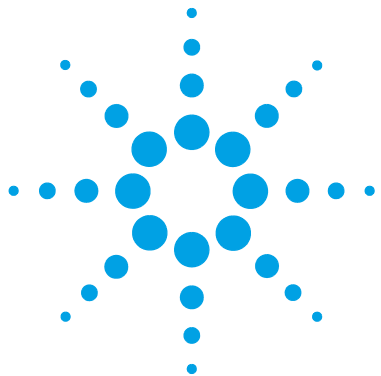

5 Troubleshooting and Diagnostics

Overview of the Module's Indicators and Test Functions 70

User Interfaces 72

Agilent Lab Advisor Software 73

Overview of the troubleshooting and diagnostic features.



Overview of the Module's Indicators and Test Functions

Status Indicators

The module is provided with two status indicators which indicate the operational state of the module. The status indicators provide a quick visual check of the operation of the module.

Error Messages

In the event of an electronic, mechanical or hydraulic failure, the module generates an error message in the user interface. For each message, a short description of the failure, a list of probable causes of the problem, and a list of suggested actions to fix the problem are provided (see chapter Error Information).

Test Functions

A series of test functions are available for troubleshooting and operational verification after exchanging internal components (see Tests and Calibrations).

Pressure Test

The **Pressure Test** is a quick test designed to determine the pressure tightness of the system (i.e. the high pressure flow path between pump and column). After exchanging flow path components (e.g. pump seals or injection seal), use this test to verify the system is pressure tight, see “[\(System\) Pressure Test](#)” on page 96.

Solvent Compressibility Calibration

Solvent compressibility is a function of solvent type and pressure. In order to optimize flow accuracy and pressure ripple, the compressibility of the solvent must be considered. The binary pump firmware contains compressibility parameters for most commonly used solvents. A compressibility calibration function is available to generate compressibility data for unlisted solvents (see [“Binary Pump Solvent Compressibility Calibration”](#) on page 103). The compressibility data are stored in an XML file and can be transferred to other InfinityLab LC Series binary pumps.

Pump Elasticity Calibration

Various parts in the flow path of the binary pump have a certain elasticity which needs to be compensated to obtain the lowest pressure-, flow- and composition ripple possible. This is done by running an elasticity calibration after maintenance and major repairs. For details see [“Pump Elasticity Calibration”](#) on page 105.

Pump Leak Rate Test

The **Pump Leak Rate Test** is a diagnostic test designed to determine the pressure tightness of the pump components. When a problem with the pump is suspected, use this test to help troubleshoot the pump and its pumping performance, see [“Pump Leak Rate Test”](#) on page 107.

User Interfaces

Depending on the user interface, the available tests vary. Some descriptions are only available in the Service Manual.

Test	Instant Pilot G4208A	Agilent Lab Advisor
Pressure Test	Yes	Yes
Valve Test	No	Yes
Solvent compressibility calibration	No	Yes
Pump elasticity calibration	No	Yes

Agilent Lab Advisor Software

The Agilent Lab Advisor Software is a standalone product that can be used with or without a chromatographic data system. Agilent Lab Advisor helps to manage the lab for high-quality chromatographic results by providing a detailed system overview of all connected analytical instruments with instrument status, Early Maintenance Feedback counters (EMF), instrument configuration information, and diagnostic tests. By the push of a button, a detailed diagnostic report can be generated. Upon request, the user can send this report to Agilent for a significantly improved troubleshooting and repair process.

The Agilent Lab Advisor software is available in two versions:

- Lab Advisor Basic
- Lab Advisor Advanced

Lab Advisor Basic is included with every Agilent 1200 Infinity Series and Agilent InfinityLab LC Series instrument.

The Lab Advisor Advanced features can be unlocked by purchasing a license key, and include real-time monitoring of instrument actuals, all various instrument signals, and state machines. In addition, all diagnostic test results, calibration results, and acquired signal data can be uploaded to a shared network folder. The Review Client included in Lab Advisor Advanced allows to load and examine the uploaded data no matter on which instrument it was generated. This makes Data Sharing an ideal tool for internal support groups and users who want to track the instrument history of their analytical systems.

The optional Agilent Maintenance Wizard Add-on provides an easy-to-use, step-by-step multimedia guide for performing preventive maintenance on Agilent 1200 Infinity and Agilent InfinityLab LC Series instrument.

The tests and diagnostic features that are provided by the Agilent Lab Advisor software may differ from the descriptions in this manual. For details, refer to the Agilent Lab Advisor software help files.

5 Troubleshooting and Diagnostics
Agilent Lab Advisor Software

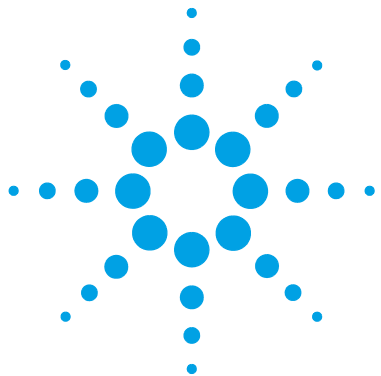

6 Error Information

What Are Error Messages	77
General Error Messages	78
Timeout	78
Shutdown	78
Remote Timeout	79
Lost CAN Partner	79
Leak	80
Leak Sensor Open	81
Leak Sensor Short	81
Compensation Sensor Open	82
Compensation Sensor Short	82
Fan Failed	83
Module Error Messages	84
Solvent Zero Counter	84
Pressure Above Upper Limit	84
Pressure Below Lower Limit	85
Pressure Signal Missing	85
Valve Failed	86
Electronic Fuse of SSV Open	87
AIV Fuse	87
Motor-Drive Power	88
Encoder Missing	89
Servo Restart Failed	90
Pump Head Missing	91
Index Limit	91
Index Adjustment	92
Index Missing	92
Initialization Failed	93



6 Error Information

Agilent Lab Advisor Software

Degasser: signal fail	93
Degasser: Vacuum cannot be maintained	94
Degasser: limit not reached	94

This chapter describes the meaning of error messages, and provides information on probable causes and suggested actions how to recover from error conditions.

What Are Error Messages

Error messages are displayed in the user interface when an electronic, mechanical, or hydraulic (flow path) failure occurs which requires attention before the analysis can be continued (for example, repair, or exchange of consumables is necessary). In the event of such a failure, the red status indicator at the front of the module is switched on, and an entry is written into the module logbook.

If an error occurs outside a method run, other modules will not be informed about this error. If it occurs within a method run, all connected modules will get a notification, all LEDs get red and the run will be stopped. Depending on the module type, this stop is implemented differently. For example, for a pump the flow will be stopped for safety reasons. For a detector, the lamp will stay on in order to avoid equilibration time. Depending on the error type, the next run can only be started, if the error has been resolved, for example liquid from a leak has been dried. Errors for presumably single time events can be recovered by switching on the system in the user interface.

Special handling is done in case of a leak. As a leak is a potential safety issue and may have occurred at a different module from where it has been observed, a leak always causes a shutdown of all modules, even outside a method run.

In all cases, error propagation is done via the CAN bus or via an APG/ERI remote cable (see documentation for the APG/ERI interface).

General Error Messages

Timeout

Error ID: 0062

The timeout threshold was exceeded.

Probable cause

- 1 The analysis was completed successfully, and the timeout function switched off the module as requested.
- 2 A not-ready condition was present during a sequence or multiple-injection run for a period longer than the timeout threshold.

Suggested actions

- Check the logbook for the occurrence and source of a not-ready condition. Restart the analysis where required.
- Check the logbook for the occurrence and source of a not-ready condition. Restart the analysis where required.

Shutdown

Error ID: 0063

An external instrument has generated a shutdown signal on the remote line.

The module continually monitors the remote input connectors for status signals. A LOW signal input on pin 6 of the Enhanced Remote Interface (ERI) connector generates the error message.

Probable cause

- 1 Leak detected in another module with a CAN connection to the system.
- 2 Leak detected in an external instrument with a remote connection to the system.
- 3 Shut-down in an external instrument with a remote connection to the system.
- 4 The degasser failed to generate sufficient vacuum for solvent degassing.

Suggested actions

- Fix the leak in the external instrument before restarting the module.
- Fix the leak in the external instrument before restarting the module.
- Check external instruments for a shut-down condition.
- Check the vacuum degasser for an error condition. Refer to the *Service Manual* for the degasser or the pump that has the degasser built-in.

Remote Timeout

Error ID: 0070

A not-ready condition is still present on the remote input. When an analysis is started, the system expects all not-ready conditions (for example, a not-ready condition during detector balance) to switch to run conditions within one minute of starting the analysis. If a not-ready condition is still present on the remote line after one minute the error message is generated.

Probable cause

- 1 Not-ready condition in one of the instruments connected to the remote line.
- 2 Defective remote cable.
- 3 Defective components in the instrument showing the not-ready condition.

Suggested actions

- Ensure the instrument showing the not-ready condition is installed correctly, and is set up correctly for analysis.
- Exchange the remote cable.
- Check the instrument for defects (refer to the instrument's documentation).

Lost CAN Partner

Error ID: 0071

During an analysis, the internal synchronization or communication between one or more of the modules in the system has failed.

The system processors continually monitor the system configuration. If one or more of the modules is no longer recognized as being connected to the system, the error message is generated.

Probable cause

- 1 CAN cable disconnected.
- 2 Defective CAN cable.
- 3 Defective main board in another module.

Suggested actions

- Ensure all the CAN cables are connected correctly.
 - Ensure all CAN cables are installed correctly.
- Exchange the CAN cable.
- Switch off the system. Restart the system, and determine which module or modules are not recognized by the system.

Leak

Error ID: 0064

A leak was detected in the module.

The signals from the two temperature sensors (leak sensor and board-mounted temperature-compensation sensor) are used by the leak algorithm to determine whether a leak is present. When a leak occurs, the leak sensor is cooled by the solvent. This changes the resistance of the leak sensor which is sensed by the leak-sensor circuit on the main board.

Probable cause	Suggested actions
1 Loose fittings.	Ensure all fittings are tight.
2 Broken capillary.	Exchange defective capillaries.
3 Loose or leaking purge valve, inlet valve, or outlet valve.	Ensure pump components are seated correctly. If there are still signs of a leak, exchange the appropriate seal (purge valve, inlet valve, outlet valve).
4 Loose or leaking purge valve, active inlet valve, or outlet valve.	Ensure pump components are seated correctly. If there are still signs of a leak, exchange the appropriate seal (purge valve, active inlet valve, outlet valve).
5 Defective pump seals.	Exchange the pump seals.

Leak Sensor Open

Error ID: 0083

The leak sensor in the module has failed (open circuit).

The current through the leak sensor is dependent on temperature. A leak is detected when solvent cools the leak sensor, causing the leak-sensor current to change within defined limits. If the current falls outside the lower limit, the error message is generated.

Probable cause	Suggested actions
1 Leak sensor not connected to the Power Switch board.	Please contact your Agilent service representative.
2 Defective leak sensor.	Please contact your Agilent service representative.
3 Leak sensor incorrectly routed, being pinched by a metal component.	Please contact your Agilent service representative.
4 Power switch assembly defective	Please contact your Agilent service representative.

Leak Sensor Short

Error ID: 0082

The leak sensor in the module has failed (short circuit).

The current through the leak sensor is dependent on temperature. A leak is detected when solvent cools the leak sensor, causing the leak sensor current to change within defined limits. If the current increases above the upper limit, the error message is generated.

Probable cause	Suggested actions
1 Defective leak sensor.	Please contact your Agilent service representative.
2 Leak sensor incorrectly routed, being pinched by a metal component.	Please contact your Agilent service representative.
3 Power switch assembly defective	Please contact your Agilent service representative.
4 Cable or contact problem.	Please contact your Agilent service representative.

Compensation Sensor Open

Error ID: 0081

The ambient-compensation sensor (NTC) on the power switch board in the module has failed (open circuit).

The resistance across the temperature compensation sensor (NTC) on the power switch board is dependent on ambient temperature. The change in resistance is used by the leak circuit to compensate for ambient temperature changes. If the resistance across the sensor increases above the upper limit, the error message is generated.

Probable cause

- 1 Loose connection between the power switch board and the main board
- 2 Defective power switch assembly

Suggested actions

- Please contact your Agilent service representative.
- Please contact your Agilent service representative.

Compensation Sensor Short

Error ID: 0080

The ambient-compensation sensor (NTC) on the power switch board in the module has failed (open circuit).

The resistance across the temperature compensation sensor (NTC) on the power switch board is dependent on ambient temperature. The change in resistance is used by the leak circuit to compensate for ambient temperature changes. If the resistance across the sensor falls below the lower limit, the error message is generated.

Probable cause

- 1 Defective power switch assembly
- 2 Loose connection between the power switch board and the main board

Suggested actions

- Please contact your Agilent service representative.
- Please contact your Agilent service representative.

Fan Failed

Error ID: 0068

The cooling fan in the module has failed.

The hall sensor on the fan shaft is used by the main board to monitor the fan speed. If the fan speed falls below a certain limit for a certain length of time, the error message is generated.

This limit is given by 2 revolutions/second for longer than 5 seconds.

Depending on the module, assemblies (e.g. the lamp in the detector) are turned off to assure that the module does not overheat inside.

Probable cause

- 1** Fan cable disconnected.
- 2** Defective fan.
- 3** Defective main board.
- 4** Improperly positioned cables or wires obstructing fan blades.

Suggested actions

- Please contact your Agilent service representative.
- Please contact your Agilent service representative.
- Please contact your Agilent service representative.
- Please contact your Agilent service representative.

Module Error Messages

Solvent Zero Counter

Error ID: 2055

The error message is triggered if the remaining volume in a solvent bottle falls below the set limit.

Probable cause

- 1 Volume in bottle below specified volume.
- 2 Incorrect setting.

Suggested actions

Refill bottles and reset solvent counters.

Make sure the set solvent volume matches the actual bottle filling and set the shutoff limit to a reasonable value (e.g. 100 mL for 1 L bottles)

Pressure Above Upper Limit

Error ID: 2014, 2500

The system pressure has exceeded the upper pressure limit.

Probable cause

- 1 Upper pressure limit set too low.
- 2 Blockage in the flowpath (after the pressure sensor).
- 3 Defective pressure sensor.
- 4 Defective main board.

Suggested actions

Ensure the upper pressure limit is set to a value suitable for the analysis.

Check for blockage in the flow path. The following components are particularly subject to blockage: inline filter frit, needle (autosampler), seat capillary (autosampler), sample loop (autosampler), column frits and capillaries with small internal diameters (e.g. 50 μm ID).

Please contact your Agilent service representative.

Please contact your Agilent service representative.

Pressure Below Lower Limit

Error ID: 2015, 2501

The system pressure has fallen below the lower pressure limit.

Probable cause

- 1 Lower pressure limit set too high.
- 2 Air bubbles in the mobile phase.
- 3 Leak.
- 4 Defective pressure sensor.
- 5 Defective main board.

Suggested actions

- Ensure the lower pressure limit is set to a value suitable for the analysis.
- Make sure that the degasser is in flow path and works correctly. Purge the module.
 - Ensure solvent inlet filters are not blocked.
 - Inspect the pump head, capillaries and fittings for signs of a leak.
 - Purge the module. Run a pressure test to determine whether the seals or other module components are defective.
- Please contact your Agilent service representative.
- Please contact your Agilent service representative.

Pressure Signal Missing

Error ID: 2016

The pressure signal is missing.

The pressure signal must be within a specific voltage range. If the pressure signal is missing, the processor detects a voltage of approximately -120 mV across the pressure sensor.

Probable cause

- 1 Pressure sensor disconnected
- 2 Defective pressure sensor

Suggested actions

- Please contact your Agilent service representative.
- Please contact your Agilent service representative.

Valve Failed

Error ID: 2040

Valve 0 Failed: valve A1

Valve 1 Failed: valve A2

Valve 2 Failed: valve B2

Valve 3 Failed: valve B1

One of the solvent selection valves in the module failed to switch correctly.

The processor monitors the valve voltage before and after each switching cycle. If the voltages are outside expected limits, the error message is generated.

Probable cause

- 1** Solvent selection valve disconnected.
- 2** Connection cable (inside instrument) not connected.
- 3** Connection cable (inside instrument) defective.
- 4** Solvent selection valve defective.

Suggested actions

- Please contact your Agilent service representative.
- Please contact your Agilent service representative.
- Please contact your Agilent service representative.
- Exchange the solvent selection valve.

Electronic Fuse of SSV Open

Error ID: 2049

Valve Fuse 0: Channels A1 and A2

Valve Fuse 1: Channels B1 and B2

One of the solvent-selection valves in the module has drawn excessive current causing the selection-valve electronic fuse to open.

Probable cause

- 1 Defective solvent selection valve.
- 2 Defective connection cable (front panel to main board).
- 3 Defective main board.

Suggested actions

- Restart the pump. If the error message appears again, exchange the solvent selection valve.
- Please contact your Agilent service representative.
- Please contact your Agilent service representative.

AIV Fuse

Error ID: 2044

Inlet-Valve Fuse 0: Pump channel A

Inlet-Valve Fuse 1: Pump channel B

One of the active-inlet valves in the module has drawn excessive current causing the inlet-valve electronic fuse to open.

Probable cause

- 1 Defective active inlet valve.
- 2 Defective connection cable (front panel to main board).
- 3 Defective main board.

Suggested actions

- Restart the module. If the error message appears again, exchange the active inlet valve.
- Please contact your Agilent service representative.
- Please contact your Agilent service representative.

Motor-Drive Power

Error ID: 2041, 2042

Motor-Drive Power: Pump channel A

B: Motor-Drive Power: Pump channel B

The current drawn by the pump motor exceeded the maximum limit.

Blockages in the flow path are usually detected by the pressure sensor, which result in the pump switching off when the upper pressure limit is exceeded. If a blockage occurs before the pressure sensor, the pressure increase cannot be detected and the module will continue to pump. As pressure increases, the pump drive draws more current. When the current reaches the maximum limit, the module is switched off, and the error message is generated.

Probable cause	Suggested actions
1 Flow path blockage in front of the pressure sensor.	Ensure the capillaries and frits between the pump head and pressure sensor inlet are free from blockage.
2 Blocked (passive or active) inlet valve.	Exchange the (passive or active) inlet valve.
3 Blocked outlet valve.	Exchange the outlet valve.
4 High friction (partial mechanical blockage) in the pump drive assembly.	Remove the pump-head assembly. Ensure there is no mechanical blockage of the pump-head assembly or pump drive assembly.
5 Defective pump drive assembly.	Please contact your Agilent service representative.
6 Defective main board.	Please contact your Agilent service representative.
7 Restriction capillary blocked at pre-mixing union.	Exchange restriction capillary.

Encoder Missing

Error ID: 2046, 2050, 2510

Encoder Missing: Pump channel A

B: Encoder Missing: Pump channel B

The optical encoder on the pump motor in the module is missing or defective.

The processor checks the presence of the pump encoder connector every 2 s. If the connector is not detected by the processor, the error message is generated.

Probable cause

- 1 Defective or disconnected pump encoder connector.
- 2 Defective pump drive assembly.

Suggested actions

- Please contact your Agilent service representative.
- Please contact your Agilent service representative.

Servo Restart Failed

Error ID: 2201, 2211

Servo Restart Failed: Pump channel A

B: Servo Restart Failed: Pump channel B

The pump motor in the module was unable to move into the correct position for restarting.

When the module is switched on, the first step is to switch on the C phase of the variable reluctance motor. The rotor should move to one of the C positions. The C position is required for the servo to be able to take control of the phase sequencing with the commutator. If the rotor is unable to move, or if the C position cannot be reached, the error message is generated.

Probable cause

- 1 Mechanical blockage of the module.
- 2 Disconnected or defective cable.
- 3 Blocked (passive or active) inlet valve.
- 4 Defective pump drive assembly.
- 5 Defective main board.

Suggested actions

- Remove the pump-head assembly. Ensure there is no mechanical blockage of the pump-head assembly or pump drive assembly.
- Please contact your Agilent service representative.
- Exchange the (passive or active) inlet valve.
- Please contact your Agilent service representative.
- Please contact your Agilent service representative.

Pump Head Missing

Error ID: 2202, 2212

Pump Head Missing: Pump channel A

B: Pump Head Missing: Pump channel B

The pump-head end stop in the pump was not found.

When the pump restarts, the metering drive moves forward to the mechanical end stop. Normally, the end stop is reached within 20 s, indicated by an increase in motor current. If the end point is not found within 20 s, the error message is generated.

Probable cause

- 1 Pump head not installed correctly (screws not secured, or pump head not seated correctly).
- 2 Broken piston.

Suggested actions

- Install the pump head correctly. Ensure nothing (e.g. capillary) is trapped between the pump head and body.
- Exchange the piston.

Index Limit

Error ID: 2203, 2213

Index Limit: Pump channel A

B: Index Limit: Pump channel B

The time required by the piston to reach the encoder index position was too short (pump).

During initialization, the first piston is moved to the mechanical stop. After reaching the mechanical stop, the piston reverses direction until the encoder index position is reached. If the index position is reached too fast, the error message is generated.

Probable cause

- 1 Irregular or sticking drive movement.
- 2 Defective pump drive assembly.

Suggested actions

- Remove the pump head, and examine the seals, pistons, and internal components for signs of wear, contamination or damage. Exchange components as required.
- Please contact your Agilent service representative.

Index Adjustment

Error ID: 2204, 2214

Index Adjustment: Pump channel A

B: Index Adjustment: Pump channel B

The encoder index position in the module is out of adjustment.

During initialization, the first piston is moved to the mechanical stop. After reaching the mechanical stop, the piston reverses direction until the encoder index position is reached. If the time to reach the index position is too long, the error message is generated.

Probable cause

- 1 Irregular or sticking drive movement.
- 2 Defective pump drive assembly.

Suggested actions

- Remove the pump head, and examine the seals, pistons, and internal components for signs of wear, contamination or damage. Exchange components as required.
- Please contact your Agilent service representative.

Index Missing

Error ID: 2205, 2215, 2505

Index Missing: Pump channel A

B: Index Missing: Pump channel B

The encoder index position in the module was not found during initialization.

During initialization, the first piston is moved to the mechanical stop. After reaching the mechanical stop, the piston reverses direction until the encoder index position is reached. If the index position is not recognized within a defined time, the error message is generated.

Probable cause

- 1 Disconnected or defective encoder cable.
- 2 Defective pump drive assembly.

Suggested actions

- Please contact your Agilent service representative.
- Please contact your Agilent service representative.

Initialization Failed

Error ID: 2207, 2217

Initialization Failed: Pump channel A

B: Initialization Failed: Pump channel B

The module failed to initialize successfully within the maximum time window.

A maximum time is assigned for the complete pump-initialization cycle. If the time is exceeded before initialization is complete, the error message is generated.

Probable cause

- 1 Blocked (passive or active) inlet valve.
- 2 Defective pump drive assembly.
- 3 Defective main board.

Suggested actions

- Exchange the (passive or active) inlet valve.
- Please contact your Agilent service representative.
- Please contact your Agilent service representative.

Degasser: signal fail

Error ID: 2243, 8016

The pump board gets no or wrong pressure signals from the built-in degasser:

- No valid pressure signal is shown during startup of the degasser
- Measured pressure is higher than 32000 hPa

Probable cause

- 1 Degasser sensor defect
- 2 Degasser sensor not connected to main board.

Suggested actions

- Please contact your Agilent service representative.
- Please contact your Agilent service representative.

Degasser: Vacuum cannot be maintained

Error ID: 8014

Pressure in degasser vacuum chamber exceeds 180 mbar limit during normal operation.

Probable cause

- 1 Liquid in degasser tubing.
- 2 Leak in degasser tubing or chamber.
- 3 Degasser vacuum pump defective.

Suggested actions

- Please contact your Agilent service representative.
- Please contact your Agilent service representative.
- Please contact your Agilent service representative.

Degasser: limit not reached

Error ID: 2244, 8053

Degasser is not ready within 8 min after startup, because the pressure inside the vacuum chamber exceeds 120 mbar.

Probable cause

- 1 Liquid in degasser tubing.
- 2 Leak in degasser tubing or chamber.
- 3 Degasser vacuum pump defect.

Suggested actions

- Please contact your Agilent service representative.
- Please contact your Agilent service representative.
- Please contact your Agilent service representative.

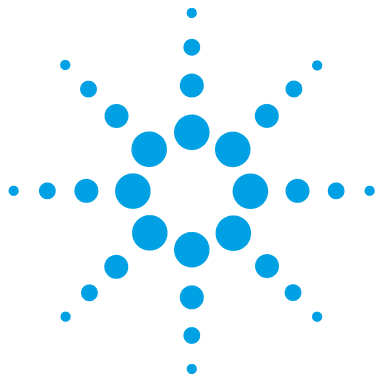

7 Test Functions and Calibration

(System) Pressure Test	96
Positioning the Blank Nut	97
Running the System Pressure Test	98
Evaluating the Results	98
Valve Test	101
Running the Valve Test	102
Evaluating the Results	102
Binary Pump Solvent Compressibility Calibration	103
Running the Solvent Compressibility Calibration	104
Pump Elasticity Calibration	105
Running the Pump Elasticity Calibration	106
Pump Leak Rate Test	107
Running the Test	107
Evaluating the Results	108
Potential Causes of Leak Rate Test Failure	109

This chapter explains all test functions that are available for the binary pump.



(System) Pressure Test

NOTE

This Lab Advisor test uses different names depending on the firmware revision used: FW revision \geq A.06.50: **System Pressure Test**

Description

The system pressure test is a quick built-in test designed to demonstrate the leak tightness of the system. The test involves monitoring the flow profile while the pump delivers against a blank nut. The result is presented as the leak rate of the module and provides information about the leak tightness of the system between the outlet valves of the pump and the blank nut.

NOTE

The blank nut can be positioned anywhere between the purge valve of the pump and the detector inlet to pressure test the desired part of the system.

CAUTION

Blank nut placed at the outlet of flow cell

The applied pressure may cause permanent leaks or bursting of the flow cell.

→ Never include the flow cell in the pressure test.

Step 1

The test begins with the initialization of both pump heads. After initialization, the pump is starting the compression phase and the required flow rate is constantly monitored and adjusted. The pump continues to pump until a system pressure of around 600 bar is reached.

Step 2

When the system pressure reaches 600 bar, the pump continues to pump at a flow rate that keeps the pressure constant. The flow that is needed to keep the pressure constant is directly translated into a leak rate.

Positioning the Blank Nut

To test the complete system's pressure tightness, the blank nut should be positioned at the column compartment outlet (or the outlet of the last module before the detector).

If a specific component is suspected of causing a system leak, place the blank nut immediately before the suspected component, and then run the **System Pressure Test** again. If the test passes, the defective component is located after the blank nut. Confirm the diagnosis by placing the blank nut immediately after the suspected component. The diagnosis is confirmed if the test fails.

Running the System Pressure Test

Running the test from the Agilent Lab Advisor

When The test should be used when problems with small leaks are suspected, or after maintenance of flow path components (e.g., pump seals, injection seal) to prove pressure tightness up to 600 bar

Parts required	p/n	Description
	5043-0277	Plug Black Long 10-32

Preparations Place two bottles of HPLC-grade water in channels A and B (A1 and B1 if the pump is equipped with a solvent selection valve)

NOTE

Make absolutely sure that all parts of the flow path that are part of the test are very thoroughly flushed with water before starting to pressurize the system! Any trace of other solvents or the smallest air bubble inside the flow path definitely will cause the test to fail!

- 1 Select the system pressure test from the test selection menu.
- 2 Start the test and follow the instructions.

NOTE

Make sure to release the pressure by opening the purge valve when the test has completed. Otherwise the pump may generate an overpressure error.

Evaluating the Results

The sum of all leaks between the pump and the blank nut will add up to the total leak rate. Note that small leaks may cause the test to fail, but solvent may not be seen leaking from a module.

NOTE

Please notice the difference between an *error* in the test and a *failure* of the test! An *error* is caused by the abnormal termination during the operation of the test whereas a *failure* of a test indicates that the test results were not within the specified limits.

If the pressure test fails:

- Ensure all fittings between the pump and the blank nut are tight. Repeat the pressure test.

NOTE

Often it is only a damaged blank nut itself (poorly shaped from overtightening) that causes the test to fail. Before investigating on any other possible sources of failure make sure that the blank nut you are using is in good condition and properly tightened!

- If the test fails again, insert the blank nut at the outlet of the previous module in the stack (e.g. autosampler, port 6 of the injection valve), and repeat the pressure test. Exclude each module one by one to determine which module is leaking.
- If the pump is determined to be the source of the leak, run the valve test to identify the defective pump component.

Potential Causes of Pressure Test Failure

After isolating and fixing the cause of the leak, repeat the pressure test to confirm the system is pressure tight.

Table 9 Potential Cause (Pump)

Potential Cause (Pump)	Corrective Action
Purge valve open.	Close the purge valve.
Loose or leaky fitting.	Tighten the fitting or exchange the capillary.
Damaged pump seals or pistons.	Run the valve test to identify the defective component.
Loose purge valve.	Tighten the purge valve nut (14 mm wrench).

7 Test Functions and Calibration

(System) Pressure Test

Table 10 Potential Cause (Autosampler)

Potential Cause (Autosampler)	Corrective Action
Loose or leaky fitting.	Tighten or exchange the fitting or capillary.
Rotor seal (injection valve).	Exchange the rotor seal.
Damaged metering seal or piston.	Exchange the metering seal. Check the piston for scratches. Exchange the piston if required.
Needle seat.	Exchange the needle seat.

Table 11 Potential Cause (Column Compartment)

Potential Cause (Column Compartment)	Corrective Action
Loose or leaky fitting.	Tighten or exchange the fitting or capillary.
Rotor seal (column switching valve).	Exchange the rotor seal.

Valve Test

Description

The **Valve Test** provides a fast and accurate way to verify proper hydraulic operation of the binary pump. Problems that are related to defective valves, seals or pistons can be diagnosed and usually the defective part is identified.

Step 1

The system is setup with water on both channels and a restriction capillary is attached to the outlet of the pump. Pump head A is delivering at 1 mL/min. The pressure signal is monitored and overlaid with the piston movement plot. The pressure pattern and the slope of the pressure signal are evaluated for the delivery strokes of both pistons.

Step 2

The procedure from step 1 is repeated on pump head B.

Step 3

The data from step 1 and 2 are evaluated. In case test failed, a conclusion about the defective part is made.

Running the Valve Test

Running the test from the Agilent Lab Advisor

When The test should be used to prove proper operation of the binary pump after repairs or when the pressure test (see “(System) Pressure Test” on page 96) determined a problem with the pump.

Tools required	p/n	Description
	8710-0510	Wrench, 1/4 - 5/16 inch, open

Parts required	p/n	Description
	G1312-67500	Calibration capillary assembly

Preparations Place two bottles of HPLC-grade water in channels A and B (A1 and B1 if the pump is equipped with a solvent selection valve)

NOTE

The **Valve Test** should only be performed when firmware revisions < A.06.50 are installed. For firmware revision A.06.50 or above, perform the **Leak Rate Test** instead.

NOTE

Make absolutely sure that the pump is very thoroughly flushed with water before starting the test! Any trace of other solvents or the smallest air bubble inside the flow path definitely will cause the test to generate misleading results!

- 1 Select the valve test from the test selection menu.
- 2 Start the test and follow the instructions.

NOTE

Make sure to release the pressure by opening the purge valve when the test has completed. Otherwise the pump may generate an overpressure error.

Evaluating the Results

Refer to the help file of the Agilent Lab Advisor for further details.

Binary Pump Solvent Compressibility Calibration

Description

Each solvent or solvent mixture has unique compressibility at different pressures. In order to deliver accurate flow with minimal pressure- and composition ripple over the full operational pressure range, it is necessary that the pump compensates precisely for the compressibility of the solvents in use.

The binary pump comes with compressibility parameters for the most common HPLC solvents and solvent mixtures. If a solvent is not available in the list of pre-calibrated solvents, the solvent compressibility calibration allows the appropriate compressibility data to be generated.

Technical background

The solvent compressibility calibration relies on an accurate elasticity calibration of the pump. With a proper elasticity calibration in place, the pump is switched into pressure control mode. A restriction capillary is connected to the purge valve outlet. By varying the flow rate, the pump maintains a certain pressure. The pump optimizes the compressibility value of the solvent until the lowest possible pump ripple is reached. The pump increases the flow rate and adjusts the pressure to the next calibration step where the pump ripple is minimized again. This process is repeated until solvent compressibility data for the whole operating pressure range of the pump are available.

The compressibility data set for this solvent is stored in an XML-file on the desktop. It can be shared with other InfinityLab LC Series binary pumps via the controlling data system.

Running the Solvent Compressibility Calibration

Running the Solvent Compressibility Calibration from the Agilent Lab Advisor

When	If a solvent is not available in the list of pre-calibrated solvents, the solvent compressibility calibration allows to generate appropriate compressibility data.	
Tools required	p/n	Description
	8710-0510	Wrench, 1/4 - 5/16 inch, open
Parts required	p/n	Description
	G1312-67500	Calibration capillary assembly
Preparations	Place a bottles with solvent to be calibrated in channel A (resp. A1 if a solvent selection valve is installed).	

CAUTION

Avoid inaccurate pump elasticity calibration.

This would lead into invalid and not-portable solvent compressibility data.

→ Make sure to perform accurate pump elasticity calibration.

NOTE

Make absolutely sure that the pump is very thoroughly flushed with the solvent to be calibrated before starting the procedure! Any trace of other solvents or the smallest air bubble inside the flow path definitely will cause the calibration to fail!

- 1 Select the solvent from the test selection menu.
- 2 Start the test and follow the instructions.

NOTE

Make sure to release the pressure by opening the purge valve when the test has completed. Otherwise the pump may generate an overpressure error.

Pump Elasticity Calibration

Description

The flow path components of the binary pump have an inherent and pressure dependent elasticity which differs from pump to pump. When this elasticity/pressure function is known, a correction algorithm can be applied. This results in significantly improved pump performance in low delay volume mode (damper and mixer bypassed).

The pump elasticity calibration uses a solvent with well known properties (HPLC-grade water) to determine the pump elasticity over the entire operating pressure range and stores the calibration values in the non-volatile RAM of the pump mainboard.

The initial calibration is done at the factory. It only needs to be repeated after replacement of major pump parts (mainboard, pump drive). The test allows to define which pump head will be calibrated.

NOTE

Results of the pump elasticity calibration rely on known compressibility parameters for pure water. If the water is not HPLC-grade, not well degassed or degasser and pump are not flushed properly, the pump elasticity calibration will fail. The pump elasticity calibration has to be performed for each pump head individually.

CAUTION

Incorrect pump elasticity calibration.

Solvent compressibility calibrations acquired with a miscalibrated pump will work, but they are not transferable to other pumps. A correct pump elasticity calibration is an essential prerequisite for successful solvent compressibility calibrations.

→ Calibrate the pump elasticity correctly.

Running the Pump Elasticity Calibration

Running the Pump Elasticity Calibration from the Agilent Lab Advisor Software

When The initial calibration is done at the factory. It only needs to be repeated after replacement of major pump parts (mainboard, pump drive).

Tools required	p/n	Description
	8710-0510	Wrench, 1/4 - 5/16 inch, open

Parts required	p/n	Description
	G1312-67500	Calibration capillary assembly

Preparations Place all bottle heads in to a bottle of HPLC-grade water.

NOTE

Make absolutely sure that the pump is very thoroughly flushed with the solvent to be calibrated before starting the procedure! Any trace of other solvents or the smallest air bubble inside the flow path definitely will cause the calibration to fail!

NOTE

If a solvent selection valve is installed flush all four solvent channels to avoid that air from a dry solvent intake tube is drawn into the flow path upon initialization.

- 1 Select the pump elasticity calibration from the test selection menu.
- 2 Start the test and follow the instructions.

NOTE

Make sure to release the pressure by opening the purge valve when the test has completed. Otherwise the pump may generate an overpressure error.

Pump Leak Rate Test

Introduction

The **Pump Leak Rate Test** is used for verifying the internal tightness of the pump and helps identifying parts which may have caused a leak.

Minimum firmware revisions:

- D.07.01

Running the Test

Parts required	p/n	Description
	5043-0277	Plug Black Long 10-32

- 1 Select the **Pump Leak Rate Test** from the **Test Selection** menu.
- 2 Start the test and follow the instructions.

NOTE

Make sure to release the pressure by slowly opening the purge valve when the test has finished.

Evaluating the Results

Results of the leak rate test are the leak rates measured for pistons 1 and 2 as described for the test principle. If any of the leak rates exceeds 3 $\mu\text{L}/\text{min}$, the test will fail.

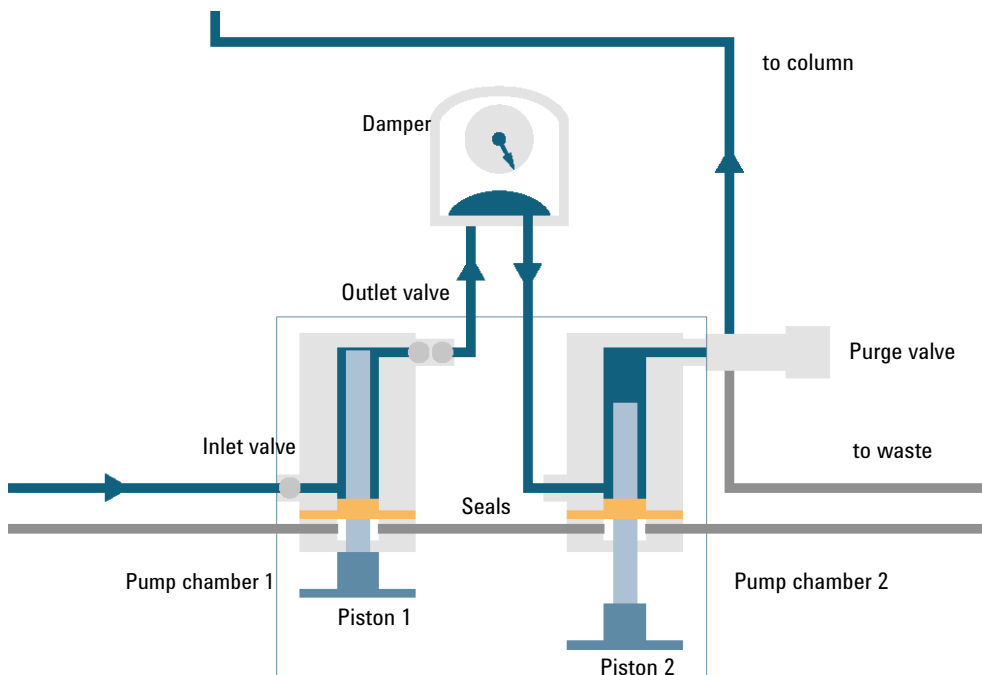

Potential Causes of Leak Rate Test Failure

NOTE

For binary pumps, secondary pump chambers are connected. A leak observed in any of these chambers may be caused by the other secondary pump chamber.

Secondary Leak

If a leak is found for movement of piston 2 (secondary leak), the following reasons are possible:

Probable cause	Suggested actions
1 System not flushed properly	Flush system for several minutes
2 Degassing efficiency is low	Check degasser performance
3 Purge valve not closed or defect	Check purge valve
4 Blank nut not installed tightly	Tighten or replace blank nut
5 Outlet valve leaking (read below)	Replace outlet valve
6 Leak at piston 2 or seal in chamber 2	Inspect piston, replace piston and/or seal

Primary Leak

If a leak is found for movement of piston 1 (primary leak), any leak described for piston movement 2 will cause a failure for piston 1 as well, as the liquid can move through the outlet valve to chamber 2. Such cases need to be identified as described before. Additionally, following causes are possible:

Probable cause	Suggested actions
1 Leak at piston 1 or seal in chamber 1	Inspect piston, replace piston and/or seal
2 Leak at inlet valve	Replace inlet valve or inlet valve cartridge (AIV only)

7 Test Functions and Calibration

Pump Leak Rate Test

Internal Outlet Valve Leak

A leak of the outlet valve will be identified separately (internal outlet valve leak) by calculating the difference between leak rate 1 and leak rate 2. If the second leak rate is higher than the first one, this is due to a flow back through the outlet valve.

Probable cause

- 1 Leak at outlet valve

Suggested actions

Replace the part which has failed and re-run the test.

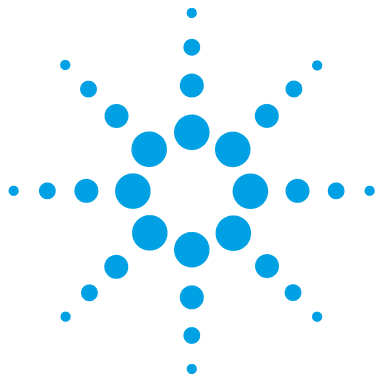

8 Maintenance

Introduction to Maintenance	112
Cautions and Warnings	113
Cleaning the Module	115
Overview of Maintenance and Simple Repairs	116
Maintenance Procedures	117
Remove and Install Doors	118
Exchange the Purge Valve Frit or the Purge Valve	120
Replace the O-Ring on the Purge Valve	123
Remove the Pump Head Assembly	125
Maintenance of a Pump Head without Seal Wash	127
Maintenance of a Pump Head with Seal Wash	130
Reinstall the Pump Head Assembly	134
Seal Wear-in Procedure	136
Exchange the Active Inlet Valve (AIV) or its Cartridge	137
Exchange the Seal Wash Cartridge	140
Replace Leak Handling System Parts	142
Exchange the Outlet Valve	144
Installation of the Solvent Selection Valve Upgrade Kit	146
Exchange the Solvent Selection Valve	148
Replacing Module Firmware	151

This chapter describes the maintenance of the module.



Introduction to Maintenance

The pump is designed for easy maintenance. The most frequent maintenance procedures such as piston seal replacement and purge valve frit exchange can be done from the front side without removing the pump from the system stack.

These procedures are described in [“Overview of Maintenance and Simple Repairs”](#) on page 116.

Cautions and Warnings

WARNING

The module is partially energized when switched off, as long as the power cord is plugged in.

Repair work at the module can lead to personal injuries, e.g. electrical shock, when the cover is opened and the module is connected to power.

- Always unplug the power cable before opening the cover.
 - Do not connect the power cable to the instrument while the covers are removed.
-

WARNING

Sharp metal edges

Sharp-edged parts of the equipment may cause injuries.

- To prevent personal injury, be careful when getting in contact with sharp metal areas.
-

WARNING

Toxic, flammable and hazardous solvents, samples and reagents

The handling of solvents, samples and reagents can hold health and safety risks.

- When working with these substances observe appropriate safety procedures (for example by wearing goggles, safety gloves and protective clothing) as described in the material handling and safety data sheet supplied by the vendor, and follow good laboratory practice.
 - The volume of substances should be reduced to the minimum required for the analysis.
 - Do not operate the instrument in an explosive atmosphere.
-

8 Maintenance

Cautions and Warnings

CAUTION

Electronic boards and components are sensitive to electrostatic discharge (ESD). ESD can damage electronic boards and components.

- Be sure to hold the board by the edges, and do not touch the electrical components. Always use ESD protection (for example, an ESD wrist strap) when handling electronic boards and components.
-

CAUTION

Safety standards for external equipment

- If you connect external equipment to the instrument, make sure that you only use accessory units tested and approved according to the safety standards appropriate for the type of external equipment.
-

Cleaning the Module

To keep the module case clean, use a soft cloth slightly dampened with water, or a solution of water and mild detergent.

WARNING

Liquid dripping into the electronic compartment of your module can cause shock hazard and damage the module

- Do not use an excessively damp cloth during cleaning.
 - Drain all solvent lines before opening any connections in the flow path.
-

Overview of Maintenance and Simple Repairs

Figure 10 on page 116 shows the main user accessible assemblies of the binary pump. The pump heads and its parts require normal maintenance (for example, seal exchange) and can be accessed from the front (simple repairs). Replacement of valve cartridges or filters don't require to remove the pump from the system stack.

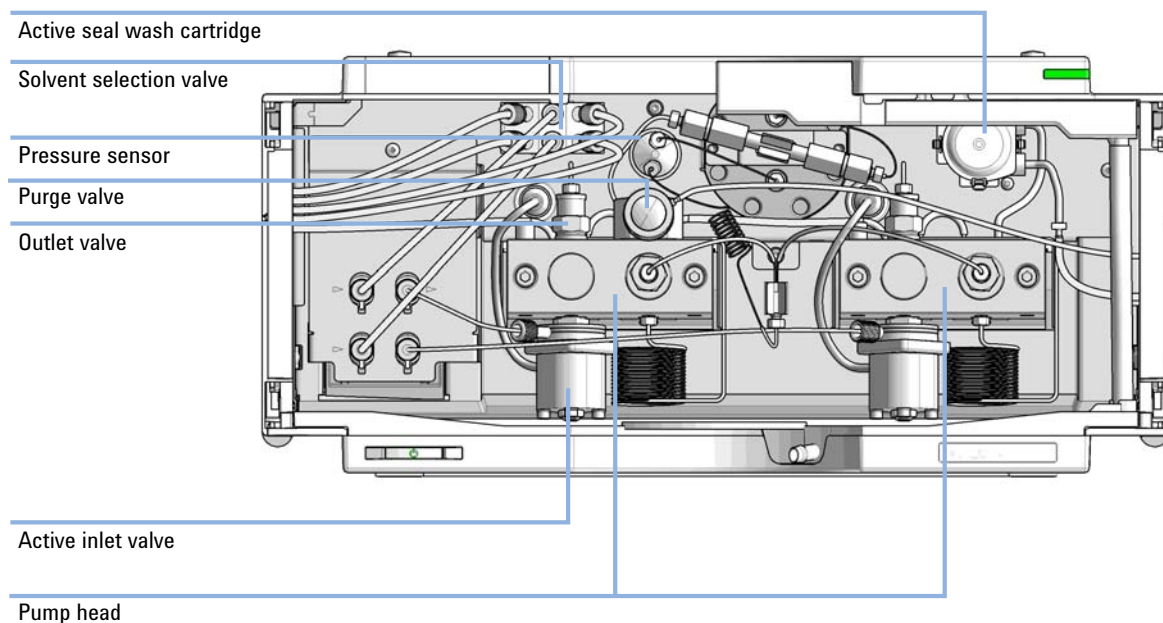

Figure 10 Overview of Maintenance and Simple Repairs

- | | |
|---|--|
| 1 | Purge valve, see “Exchange the Purge Valve Frit or the Purge Valve” on page 120 |
| 2 | Outlet valve, see “Exchange the Outlet Valve” on page 144 |
| 3 | Active inlet valve, see “Exchange the Active Inlet Valve (AIV) or its Cartridge” on page 137 |
| 4 | Pump head, see “Maintenance of a Pump Head with Seal Wash” on page 130 |
| 5 | Solvent selection valve, see “Exchange the Solvent Selection Valve” on page 148 |

Maintenance Procedures

The procedures described in this section can be done with the binary pump in place in the system stack.

Table 12 Maintenance procedures

Procedure	Typical Frequency	Notes
“Exchange the Purge Valve Frit or the Purge Valve” on page 120	Yearly, or if the frit shows indication of contamination or blockage If internally leaking	A pressure drop of > 10 bar in low delay volume configuration and > 20 bar in standard configuration across the frit (5 mL/min H ₂ O with purge valve open) indicates blockage Solvent dripping out of waste outlet when valve is closed
“Remove the Pump Head Assembly” on page 125	During yearly maintenance	Necessary to get access to pump seals and pistons
“Maintenance of a Pump Head without Seal Wash” on page 127	Yearly, or if pump performance indicates seal wear	Leaks at lower pump head side, unstable retention times, pressure ripple unstable — run Pump Leak Rate Test for verification Seal life time shorter than normally expected — check pistons while changing the seals
“Maintenance of a Pump Head with Seal Wash” on page 130	Yearly, or if pump performance indicates seal wear	Only necessary when Seal Wash Option is installed. Leaks at lower pump head side, loss of wash solvent
“Exchange the Active Inlet Valve (AIV) or its Cartridge” on page 137	If leaking externally If solenoid is defective	Error messages “Inlet Valve Fuse” or “Inlet Valve Missing”
“Exchange the Outlet Valve” on page 144	If internally leaking	Pressure ripple unstable, run Pump Leak Rate Test for verification
“Exchange the Solvent Selection Valve” on page 148	If internally leaking If solenoid is defective	Cross port flow Error message “Valve Failed”

Remove and Install Doors

Parts required	p/n	Description
	5067-5746	Door Assembly Infinity 180 Right
	5067-5745	Door Assembly Infinity 180 Left

NOTE

The figures shown in this procedure exemplarily show the Infinity II Multisampler module. The principle of how to remove and/or install doors works in the same way for all Infinity II modules.

1 Press the release buttons and pull the front door out.

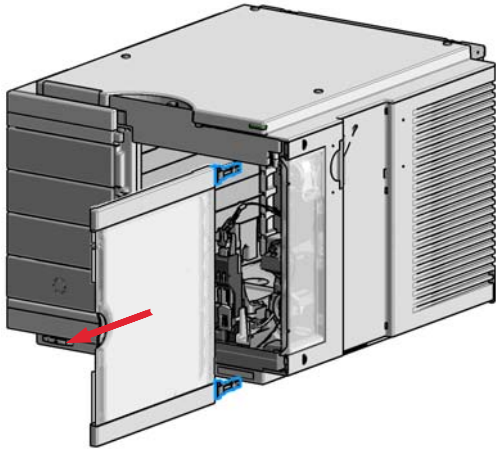
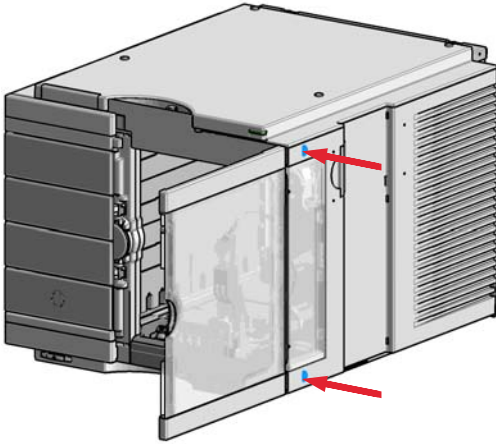

2 For the Installation of the front door. Insert the hinges into their guides and move the door in until the release buttons click into their final position.

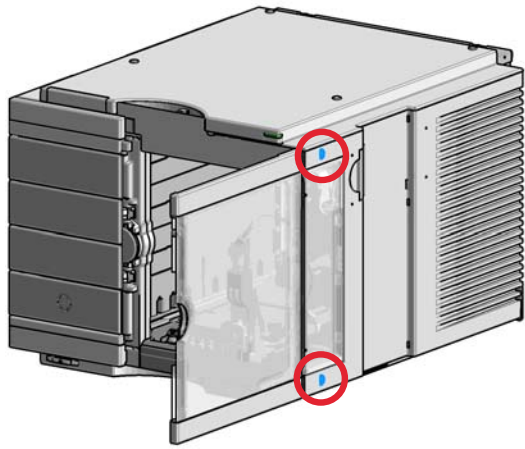
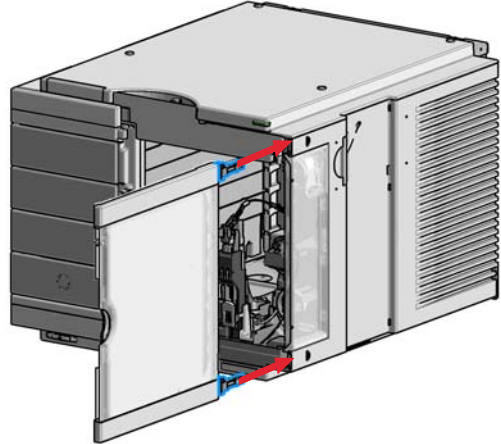

8 Maintenance

Exchange the Purge Valve Frit or the Purge Valve

Exchange the Purge Valve Frit or the Purge Valve

- When**
- Frit – when piston seals are exchanged or when contaminated or blocked (pressure drop of > 10 bar in low delay volume configuration and > 20 bar in standard configuration across the frit at a flow rate of 5 mL/min of water with purge valve opened)
 - Purge valve – if internally leaking

Tools required	p/n	Description
	8710-0510	Open-end wrench 1/4 — 5/16 inch
	8710-1924	Open-end wrench 14 mm
		Pair of tweezers
OR		Toothpick

Parts required	p/n	Description
	01018-22707	PTFE frits (pack of 5)
	G7111-60061	Purge valve
	5067-4728	Seal cap

- Preparations**
- Switch off pump at the main power switch
 - Open the doors
 - Use an optional solvent shutoff valve or lift up solvent filters in solvent reservoirs for avoiding leakages

- 1** Using a 1/4 inch wrench disconnect the pump outlet capillary from the purge valve. Disconnect the waste tube. Beware of leaking solvents due to hydrostatic pressure.

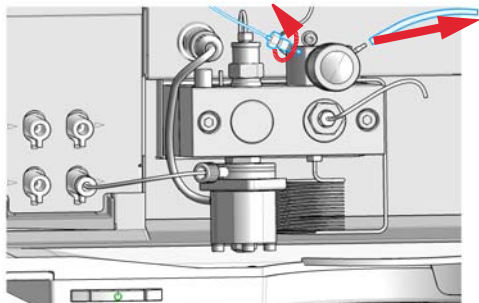

- 2** Using the 14 mm wrench, unscrew the purge valve and remove it from the purge valve holder.

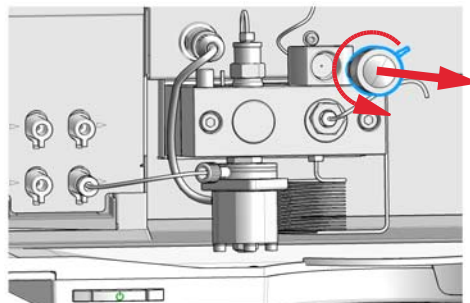

Exchange the Purge Valve Frit or the Purge Valve

3 Remove the seal cap from the purge valve.

Seal cap

Frit

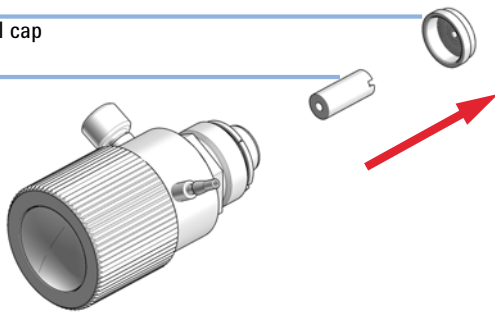

4 Using a pair of tweezers or a toothpick remove the frit.

5 Place a new frit into the purge valve with the orientation of the frit as shown below (slit in frit points to the front).

Seal cap

Frit

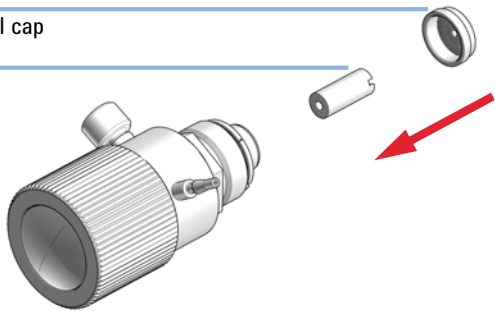

6 Reinstall the seal cap including the gold seal.

NOTE

Before reinstallation always check the gold seal in the seal cap. A deformed seal cap should be exchanged.

8 Maintenance

Exchange the Purge Valve Frit or the Purge Valve

7 Insert the purge valve into the purge valve holder.

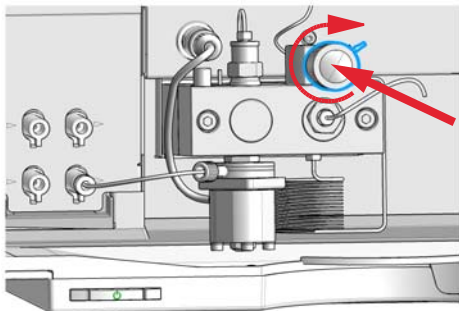

CAUTION

Damage to the purge valve

- Do not lift the pump using the purge valve as a handle, it might get leaky.
- Do not try to turn the purge valve into the correct position when already fixed to the pump. The rubber o-ring might break.
- Anticipate the correct position of the connections before tightening the valve.

8 Tighten the purge valve and reconnect outlet capillary and waste tubing.

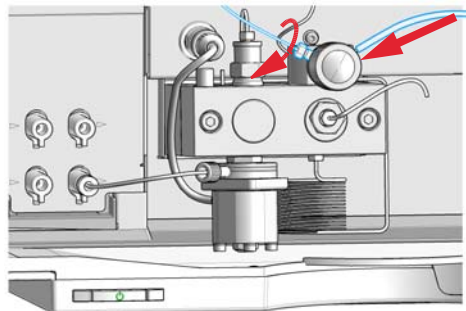

Replace the O-Ring on the Purge Valve

When If the original o-ring is damaged and needs to be replaced

Tools required	p/n	Description
	8710-0510	Open-end wrench 1/4 — 5/16 inch
	8710-1924	Open-end wrench 14 mm
		Pair of tweezers
OR		Toothpick

Parts required	#	p/n	Description
	1	5067-6595	1260 PV O-ring FKM 5/pack
	1	01018-22707	PTFE frits (pack of 5) (OPTIONAL)
	1	5067-4728	Seal cap (OPTIONAL)

- Preparations**
- Switch off pump at the main power switch.
 - Open the doors of the module.
 - Use an optional solvent shutoff valve or lift up solvent filters in solvent reservoirs for avoiding leakages.
 - Remove the purge valve from the pump head.

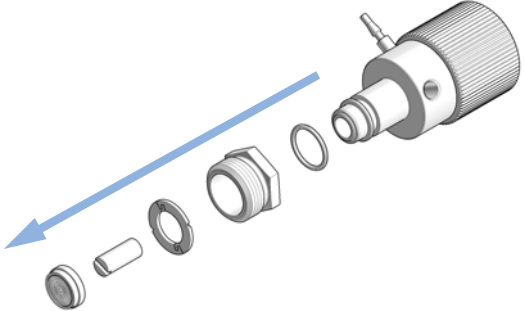
<p>1 Disassemble the purge valve.</p> 	<p>2 Remove the old o-ring from the purge valve.</p> <p>3 Clean the purge valve parts.</p>
--	--

8 Maintenance

Replace the O-Ring on the Purge Valve

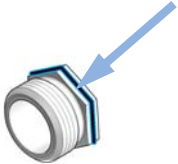
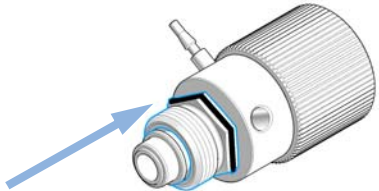
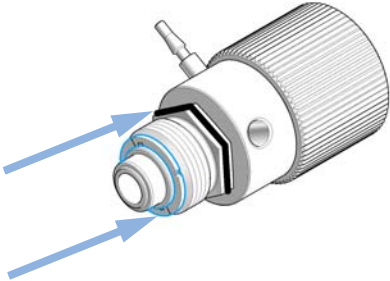
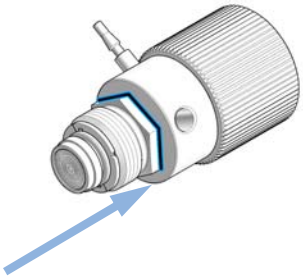
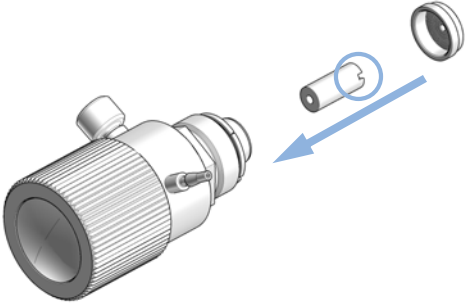
<p>4 Place the new o-ring on the Screw Purge Valve.</p> 	<p>5 Place the screw with o-ring on the Purge Valve Body.</p> 
<p>6 Place the mounting ring on the screw and push down the o-ring.</p> 	<p>7 Push the screw up and guide the o-ring into the gap.</p> 
<p>8 Place a new frit into the purge valve with the orientation of the frit as shown below (slit in frit points to the front). Reinstall the seal cap including the gold seal.</p>  <p>NOTE Before reinstallation always check the gold seal in the seal cap. A deformed seal cap should be exchanged.</p>	<p>9 Install the purge valve to the pump. Make sure not to turn the purge valve body when the screw is fixed to the pump. The o-ring will take damage.</p>

Remove the Pump Head Assembly

- When**
- Exchanging pump seals
 - Exchanging pistons
 - Exchanging seals of the seal wash option

Tools required	p/n	Description
	8710-0510	Open-end wrench 1/4 — 5/16 inch
		Hexagonal key, 4 mm
	5023-0240	Hex driver, ¼", slitted

Preparations Switch off the pump at the main power switch.

CAUTION

Damage of the pump drive

Starting the pump when the pump head is removed may damage the pump drive.

→ Never start the pump when the pump head is removed.

NOTE

Both pump head assemblies use the same internal components. In addition, pump head A is fitted with the purge valve. The following procedure describes the removal and disassembly of pump head A (left). For pump head B (right) proceed in the same way and skip steps that deal with the purge valve.

8 Maintenance

Remove the Pump Head Assembly

1 Open the doors.

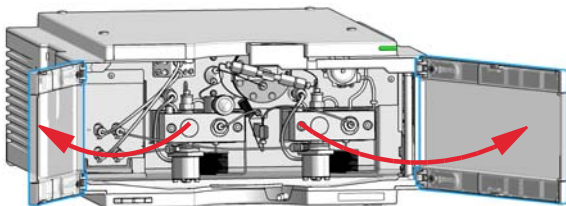

2 Disconnect the capillaries at the back of the purge valve holder, the pump head adapter and the tube at the active inlet valve. Beware of leaking solvents.

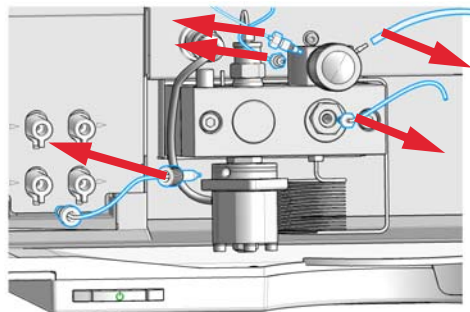

3 Using a 4 mm hexagonal key stepwise loosen and remove the two pump head screws.

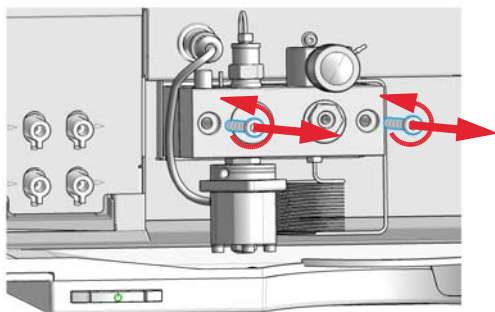

4 Unplug the active inlet valve cable from the connector. Remove the pump head assembly from the module.

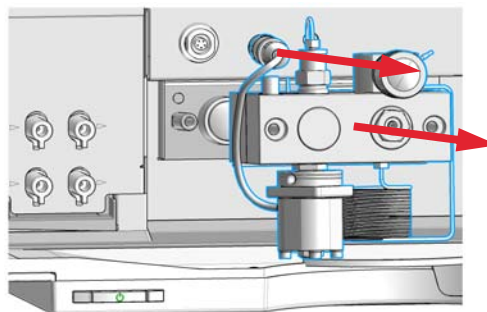

Maintenance of a Pump Head without Seal Wash

When In case of maintenance or pump head internal leaks

Tools required	p/n	Description
	8710-0510	Open-end wrench 1/4 — 5/16 inch
		Hexagonal key, 4 mm
	01018-23702	Insert tool

Parts required	#	p/n	Description
	1	5063-6589	Piston seal PTFE, carbon filled, black (pack of 2), default
OR	1	0905-1420	PE seals (pack of 2)
	1	5063-6586	Sapphire piston

- Preparations**
- Switch off the pump at the main power switch.
 - Open the doors of the module.
 - Use an optional solvent shutoff valve or lift up solvent filters for avoiding leakages.
 - Remove the Pump Head Assembly.

NOTE

Both pump head assemblies use the same internal components. In addition, pump head A is fitted with the purge valve. The following procedure describes the removal and disassembly of pump head A (left). For pump head B (right) proceed in the same way and skip steps that deal with the purge valve.

8 Maintenance

Maintenance of a Pump Head without Seal Wash

- 1** Place the pump head on a flat surface. Loosen the lock screw (two turns).

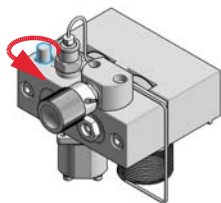

- 2** While holding the lower half of the assembly (piston housing), carefully pull the pump housing away from the piston housing.

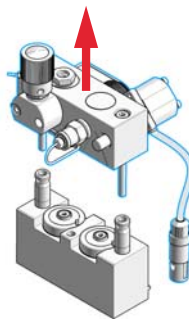

- 3** Remove the support rings from the piston housing.

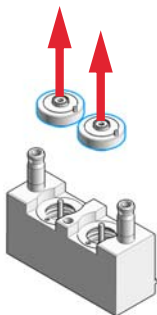

- 4** Lift the housing away from the pistons.

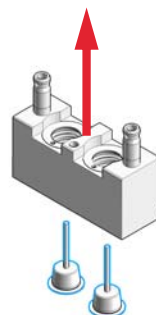

- 5** Check the piston surface and remove any deposits or layers: clean the piston surface with abrasive paper and rinse with 2-propanol. Replace piston if scratched.

Piston Surface

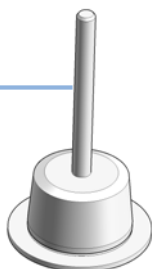

- 6** Using the steel side of the insert tool, carefully remove the seal from the pump housing.

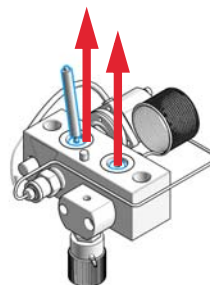

Maintenance of a Pump Head without Seal Wash

- 7** Using the plastic side of the insert tool, insert new seals into the pump head.

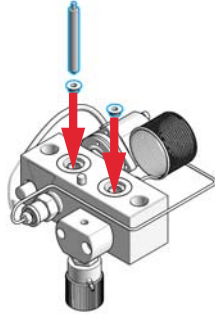

- 8** Place the support rings on the piston housing. Note the correct position of the pins.

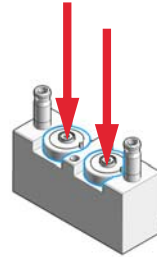

- 9** Place the pump housing onto the piston housing.

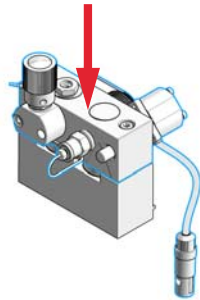

- 10** Insert the pistons and carefully press them into the seals.

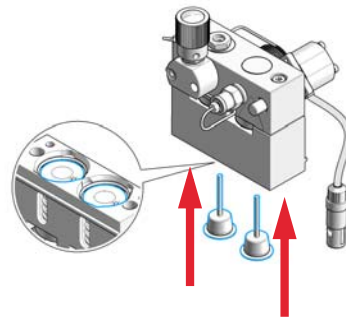

- 11** Tighten the lock screw.

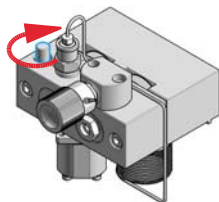

- 12** Install the pump head, see [“Reinstall the Pump Head Assembly”](#) on page 134.

8 Maintenance

Maintenance of a Pump Head with Seal Wash

Maintenance of a Pump Head with Seal Wash

When In case of maintenance or pump head internal leaks

Tools required	p/n	Description
		Hexagonal key, 4 mm
	01018-23702	Insert tool
		Screwdriver, small flat head

Parts required	#	p/n	Description
	1	5063-6589	Piston seal PTFE, carbon filled, black (pack of 2), default
OR	1	0905-1420	PE seals (pack of 2)
	1	5062-2484	Gasket, seal wash (pack of 6)
	1	0905-1175	Wash seal (PTFE)
OR	1	0905-1718	Wash Seal PE
	1	5063-6586	Sapphire piston

- Preparations**
- Switch off the pump at the main power switch.
 - Open the doors of the module.
 - Use an optional solvent shutoff valve or lift up solvent filters for avoiding leakages.
 - Remove the Pump Head Assembly.
 - Remove the wash solvent tubings from the support ring inlet and outlet.

NOTE

Both pump head assemblies use the same internal components. In addition, pump head A is fitted with the purge valve. The following procedure describes the removal and disassembly of pump head A (left). For pump head B (right) proceed in the same way and skip steps that deal with the purge valve.

Maintenance of a Pump Head with Seal Wash

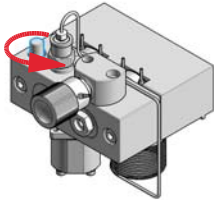
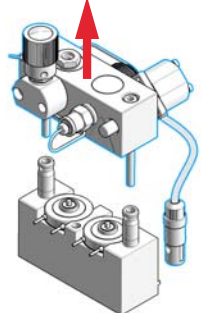
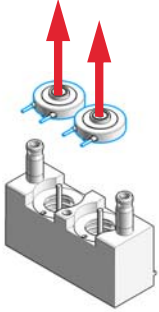
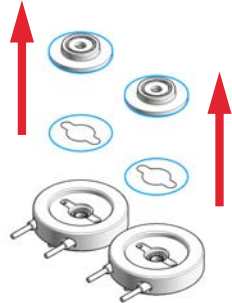
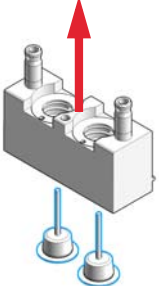
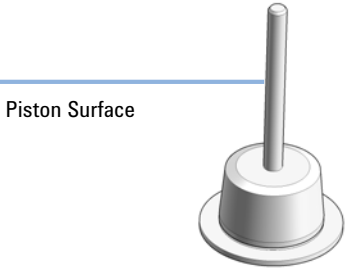
<p>1 Place the pump head on a flat surface. Loosen the lock screw (two turns).</p> 	<p>2 While holding the lower half of the assembly (piston housing), carefully pull the pump housing away from the piston housing.</p> 
<p>3 Remove the seal holder and the seal wash support rings from the piston housing.</p> 	<p>4 Remove the seal holder from the support ring assembly.</p> 
<p>5 Lift the housing away from the pistons.</p> 	<p>6 Check the piston surface and remove any deposits or layers: clean the piston surface with abrasive paper and rinse with 2-propanol. Replace piston if scratched.</p> 

8 Maintenance

Maintenance of a Pump Head with Seal Wash

- 7** Using the steel side of the insert tool, carefully remove the seal from the pump housing.

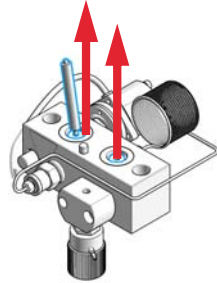

- 8** Using the plastic side of the insert tool, insert new seals into the pump head.

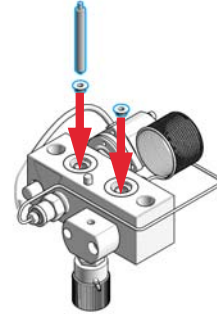

- 9** Using the steel side of the insert tool, remove the seal wash gasket and the wash seal from the support ring.

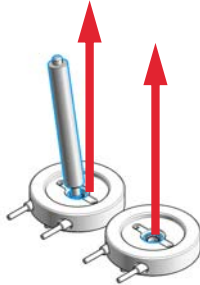

- 10** Using the plastic side of the insert tool, press the new wash seal (spring pointing upwards) into the recess of the support ring.

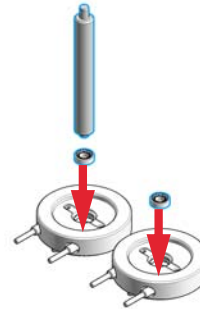

- 11** Place a seal wash gasket in the recess of the support ring. Use a matching orientation of gasket and support ring. Put the seal holder on top of the gasket.

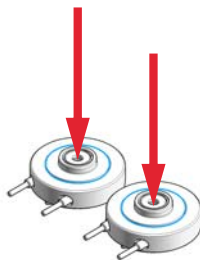

- 12** Place the support rings on the piston housing. Note the correct position of the pins on the support ring.

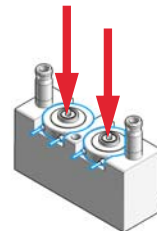

Maintenance of a Pump Head with Seal Wash

13 Place the pump housing onto the piston housing.

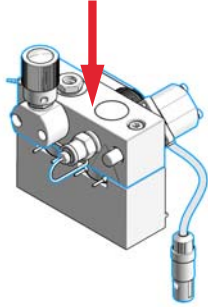

14 Insert the pistons and carefully press them into the seals.

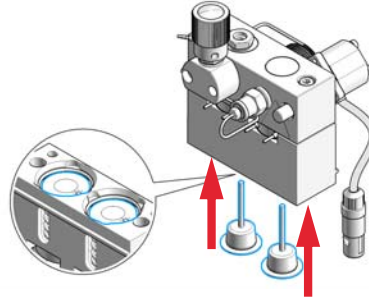

15 Tighten the lock screw.

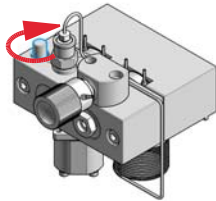

16 Install the pump head, see [“Reinstall the Pump Head Assembly”](#) on page 134.

8 Maintenance

Reinstall the Pump Head Assembly

Reinstall the Pump Head Assembly

When When reassembling the pump

Tools required	p/n	Description
	8710-0510	Open-end wrench 1/4 — 5/16 inch
		Hexagonal key, 4 mm
	5023-0240	Hex driver, ¼", slitted

Parts required	#	p/n	Description
	1	79846-65501	Pump head grease

CAUTION

Damage of the pump drive

Starting the pump when the pump head is removed may damage the pump drive.

→ Never start the pump when the pump head is removed.

- 1** Slide the pump head assembly onto the pump drive. Reconnect the active inlet valve cable to the connector.

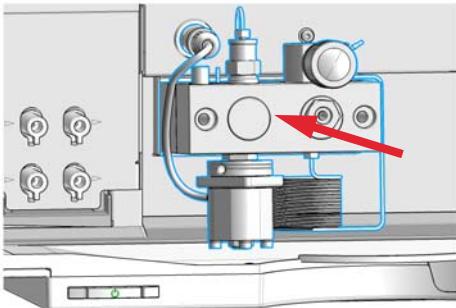

- 2** Using a 4 mm hexagonal key, tighten the pump head screws stepwise with increasing torque.

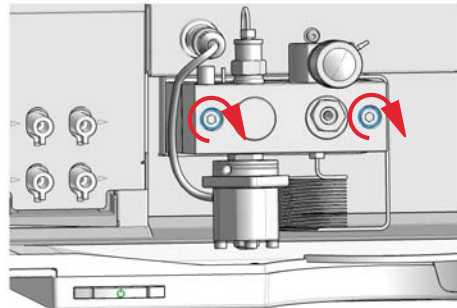

Reinstall the Pump Head Assembly

3 Reconnect all tubings and capillaries.

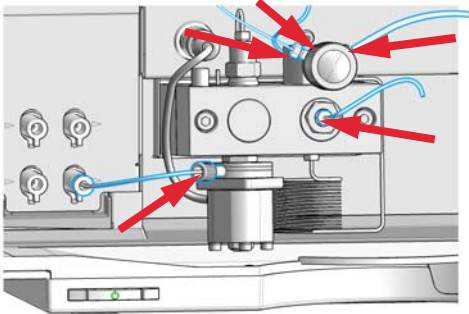

4 Close the doors.

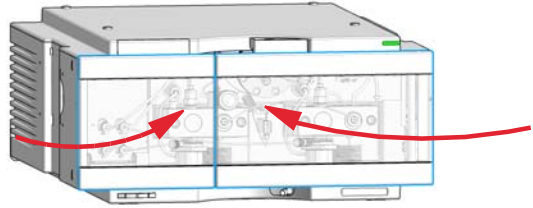

Seal Wear-in Procedure

- 1** Put a bottle with 100 ml of isopropanol in the solvent cabinet and place the solvent intake filter of the pump head you want to wear in into this bottle.
- 2** Screw the PEEK adapter 1/4-28 to 10-32 (0100-1847) onto the active inlet valve and connect the inlet tube from the bottle head directly to it.
- 3** Connect the Restriction capillary (5022-2159) to the purge valve. Connect its other end to a waste container.
- 4** Open the purge valve and purge the system for 5 min with isopropanol at a flow rate of 2 mL/min.
- 5** Close the purge valve, set the flow to a value that gives a pressure of 350 bar. Pump 15 min at this pressure to wear the seals in. The pressure can be monitored with the Instant Pilot, chromatographic data system or any other controlling device connected to your pump.
- 6** Turn OFF the pump, slowly open the purge valve to release the pressure from the system, disconnect the restriction capillary and reconnect the outlet capillary to the purge valve. Reconnect the intake tubing to the solvent selection valve and the connecting tube from the solvent selection valve (if installed) to the AIV.
- 7** Purge your system with the solvent used for your next application.

Exchange the Active Inlet Valve (AIV) or its Cartridge

When	If internally leaking (backflow)	
Tools required	p/n	Description
	8710-1924	Open-end wrench 14 mm
Parts required	p/n	Description
	G1312-60025	Active inlet valve body, without cartridge
	G1312-60020	Cartridge for active inlet valve 600 bar
Preparations	Switch off the pump at the main power switch	

CAUTION

Ensure correct fit of the active inlet valve
Overtightening will destroy the active inlet valve cartridge.

→ Tighten the active inlet valve properly.

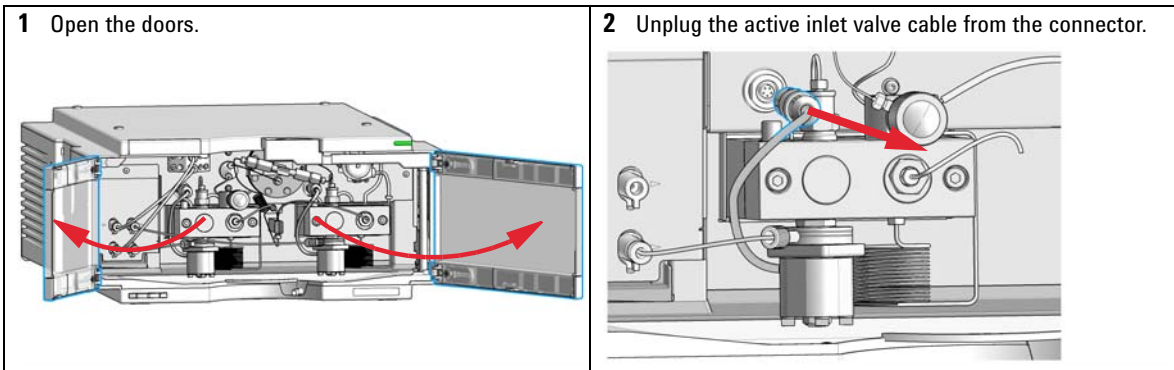

8 Maintenance

Exchange the Active Inlet Valve (AIV) or its Cartridge

- 3** Disconnect the solvent inlet tube at the active inlet valve (beware of leaking solvents).

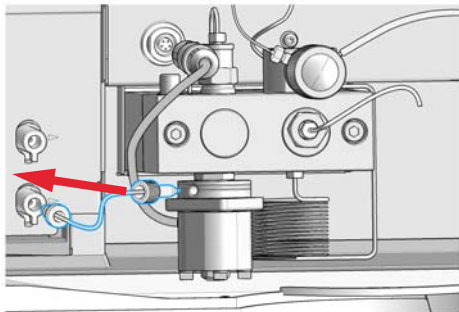

- 4** Using a 14 mm wrench, loosen the active inlet valve and remove the valve from the pump head.

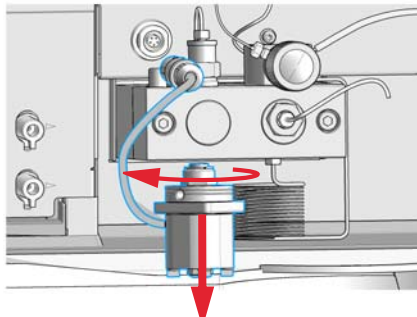

- 5** Using a pair of tweezers, remove the valve cartridge from the defective active inlet valve.

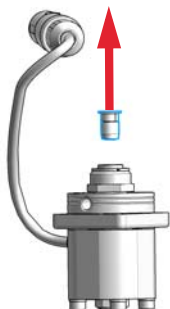

- 6** Push the cartridge into the new active inlet valve.

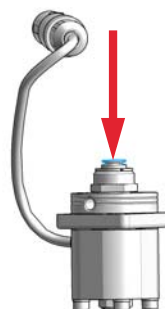

- 7** Screw the new valve into the pump head. With the 14 mm wrench, turn the nut until it is hand tight.

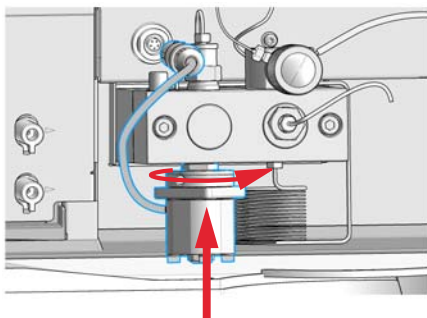

- 8** Position the valve so that the solvent inlet tube connection points towards the front.

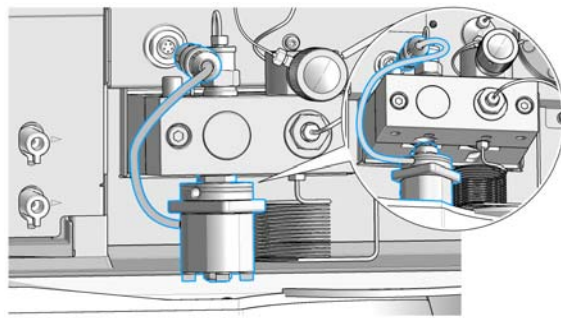

Exchange the Active Inlet Valve (AIV) or its Cartridge

- 9** Using the 14 mm wrench, tighten the nut by turning the valve in its final position (not more than a quarter turn). Do not overtighten the valve.

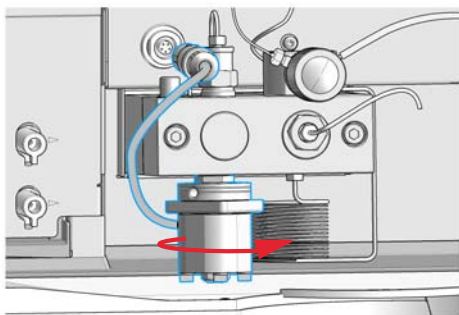

- 10** Reconnect the inlet tube to the valve.

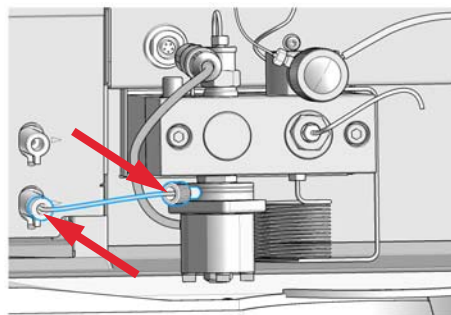

- 11** Reconnect the Active Inlet Valve cable to the connector in the Z-panel.

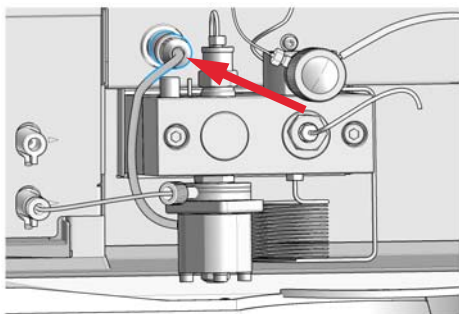

- 12** Close the doors.

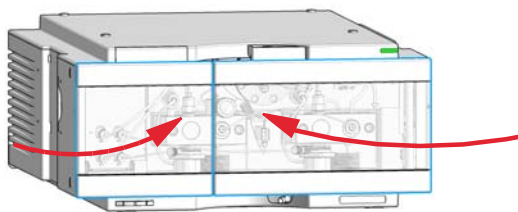
**NOTE**

After an exchange of the valve it may be required to pump several mL of the solvent used in the current application before the flow stabilizes at a pressure ripple as low as it used to be when the system was still working properly.

8 Maintenance

Exchange the Seal Wash Cartridge

Exchange the Seal Wash Cartridge

Parts required	p/n	Description
	5065-4445	Peristaltic pump with Pharmed tubing

- Preparations**
- Switch off pump at the main power switch.
 - Open the doors.

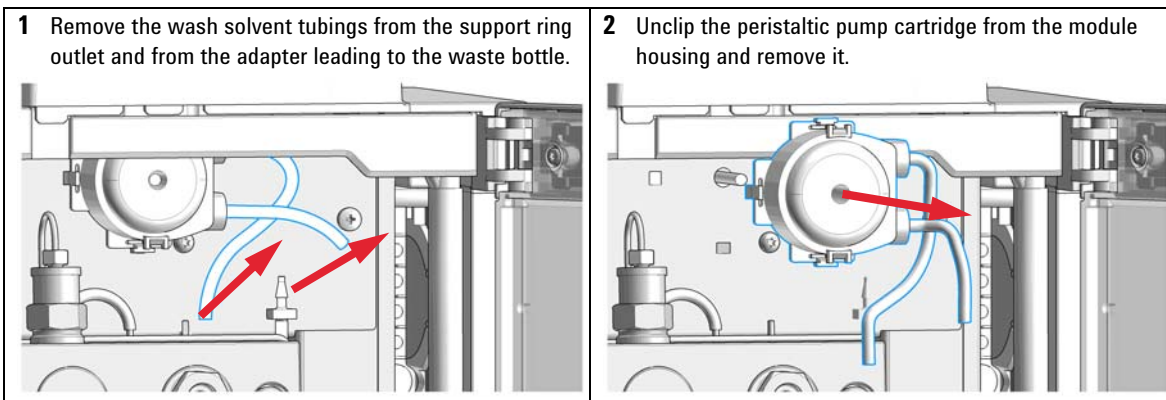

Exchange the Seal Wash Cartridge

- 3** Put the new peristaltic pump cartridge onto the rod of the pump motor and push the plastic clips into the module housing.

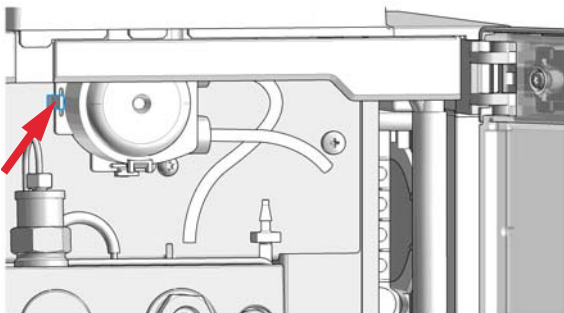
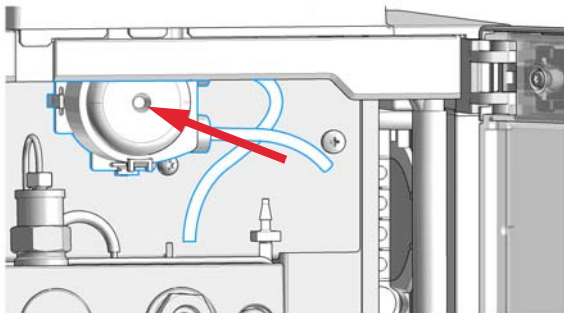

- 4** Connect the peristaltic pump tubes to the support rings outlet and to the adapter leading to the waste bottle.

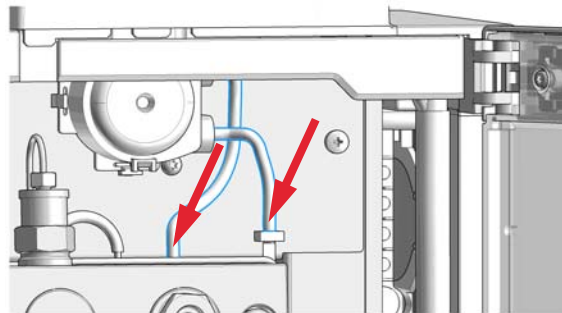

Replace Leak Handling System Parts

Parts required	p/n	Description
	5063-6527	Tubing assembly, i.d. 6 mm, o.d. 9 mm, 1.2 m (to waste) approximately 85 mm required

1 Open the doors.

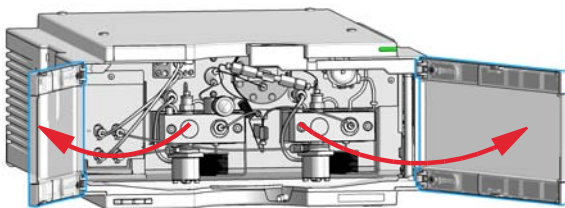

2 Press the Leak Adapter down (1.) and remove it together with the tubing (2.).

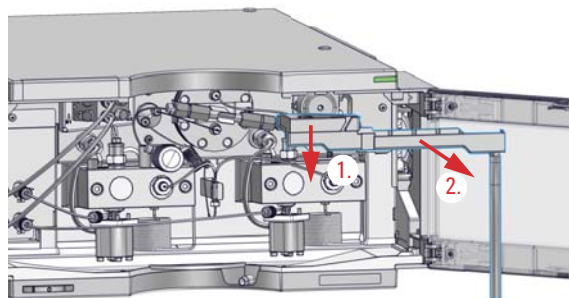

3 Install the Leak Adapter by pressing it into the Main Cover.

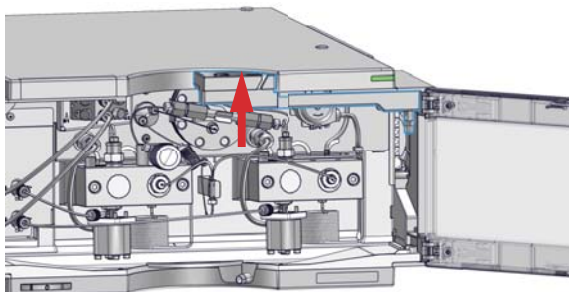

4 Insert the Tubing (approximately 85 mm required for replacement) between Leak Adapter outlet and Leak Panel.

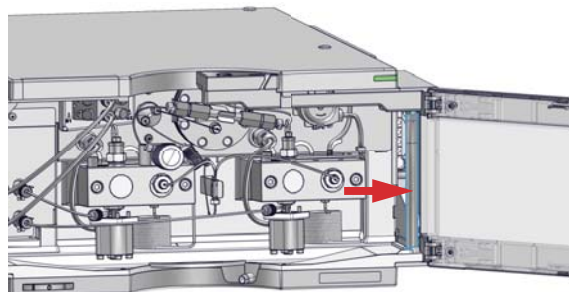

5 Close the doors.

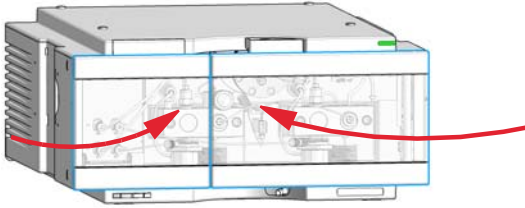

Exchange the Outlet Valve

When if leaking internally

Tools required	p/n	Description
	8710-1924	Open-end wrench 14 mm
	8710-0510	Open-end wrench 1/4 — 5/16 inch
	5067-5688	Torque wrench 1 – 25 Nm with 14 mm wrench

Parts required	#	p/n	Description
	1	G1312-60167	Outlet valve Channel A
	2	G1312-60067	Outlet valve Channel B

Preparations Switch off the pump at the main power switch

1 Using a ¼ inch wrench disconnect the absorber capillary from the outlet valve.

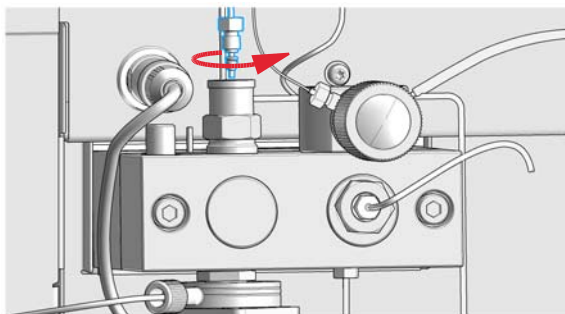

2 Unscrew the valve with the 14 mm wrench and remove it from the pump body.

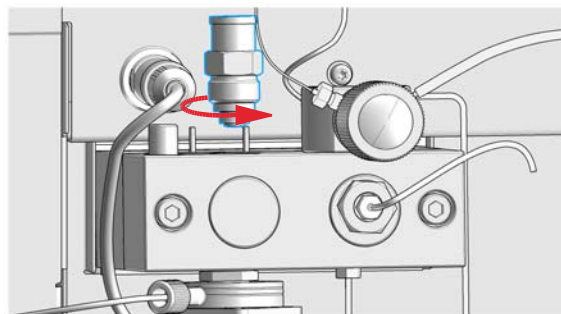

NOTE

Do not disassemble the outlet valve, as this can damage the valve.

- 3** Reinstall the outlet valve and tighten it using a torque wrench (approx.12 Nm).

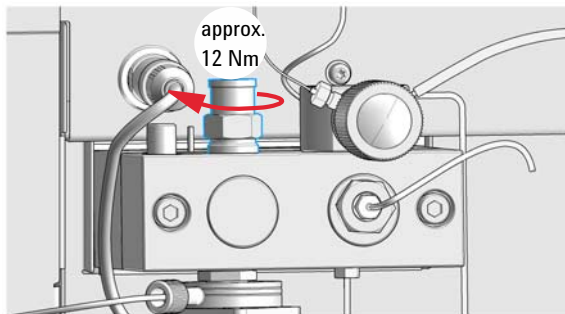

- 4** Reconnect the capillary.

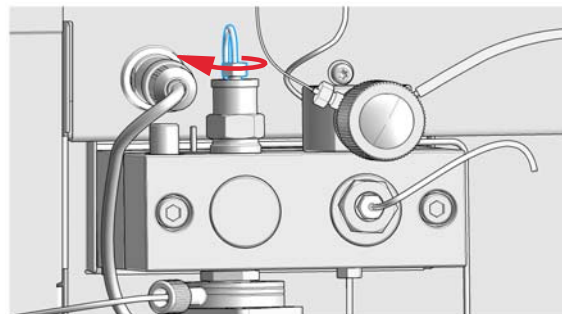

8 Maintenance

Installation of the Solvent Selection Valve Upgrade Kit

Installation of the Solvent Selection Valve Upgrade Kit

A solvent selection valve allows you to choose between four different solvents that can be used with a binary pump. The valve switches between two solvents A1 and A2 for channel A of the left pump head and two solvents B1 and B2 for channel B of the right pump head.

Tools required	p/n	Description
	8710-0899	Screwdriver Pozidrive Shaft
Parts required	p/n	Description
	G1381B	Solvent Selection Valve Upgrade Kit
Preparations	Remove the solvent tubes from the Degasser	

1 Break out the metal sheet piece to get access to the connection socket inside (behind the pump front metal panel).

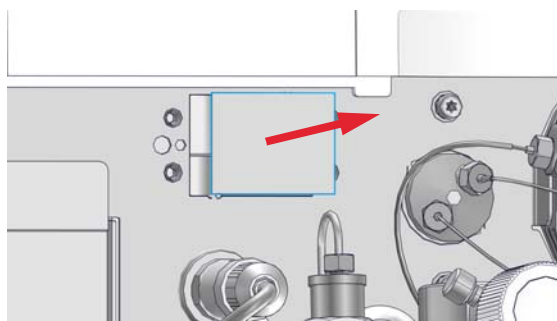

2 Guide the SSV cable through the slots in the distance sheet and route it through the slot in the pump front metal panel to the internal connection socket.

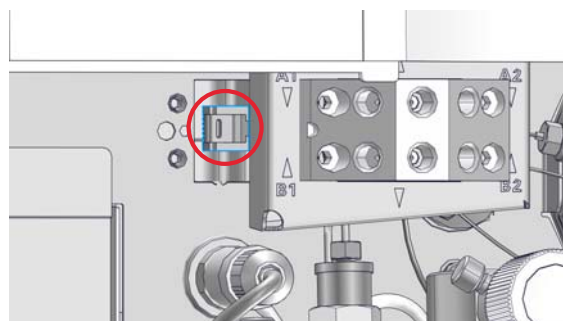

Installation of the Solvent Selection Valve Upgrade Kit

- 3** Carefully plug in the connector of the solvent selection valve into the internal connection socket on the left side of the slot behind the pump front metal panel.

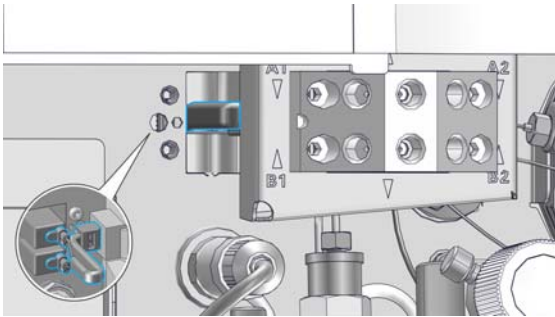

- 4** Install the solvent selection assembly by fixing the indicated screws with distance sheet under the SSV body.

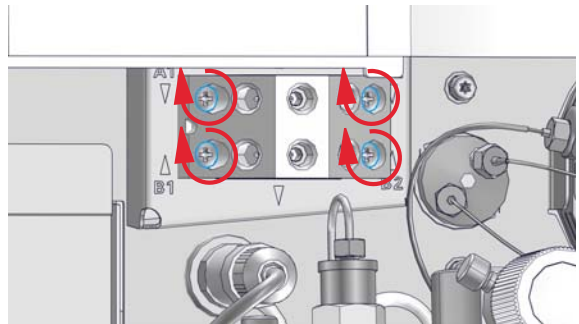

- 5** Connect the outlet of solvent A (upper row) to the top degasser inlet and the outlet of solvent B (lower row) to the bottom degasser inlet. Put the solvent bottles into the solvent cabinet. Connect the bottle heads of solvents A1 and A2 to the inlets in the upper row, see labels on valve assembly. Connect the bottle heads of solvents B1 and B2 to the inlets in the lower row, see labels on valve assembly.

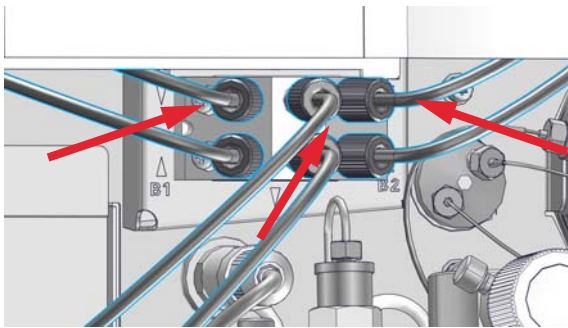
**NOTE**

Block unused channels of the SSV using a plug (Blank plug (5041-8365)) to avoid leaks or air entering the solvent channels.

NOTE

Before using of the system with a new installed valve it may be required to pump several mL of solvent to get the flow stabilized at a pressure ripple as low as it used to be when the system was still working properly.

8 Maintenance

Exchange the Solvent Selection Valve

Exchange the Solvent Selection Valve

When If leaking internally (crossflow between the ports), or if one of the channels is blocked

Tools required	p/n	Description
	8710-0899	Screwdriver Pozidrive Shaft

Parts required	p/n	Description
	5067-5895	Solvent selection valve

Preparations Switch off the pump at the main power switch

1 Lift solvent bottles out of the solvent cabinet and place them on the table. Disconnect the solvent tubes from the solvent selection valve and empty the tubes into the bottles. Place the bottles back into the solvent cabinet.

2 Disconnect all tubings from the solvent selection valve.

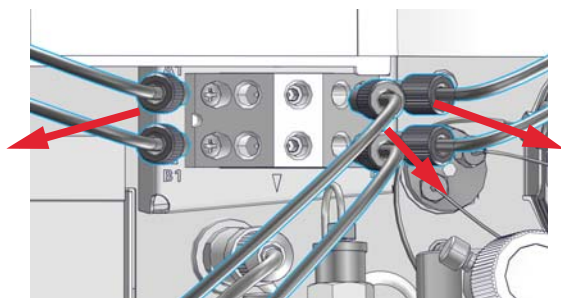

3 Using a screwdriver, loosen the holding screws of the valve holder.

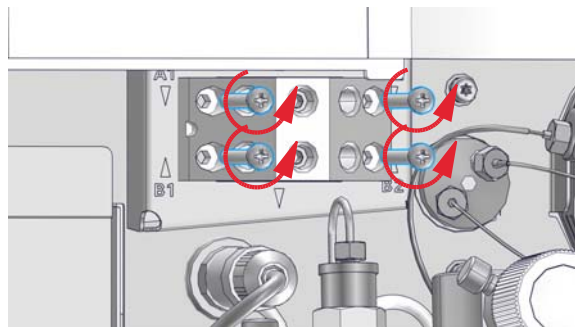

4 Carefully pull the valve holder out.

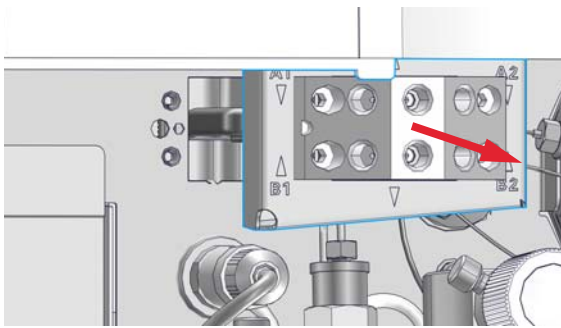

Exchange the Solvent Selection Valve

- 5** Disconnect the valve cable from the internal connection socket by pressing the fixing clip through the left side middle hole with the screwdriver.

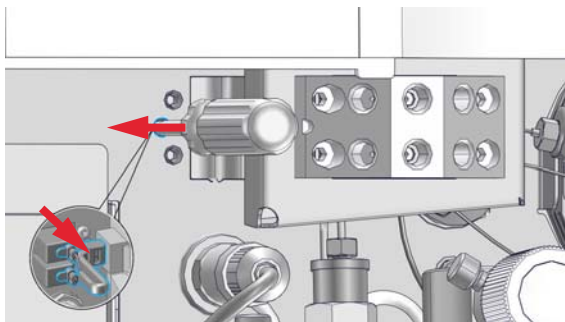

- 6** Completely remove the old valve.

- 7** Bend the cable at the connector of the new valve.

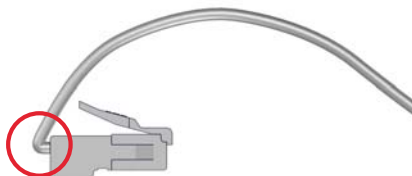

- 8** Guide the cable and connector into the hole and push the connector into the socket.

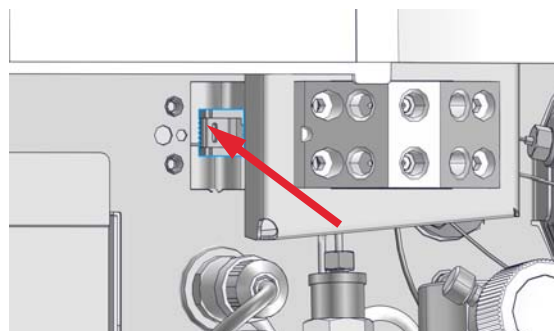

- 9** Exchange the defective solvent selection valve.

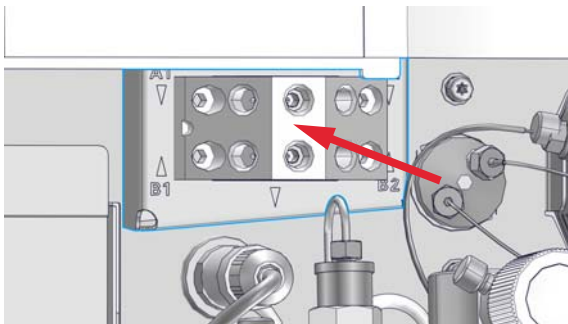

- 10** Tighten the screws of the valve holder.

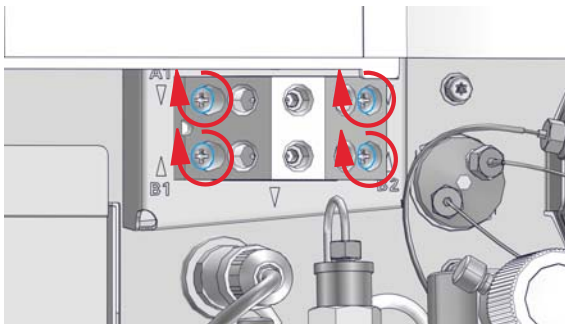

8 Maintenance

Exchange the Solvent Selection Valve

11 Reconnect all tubings to the solvent selection valve.

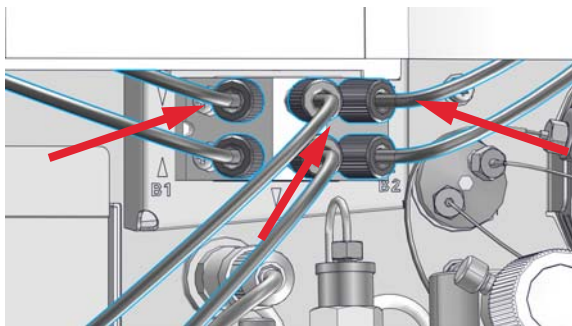

NOTE

After an exchange of the valve it may be required to pump several mL of solvent before the flow stabilizes at a pressure ripple as low as it used to be when the system was still working properly.

Replacing Module Firmware

When

The installation of newer firmware might be necessary

- if a newer version solves problems of older versions or
- to keep all systems on the same (validated) revision.

The installation of older firmware might be necessary

- to keep all systems on the same (validated) revision or
- if a new module with newer firmware is added to a system or
- if third party control software requires a special version.

Tools required

Description

Agilent Lab Advisor software

Parts required

#	Description
1	Firmware, tools and documentation from Agilent web site

Preparations

Read update documentation provided with the Firmware Update Tool.

To upgrade/downgrade the module’s firmware carry out the following steps:

- 1** Download the required module firmware, the latest FW Update Tool and the documentation from the Agilent web.
<http://www.agilent.com/en-us/firmwareDownload?whid=69761>
- 2** For loading the firmware into the module follow the instructions in the documentation.

Module Specific Information

There is no specific information for this module.

8 Maintenance

Replacing Module Firmware

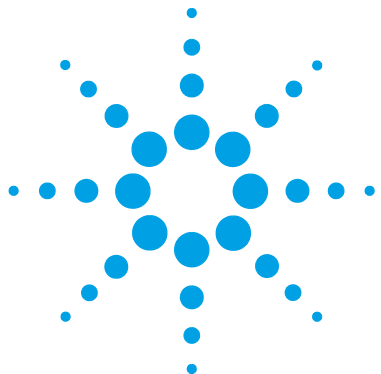

9 Parts and Materials for Maintenance

Hydraulic Path with Solvent Selection Valve	154
Hydraulic Path without Solvent Selection Valve	156
Pump Head Assembly Without Seal Wash	158
Pump Head Assembly with Seal Wash Option	160
Outlet Valve	162
Purge Valve Assembly	163
Active Inlet Valve Assembly	164
HPLC System Tool Kit	165
Active Seal Wash Option	166
Solvent Cabinet	167
Bottle Head Assembly	168
Cover Parts	169
Accessory Kit	170

This chapter lists all parts and tools that are required for maintenance and simple repairs.



Hydraulic Path with Solvent Selection Valve

Item	#	p/n	Description
1	1	5067-5895	Solvent selection valve
	1	5041-8365	Blank plug for unused SSV channels
2	2	G7111-60100	Solvent Tubes including labels Solvent selection valve to degasser
3	1	G7112-60070	Degasser Unit 2 Channels
4	1	G1311-67304	Connecting tube Degasser to Channel A
5	1	G7112-67300	Connecting Tube Degasser to Channel B
6	1	G1312-60025	Active inlet valve body, without cartridge
7	1	G1312-60045	Pump head assembly with seal wash
8	1	G1312-60067	Outlet valve
9	1	G1312-87300	Absorber capillary
10	1	G1312-67302	Capillary, channel A and B pump head outlet to mixing chamber (included)
11	1	G1312-87301	Restriction capillary (mixing capillary to pressure sensor)
13	1	G1312-87305	Capillary SSL, 0.17 x 150 mm (pressure sensor to damper)
15	1	G1312-87330	Mixer
16	1	G1312-87306	Capillary SSL, 0.17 x 105 mm (connections to solvent mixer)
	1	G1312-04100	Bracket for solvent mixer
17	1	G7111-60061	Purge valve
18	1	5500-1246	Capillary ST 0.17 mm x 500 mm SI/SI
	1	5500-1217	Capillary ST 0.17 mm x 900 mm SI/SX ps-ps
19	1	5064-5444	Peristaltic pump cartridge, silicone tubing
	1	5065-9978	Tubing, 1 mm i.d., 3 mm o.d., silicone, 5 m for seal wash option
20	1	5062-2461	Waste tube, 5 m (reorder pack)

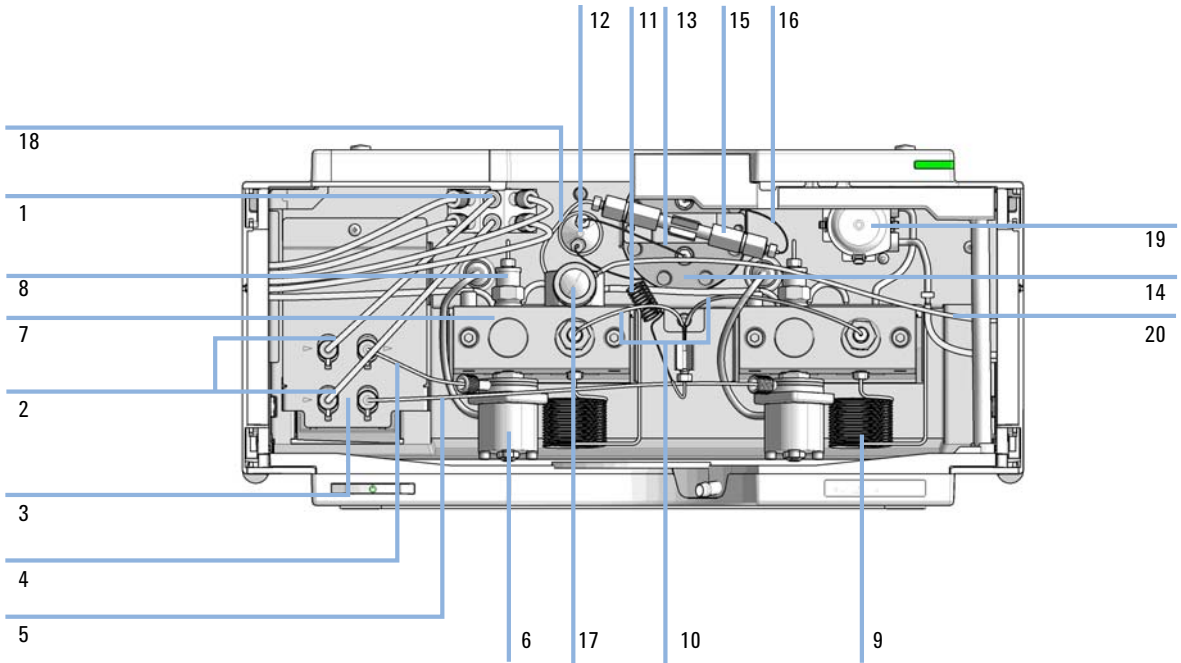

Figure 11 Hydraulic Path with Solvent Selection Valve

Hydraulic Path without Solvent Selection Valve

Item	p/n	Description
1	G7112-60070	Degasser Unit 2 Channels
2	G1311-67304	Connecting tube Degasser to Channel A
3	G7112-67300	Connecting Tube Degasser to Channel B
4	G1312-60025	Active inlet valve body, without cartridge
5	G1312-60056	Pump Head 1200 SL without Seal Wash
6	G1312-60067	Outlet valve
7	G1312-87300	Absorber capillary
8	G1312-67302	Capillary, channel A and B pump head outlet to mixing chamber (included)
9	G1312-87301	Restriction capillary (mixing capillary to pressure sensor)
11	G1312-87305	Capillary SSL, 0.17 x 150 mm (pressure sensor to damper)
13	G1312-87330	Mixer
14	G1312-87306	Capillary SSL, 0.17 x 105 mm (connections to solvent mixer)
	G1312-04100	Bracket for solvent mixer
15	G7111-60061	Purge valve
16	5500-1246	Capillary ST 0.17 mm x 500 mm SI/SI
	5500-1217	Capillary ST 0.17 mm x 900 mm SI/SX ps-ps
17	5065-4445	Peristaltic pump with Pharmed tubing
18	5062-2461	Waste tube, 5 m (reorder pack)
	5065-9978	Tubing, 1 mm i.d., 3 mm o.d., silicone, 5 m for seal wash option

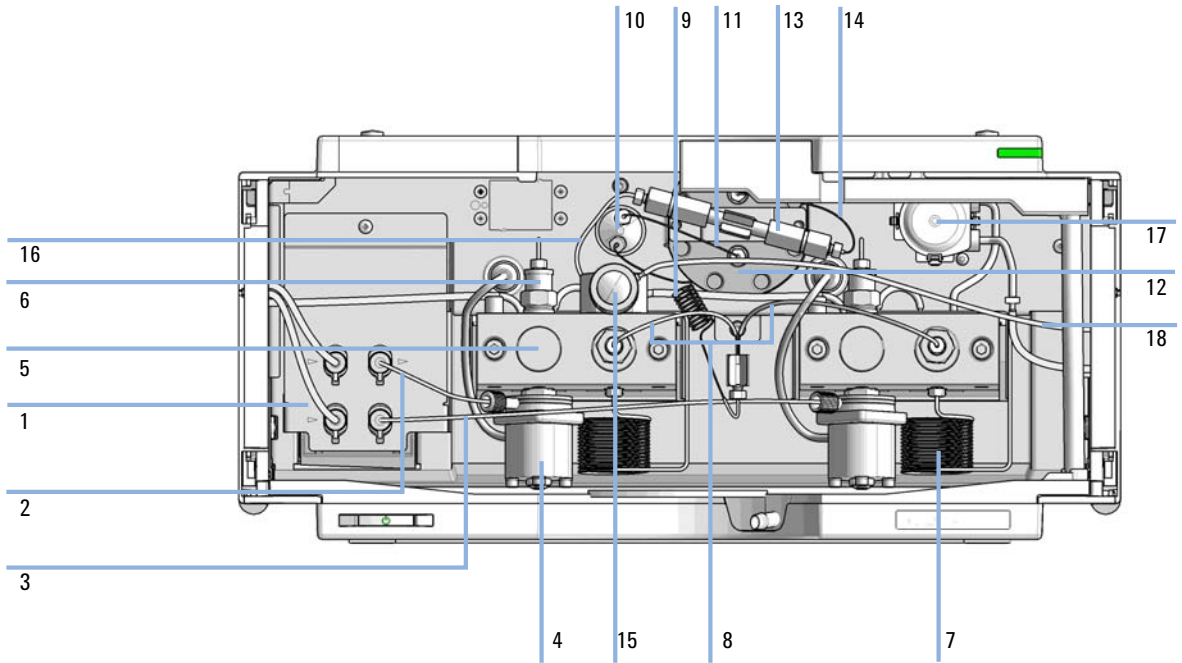

Figure 12 Hydraulic Path without Solvent Selection Valve, with Active Seal Wash

Pump Head Assembly Without Seal Wash

Item	p/n	Description
	G1312-60056	Pump Head 1200 SL without Seal Wash
1	5063-6586	Sapphire piston
2	G1311-60002	Piston housing
3	5067-1560	Support Ring SL, no seal wash
4	G1312-87300	Absorber capillary
5	5063-6589	Piston seal PTFE, carbon filled, black (pack of 2), default
6	G1311-25200	Pump chamber housing
7	0515-0175	Mounting screw for manual purge valve holder, M4, 20 mm long
8	G1312-23200	Holder for manual purge valve
9	G7111-60061	Purge valve
10	G1312-60067	Outlet valve
11	5042-1303	Lock screw
12 a	G1312-60025	Active inlet valve body, without cartridge
12 b	G1312-60020	Cartridge for active inlet valve 600 bar
13	G1312-23201	Adapter
14	0515-2118	Pump head screw (M5, 60 mm)

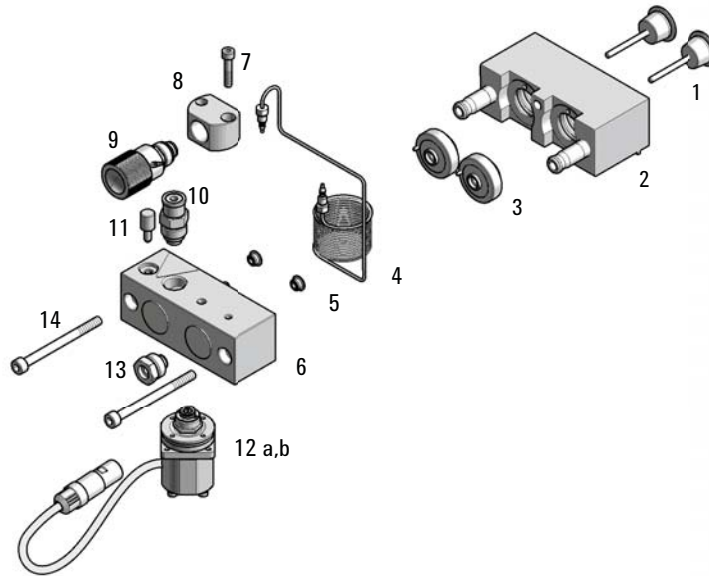

Figure 13 Pump Head Assembly Without Seal Wash

Pump Head Assembly with Seal Wash Option

Item	p/n	Description
	G1312-60045	Pump head assembly with seal wash
1	5065-9953	Seal wash pump assembly
	5067-5744	Cabinet Kit 180 Infinity II (includes sides, bottom, top, leak adapter top and Status Indicator Insert)
	5065-9978	Tubing, 1 mm i.d., 3 mm o.d., silicone, 5 m for seal wash option
2	5063-6586	Sapphire piston
3	G1311-60002	Piston housing
4	01018-60027	Support ring seal wash
5	0905-1175	Wash seal (PTFE)
OR	0905-1718	Wash Seal PE
6	5062-2484	Gasket, seal wash (pack of 6)
7	5042-8952	Seal holder
8	G1312-87300	Absorber capillary
9	5063-6589	Piston seal PTFE, carbon filled, black (pack of 2), default
OR	0905-1420	PE seals (pack of 2)
10	0515-0175	Mounting screw for manual purge valve holder, M4, 20 mm long
11	G1312-23200	Holder for manual purge valve
12	G7111-60061	Purge valve
13	G1312-60067	Outlet valve
14	5042-1303	Lock screw
15	G1311-25200	Pump chamber housing
16a	G1312-60025	Active inlet valve body, without cartridge
16b	G1312-60020	Cartridge for active inlet valve 600 bar
17	G1312-23201	Adapter
18	0515-2118	Pump head screw (M5, 60 mm)

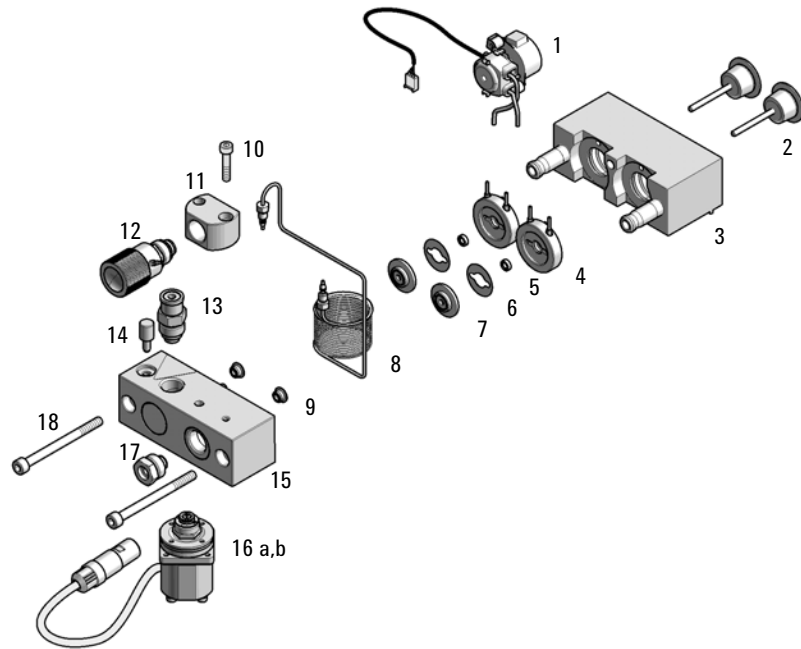

Figure 14 Pump Head Assembly with Seal Wash Option

Outlet Valve

p/n	Description
G1312-60067	Outlet valve

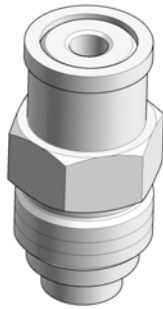

Figure 15 Outlet valve

Purge Valve Assembly

Item	p/n	Description
1	G7111-60061	Purge valve
2	01018-22707	PTFE frits (pack of 5)
3	5067-4728	Seal cap
	5067-6595	1260 PV O-ring FKM 5/pack

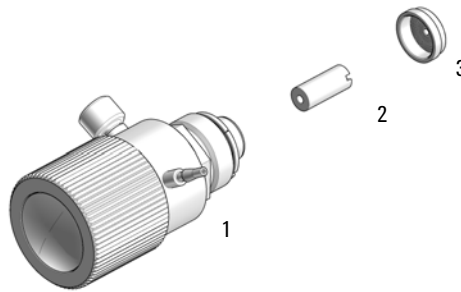

Figure 16 Purge Valve Assembly

Active Inlet Valve Assembly

Item	p/n	Description
1	G1312-60025	Active inlet valve body, without cartridge
2	G1312-60020	Cartridge for active inlet valve 600 bar

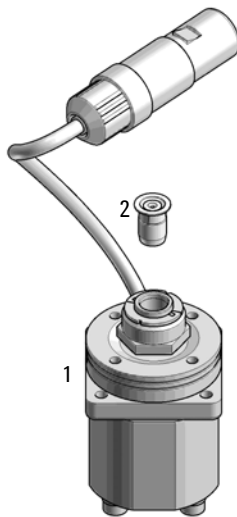

Figure 17 Active Inlet Valve Assembly

HPLC System Tool Kit



Active Seal Wash Option

The Active Seal Wash Option kit (G1399B) contains the following parts:

#	p/n	Description
1	5062-2484	Gasket, seal wash (pack of 6)
1	01018-23702	Insert tool
4	01018-60027	Support ring seal wash
2	0515-1508	Screws for Seal Wash Pump Motor
1	5065-9978	Tubing, 1 mm i.d., 3 mm o.d., silicone, 5 m
4	0905-1175	Wash seal (PTFE)
1	5063-6589	Piston seal PTFE, carbon filled, black (pack of 2), default
1	1460-2763	Compression Spring SST
2	1520-0260	Shock mount
1	1540-0455	Edge protector
1	5041-2120	Folding box
1	5065-4445	Peristaltic pump with Pharmed tubing
1	5042-6422	Tubing connector, 1 mm o.d.
1	5065-9943	Stepper Motor for the Peristaltic Pump
1	G3010-01203	RFI Strip 10×30

Solvent Cabinet

p/n	Description
5067-5760	Solvent Cabinet Kit

 $V_{\max} = 8.1 \text{ L}$

$$V_1 + V_2 + V_3 + \dots < V_{\max}$$

5067-5760

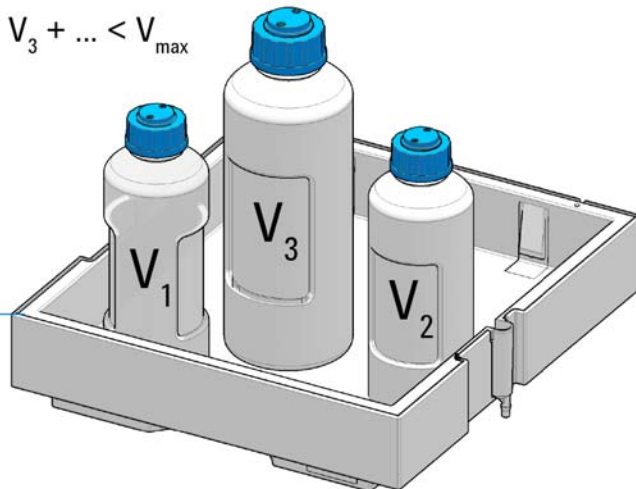

For details refer to: Usage Guideline for the Solvent Cabinet (01200-90150)

Bottle Head Assembly

The Bottle Head Assembly (G7120-60007) contains:

p/n	Description
5063-6598	Ferrules with lock ring (10/Pk)
5063-6599	Tube screw (10/Pk)
	Wire marker
5062-2483	Tube PTFE 1.5 mm x 5 m, 3 mm od
5062-8517	Inlet filter adapter (4/Pk)
5041-2168	Solvent inlet filter, 20 µm pore size

Cover Parts

Item	p/n	Description
1	5067-5746	Door Assembly Infinity 180 Right
2	5067-5745	Door Assembly Infinity 180 Left
3	5043-1354	Name Plate 1290 Infinity 2
4	G7104-68713	Cabinet Kit 180 Infinity II (includes sides, bottom, top, leak adapter top and Status Indicator Insert)

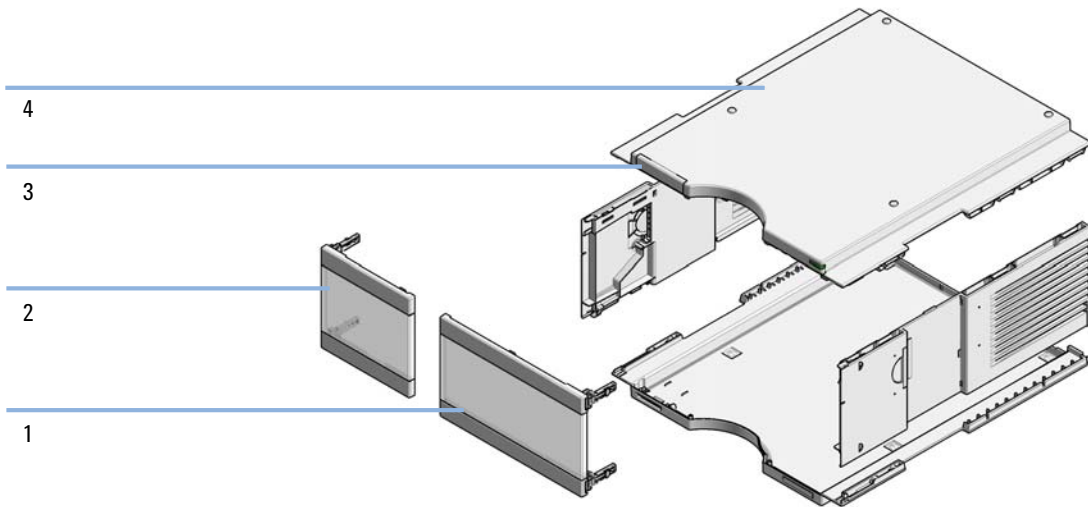
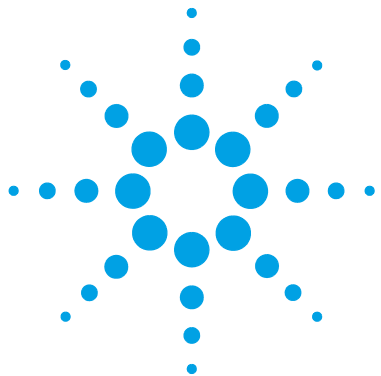

Figure 18 Cover Parts

Accessory Kit

The Accessory Kit (G7111-68755) contains the following items:

Item	#	p/n	Description
1	2	5043-1013	Tubing Clip
2	1	5181-1519	CAN cable, Agilent module to module, 1 m
3	1	5500-1246	Capillary ST 0.17 mm x 500 mm SI/SI
4	1	5500-1217	Capillary ST 0.17 mm x 900 mm SI/SX ps-ps
5	3	5063-6527	Tubing assembly, i.d. 6 mm, o.d. 9 mm, 1.2 m (to waste)
6	1	G1311-90107	Algae note
7	3	5500-1169	Y Tube Connector ID 6.4
8	3	5500-1155	Tube Connector, 90 degree, ID 6.4
9	1	5043-1372	Tubing Connector Leak 3-1
10	2	5043-1373	Tubing Connector Leak Cap
11	2	0890-1195	PTFE tubing, 0.052 in i.d.



10 Identifying Cables

Cable Overview	172
Analog Cables	174
Remote Cables	176
CAN/LAN Cables	180
RS-232 Cable Kit	181
Agilent 1200 Module to Printer	182

This chapter provides information on cables used with the Agilent InfinityLab LC Series modules.



Cable Overview

NOTE

Never use cables other than the ones supplied by Agilent Technologies to ensure proper functionality and compliance with safety or EMC regulations.

Analog cables

p/n	Description
35900-60750	Agilent 35900A A/D converter
01046-60105	Analog cable (BNC to general purpose, spade lugs)

Remote cables

p/n	Description
5188-8029	ERI to general purpose
5188-8044	Remote Cable ERI – ERI
5188-8045	Remote Cable APG – ERI
5188-8059	ERI-Extension-Cable 1.2 m
5061-3378	Remote Cable to 35900 A/D converter
01046-60201	Agilent module to general purpose
5188-8057	Fraction Collection ERI remote Y-cable

CAN cables

p/n	Description
5181-1516	CAN cable, Agilent module to module, 0.5 m
5181-1519	CAN cable, Agilent module to module, 1 m

LAN cables

p/n	Description
5023-0203	Cross-over network cable, shielded, 3 m (for point to point connection)
5023-0202	Twisted pair network cable, shielded, 7 m (for point to point connection)

**RS-232 cables
(not for FUSION
board)**

p/n	Description
RS232-61601	RS-232 cable, 2.5 m Instrument to PC, 9-to-9 pin (female). This cable has special pin-out, and is not compatible with connecting printers and plotters. It's also called "Null Modem Cable" with full handshaking where the wiring is made between pins 1-1, 2-3, 3-2, 4-6, 5-5, 6-4, 7-8, 8-7, 9-9.
5181-1561	RS-232 cable, 8 m

USB cables

p/n	Description
5188-8050	USB A M-USB Mini B 3 m (PC-Module)
5188-8049	USB A F-USB Mini B M OTG (Module to Flash Drive)

Analog Cables



One end of these cables provides a BNC connector to be connected to Agilent modules. The other end depends on the instrument to which connection is being made.

Agilent Module to 35900 A/D converters

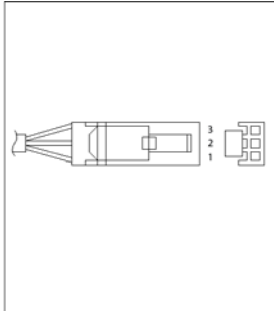
p/n 35900-60750	35900	Pin Agilent module	Signal Name
	1		Not connected
	2	Shield	Analog -
	3	Center	Analog +

Agilent Module to BNC Connector

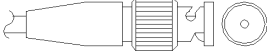
p/n 8120-1840	Pin BNC	Pin Agilent module	Signal Name
	Shield	Shield	Analog -
	Center	Center	Analog +

Agilent Module to General Purpose

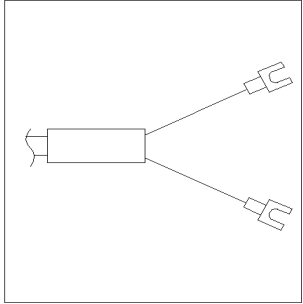
p/n 01046-60105	Pin	Pin Agilent module	Signal Name
	1		Not connected
	2	Black	Analog -
	3	Red	Analog +

Remote Cables

ERI (Enhanced Remote Interface)

- 5188-8029 ERI to general purpose (D-Sub 15 pin male - open end)
- 5188-8044 ERI to ERI (D_Sub 15 pin male - male)
- 5188-8059 ERI-Extension-Cable 1.2 m (D-Sub15 pin male / female)

p/n 5188-8029	pin	Color code	Enhanced Remote	Classic Remote	Active (TTL)
<p>D-Sub female 15way user's view to connector</p>	1	white	I01	START REQUEST	Low
	2	brown	I02	STOP	Low
	3	green	I03	READY	High
	4	yellow	I04	POWER ON	High
	5	grey	I05	NOT USED	
	6	pink	I06	SHUT DOWN	Low
	7	blue	I07	START	Low
	8	red	I08	PREPARE	Low
	9	black	1wire DATA		
	10	violet	DGND		
	11	grey-pink	+5V ERI out		
	12	red-blue	PGND		
	13	white-green	PGND		
	14	brown-green	+24V ERI out		
	15	white-yellow	+24V ERI out		
	NC	yellow-brown			

- 5188-8045 ERI to APG (Connector D_Subminiature 15 pin (ERI), Connector D_Subminiature 9 pin (APG))

p/n 5188-8045	Pin (ERI)	Signal	Pin (APG)	Active (TTL)
	10	GND	1	
	1	Start Request	9	Low
	2	Stop	8	Low
	3	Ready	7	High
	5	Power on	6	High
	4	Future	5	
	6	Shut Down	4	Low
	7	Start	3	Low
	8	Prepare	2	Low
	Ground	Cable Shielding	NC	

10 Identifying Cables

Remote Cables

- 5188-8057 ERI to APG and RJ45 (Connector D_Subminiature 15 pin (ERI), Connector D_Subminiature 9 pin (APG), Connector plug Cat5e (RJ45))

Table 13 5188-8057 ERI to APG and RJ45

p/n 5188-8057	Pin (ERI)	Signal	Pin (APG)	Active (TTL)	Pin (RJ45)
	10	GND	1		5
	1	Start Request	9	High	
	2	Stop	8	High	
	3	Ready	7	High	
	4	Fraction Trigger	5	High	4
	5	Power on	6	High	
	6	Shut Down	4	High	
	7	Start	3	High	
	8	Prepare	2	High	
	Ground	Cable Shielding	NC		



One end of these cables provides a Agilent Technologies APG (Analytical Products Group) remote connector to be connected to Agilent modules. The other end depends on the instrument to be connected to.

Agilent Module to Agilent 35900 A/D Converters

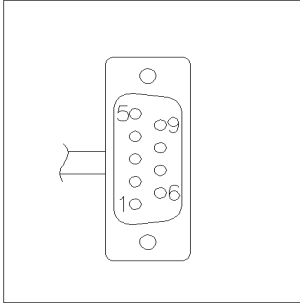
p/n 5061-3378	Pin 35900 A/D	Pin Agilent module	Signal Name	Active (TTL)
	1 - White	1 - White	Digital ground	
	2 - Brown	2 - Brown	Prepare run	Low
	3 - Gray	3 - Gray	Start	Low
	4 - Blue	4 - Blue	Shut down	Low
	5 - Pink	5 - Pink	Not connected	
	6 - Yellow	6 - Yellow	Power on	High
	7 - Red	7 - Red	Ready	High
	8 - Green	8 - Green	Stop	Low
	9 - Black	9 - Black	Start request	Low

Agilent Module to General Purpose

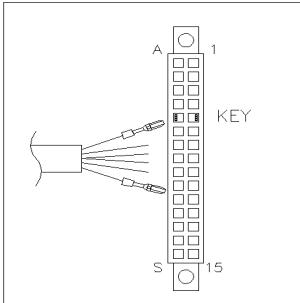
p/n 01046-60201	Wire Color	Pin Agilent module	Signal Name	Active (TTL)
	White	1	Digital ground	
	Brown	2	Prepare run	Low
	Gray	3	Start	Low
	Blue	4	Shut down	Low
	Pink	5	Not connected	
	Yellow	6	Power on	High
	Red	7	Ready	High
	Green	8	Stop	Low
	Black	9	Start request	Low

CAN/LAN Cables

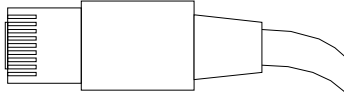

Both ends of this cable provide a modular plug to be connected to Agilent modules CAN or LAN connectors.

CAN Cables

p/n	Description
5181-1516	CAN cable, Agilent module to module, 0.5 m
5181-1519	CAN cable, Agilent module to module, 1 m

LAN Cables

p/n	Description
5023-0203	Cross-over network cable, shielded, 3 m (for point to point connection)
5023-0202	Twisted pair network cable, shielded, 7 m (for point to point connection)

RS-232 Cable Kit

p/n	Description
RS232-61601	RS-232 cable, 2.5 m Instrument to PC, 9-to-9 pin (female). This cable has special pin-out, and is not compatible with connecting printers and plotters. It's also called "Null Modem Cable" with full handshaking where the wiring is made between pins 1-1, 2-3, 3-2, 4-6, 5-5, 6-4, 7-8, 8-7, 9-9.
5181-1561	RS-232 cable, 8 m

10 Identifying Cables

Agilent 1200 Module to Printer

Agilent 1200 Module to Printer

To connect a USB Flash Drive use a USB OTG cable with Mini-B plug and A socket.

p/n	Description
5188-8050	USB A M-USB Mini B 3 m (PC-Module)
5188-8049	USB A F-USB Mini B M OTG (Module to Flash Drive)



11 Hardware Information

Firmware Description	184
Electrical Connections	187
Serial Number Information (ALL)	188
Rear view of the module	188
Interfaces	189
Overview Interfaces	191
ERI (Enhanced Remote Interface)	194
USB (Universal Serial Bus)	196
Setting the 6-bit Configuration Switch	197
Special Settings	199
Early Maintenance Feedback	201
Instrument Layout	202

This chapter provides detailed technical information about your binary pump.



Firmware Description

The firmware of the instrument consists of two independent sections:

- a non-instrument specific section, called *resident system*
- an instrument specific section, called *main system*

Resident System

This resident section of the firmware is identical for all Agilent 1100/1200/1220/1260/1290 series modules. Its properties are:

- the complete communication capabilities (CAN, LAN, USB and RS- 232)
- memory management
- ability to update the firmware of the 'main system'

Main System

Its properties are:

- the complete communication capabilities (CAN, LAN, USB and RS- 232)
- memory management
- ability to update the firmware of the 'resident system'

In addition the main system comprises the instrument functions that are divided into common functions like

- run synchronization through APG/ERI remote,
- error handling,
- diagnostic functions,
- or module specific functions like
 - internal events such as lamp control, filter movements,
 - raw data collection and conversion to absorbance.

Firmware Updates

Firmware updates can be done with the Agilent Lab Advisor software with files on the hard disk (latest version should be used).

Required tools, firmware and documentation are available from the Agilent web: <http://www.agilent.com/en-us/firmwareDownload?whid=69761>

The file naming conventions are:

PPPP_RVVV_XXX.dlb, where

- PPPP is the product number, for example, 1315B for the G1315B DAD,
- R the firmware revision, for example, A for G1315B or B for the G1315C DAD,
- VVV is the revision number, for example 650 is revision 6.50,
- XXX is the build number of the firmware.

For instructions on firmware updates refer to section *Replacing Firmware* in chapter "Maintenance" or use the documentation provided with the *Firmware Update Tools*.

NOTE

Update of main system can be done in the resident system only. Update of the resident system can be done in the main system only.

Main and resident firmware must be from the same set.

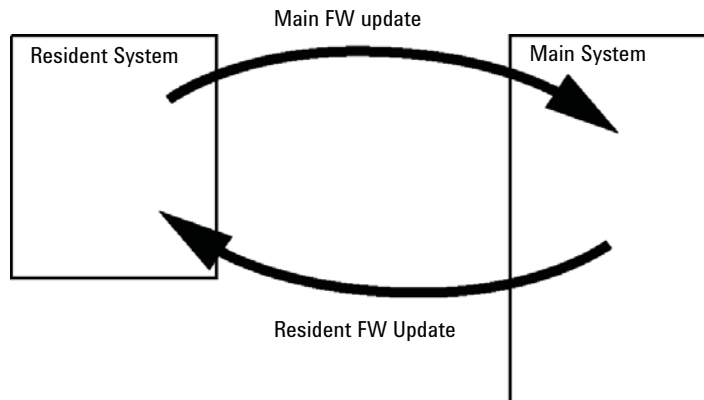

Figure 19 Firmware Update Mechanism

11 Hardware Information

Firmware Description

NOTE

Some modules are limited in downgrading due to their main board version or their initial firmware revision. For example, a G1315C DAD SL cannot be downgraded below firmware revision B.01.02 or to a A.xx.xx.

Some modules can be re-branded (e.g. G1314C to G1314B) to allow operation in specific control software environments. In this case, the feature set of the target type is used and the feature set of the original one is lost. After re-branding (e.g. from G1314B to G1314C), the original feature set is available again.

All this specific information is described in the documentation provided with the firmware update tools.

The firmware update tools, firmware and documentation are available from the Agilent web.

- <http://www.agilent.com/en-us/firmwareDownload?whid=69761>

Electrical Connections

- The CAN bus is a serial bus with high-speed data transfer. The two connectors for the CAN bus are used for internal module data transfer and synchronization.
- The ERI/REMOTE connector may be used in combination with other analytical instruments from Agilent Technologies if you want to use features such as start, stop, common shutdown, prepare, and so on.
- With the appropriate software, the LAN connector may be used to control the module from a computer through a LAN connection. This connector is activated and can be configured with the configuration switch.
- With the appropriate software, the USB connector may be used to control the module from a computer through a USB connection.
- The power input socket accepts a line voltage of 100 – 240 VAC \pm 10 % with a line frequency of 50 or 60 Hz. Maximum power consumption varies by module. There is no voltage selector on your module because the power supply has wide-ranging capability. There are no externally accessible fuses because automatic electronic fuses are implemented in the power supply.

NOTE

Never use cables other than the ones supplied by Agilent Technologies to ensure proper functionality and compliance with safety or EMC regulations.

Serial Number Information (ALL)

The serial number information on the instrument labels provide the following information:

CCXZZ00000	Format
CC	Country of manufacturing <ul style="list-style-type: none">• DE = Germany• JP = Japan• CN = China
X	Alphabetic character A-Z (used by manufacturing)
ZZ	Alpha-numeric code 0-9, A-Z, where each combination unambiguously denotes a module (there can be more than one code for the same module)
00000	Serial number

Rear view of the module

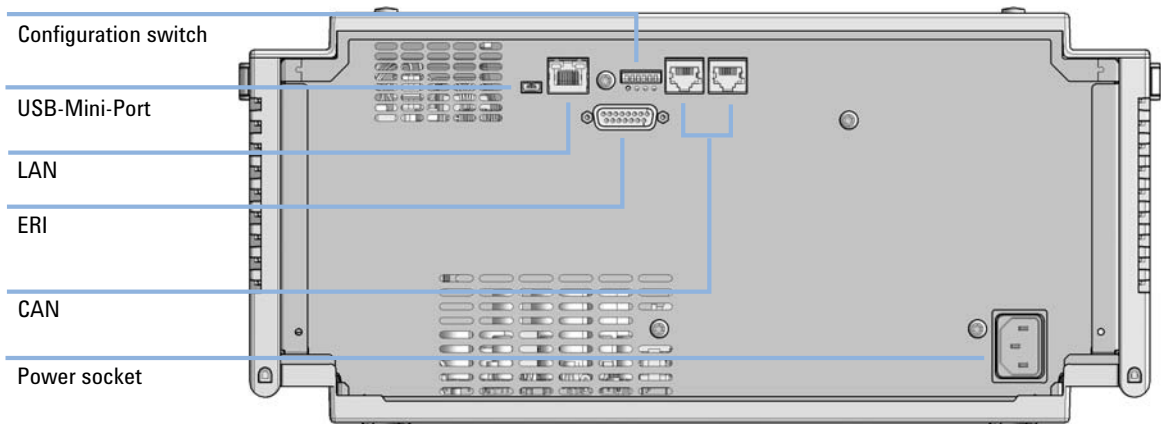

Figure 20 Rear view of the pump – electrical connections and label

Interfaces

The Agilent InfinityLab LC Series modules provide the following interfaces:

Table 14 Agilent InfinityLab LC Series Interfaces

Module	CAN	USB	LAN (on-board)	RS-232	Analog	APG (A) / ERI (E)	Special
Pumps							
G7104A/C	2	No	Yes	Yes	1	A	
G7110B	2	Yes	Yes	No	No	E	
G7111A/B, G5654A	2	Yes	Yes	No	No	E	
G7112B	2	Yes	Yes	No	No	E	
G7120A	2	No	Yes	Yes	1	A	
G7161A/B	2	Yes	Yes	No	No	E	
Samplers							
G7129A/B/C	2	Yes	Yes	No	No	E	
G7167B/C, G5667A	2	Yes	Yes	No	No	E	
G7157A	2	Yes	Yes	No	No	E	
Detectors							
G7114A/B	2	Yes	Yes	No	1	E	
G7115A	2	Yes	Yes	No	1	E	
G7117A/B/C	2	Yes	Yes	No	1	E	
G7121A/B	2	Yes	Yes	No	1	E	
G7162A/B	2	Yes	Yes	No	1	E	
G7165A	2	Yes	Yes	No	1	E	

11 Hardware Information

Interfaces

Table 14 Agilent InfinityLab LC Series Interfaces

Module	CAN	USB	LAN (on-board)	RS-232	Analog	APG (A) / ERI (E)	Special
Fraction Collectors							
G7159B	2	Yes	Yes	No	No	E	
G7166A	2	No	No	No	No	No	Requires a host module with on-board LAN with minimum FW B.06.40 or C.06.40, or with additional G1369C LAN Card
G1364E/F, G5664B	2	Yes	Yes	No	No	E	THERMOSTAT for G1330B
Others							
G7116A/B	2	No	No	No	No	No	Requires a HOST module via CAN
G7122A	No	No	No	Yes	No	A	
G7170B	2	No	No	No	No	No	Requires a host module with on-board LAN with minimum FW B.06.40 or C.06.40, or with additional G1369C LAN Card

NOTE

The detector (DAD/MWD/FLD/VWD/RID) is the preferred access point for control via LAN. The inter-module communication is done via CAN.

- CAN connectors as interface to other modules
- LAN connector as interface to the control software
- RS-232C as interface to a computer
- USB (Universal Series Bus) as interface to a computer
- REMOTE connector as interface to other Agilent products
- Analog output connector(s) for signal output

Overview Interfaces

CAN

The CAN is inter-module communication interface. It is a 2-wire serial bus system supporting high speed data communication and real-time requirement.

LAN

The modules have either an interface slot for a LAN card (e.g. Agilent G1369B/C LAN Interface) or they have an on-board LAN interface (e.g. detectors G1315C/D DAD and G1365C/D MWD). This interface allows the control of the module/system via a PC with the appropriate control software. Some modules have neither on-board LAN nor an interface slot for a LAN card (e.g. G1170A Valve Drive or G4227A Flexible Cube). These are hosted modules and require a Host module with firmware B.06.40 or later or with additional G1369C LAN Card.

NOTE

If an Agilent detector (DAD/MWD/FLD/VWD/RID) is in the system, the LAN should be connected to the DAD/MWD/FLD/VWD/RID (due to higher data load). If no Agilent detector is part of the system, the LAN interface should be installed in the pump or autosampler.

USB

The USB interface replaces the RS-232 Serial interface in new FUSION generation modules. For details on USB refer to “[USB \(Universal Serial Bus\)](#)” on page 196.

Analog Signal Output

The analog signal output can be distributed to a recording device. For details refer to the description of the module’s main board.

Remote (ERI)

The ERI (Enhanced Remote Interface) connector may be used in combination with other analytical instruments from Agilent Technologies if you want to use features as common shut down, prepare, and so on.

It allows easy connection between single instruments or systems to ensure coordinated analysis with simple coupling requirements.

The subminiature D connector is used. The module provides one remote connector which is inputs/outputs (wired- or technique).

To provide maximum safety within a distributed analysis system, one line is dedicated to **SHUT DOWN** the system's critical parts in case any module detects a serious problem. To detect whether all participating modules are switched on or properly powered, one line is defined to summarize the **POWER ON** state of all connected modules. Control of analysis is maintained by signal readiness **READY** for next analysis, followed by **START** of run and optional **STOP** of run triggered on the respective lines. In addition **PREPARE** and **START REQUEST** may be issued. The signal levels are defined as:

- standard TTL levels (0 V is logic true, + 5.0 V is false),
- fan-out is 10,
- input load is 2.2 kOhm against + 5.0 V, and
- output are open collector type, inputs/outputs (wired- or technique).

NOTE

All common TTL circuits operate with a 5 V power supply. A TTL signal is defined as "low" or L when between 0 V and 0.8 V and "high" or H when between 2.0 V and 5.0 V (with respect to the ground terminal).

Table 15 ERI signal distribution

Pin	Signal	Description
1	START REQUEST	(L) Request to start injection cycle (for example, by start key on any module). Receiver is the autosampler.
2	STOP	(L) Request to reach system ready state as soon as possible (for example, stop run, abort or finish and stop injection). Receiver is any module performing run-time controlled activities.
3	READY	(H) System is ready for next analysis. Receiver is any sequence controller.
4	POWER ON	(H) All modules connected to system are switched on. Receiver is any module relying on operation of others.
5		Not used
6	SHUT DOWN	(L) System has serious problem (for example, leak: stops pump). Receiver is any module capable to reduce safety risk.
7	START	(L) Request to start run / timetable. Receiver is any module performing run-time controlled activities.
8	PREPARE	(L) Request to prepare for analysis (for example, calibration, detector lamp on). Receiver is any module performing pre-analysis activities.

Special Interfaces

There is no special interface for this module.

ERI (Enhanced Remote Interface)

ERI replaces the AGP Remote Interface that is used in the HP 1090/1040/1050/1100 HPLC systems and Agilent 1100/1200/1200 Infinity HPLC modules. All new InfinityLab LC Series products using the FUSION core electronics use ERI. This interface is already used in the Agilent Universal Interface Box 2 (UIB2)

ERI Description

The ERI interface contains eight individual programmable input/output pins. In addition, it provides 24 V power and 5 V power and a serial data line to detect and recognize further add-ons that could be connected to this interface. This way the interface can support various additional devices like sensors, triggers (in and out) and small controllers, etc.

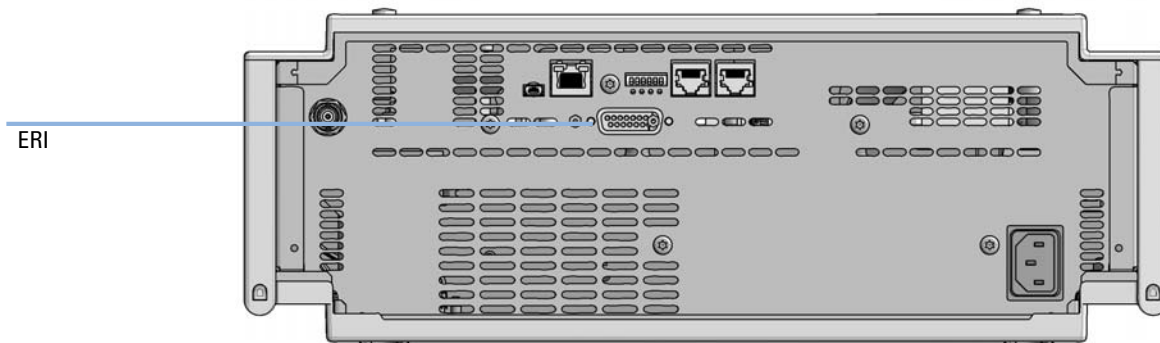

Figure 21 Location of the ERI interface (example shows a G7114A/B VWD)

	Pin	Enhanced Remote
<p>D-Sub female 15way user's view to connector</p> <p>IO 1 IO 2 IO 3 IO 4 IO 5 IO 6 IO 7 IO 8</p> <p>1 2 3 4 5 6 7 8 9 10 11 12 13 14 15</p> <p>1WEprom DGND +5V PGND PGND +24V +24V</p>	1	IO 1 (START REQUEST)
	2	IO 2 (STOP)
	3	IO 3 (READY)
	4	IO 4 (POWER ON)
	5	IO 5 (NOT USED)
	6	IO 6 (SHUT DOWN)
	7	IO 7 (START)
	8	IO 8 (PREPARE)
	9	1 wire DATA
	10	DGND
	11	+5 V ERI out
	12	PGND
	13	PGND
	14	+24 V ERI out
	15	+24 V ERI out

IO (Input/Output) Lines

- Eight generic bi-directional channels (input or output).
- Same as the APG Remote.
- Devices like valves, relays, ADCs, DACs, controllers can be supported/controlled.

1-Wire Data (Future Use)

This serial line can be used to read out an EPROM or write into an EPROM of a connected ERI-device. The firmware can detect the connected type of device automatically and update information in the device (if required).

5V Distribution (Future Use)

- Available directly after turn on of the hosting module (assures that certain base functionality of the device can be detected by firmware).
- For digital circuits or similar.
- Provided 500 mA maximum.
- Short-circuit proof with automatic switch off (by firmware).

24V Distribution (Future Use)

- Available by firmware command (defined turn on/off).
- For devices that need higher power
 - Class 0: 0.5 A maximum (12 W)
 - Class 1: 1.0 A maximum (24 W)
 - Class 2: 2.0 A maximum (48 W)
- Class depends on hosting module's internal power overhead.
- If a connected device requires more power the firmware detects this (overcurrent detection) and provides the information to the user interface.
- Fuse used for safety protection (on board).
- Short circuit will be detected through hardware.

USB (Universal Serial Bus)

USB (Universal Serial Bus) - replaces RS232, supports:

- a PC with control software (for example Agilent Lab Advisor)
- USB Flash Disk

Setting the 6-bit Configuration Switch

The 6-bit configuration switch is located at the rear of the module with FUSION electronics. Switch settings provide configuration parameters for LAN and instrument specific initialization procedures.

All modules with FUSION electronics:

- Default is ALL switches DOWN (best settings).
 - Default IP address for LAN 192.168.254.11
- For specific LAN modes switches 4-5 must be set as required.
- For boot resident/cold start modes switches 1+2 or 6 must be UP.

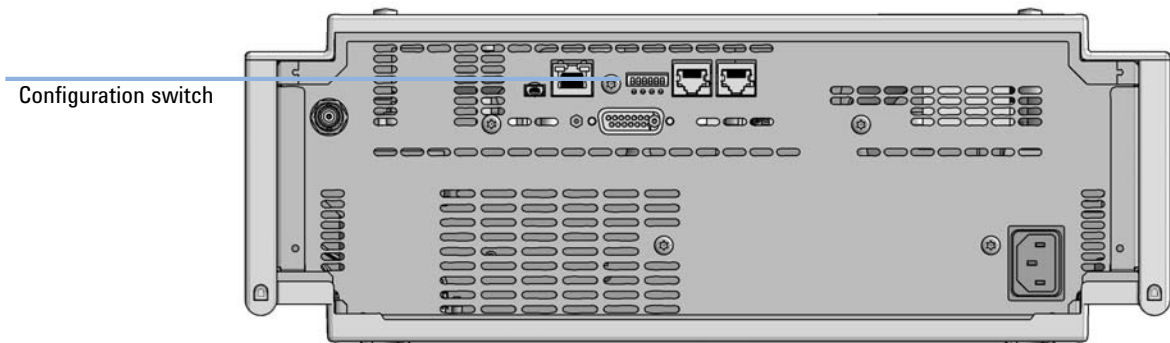

Figure 22 Location of Configuration switch (example shows a G7114A/B VWD)

11 Hardware Information

Setting the 6-bit Configuration Switch

Table 16 6-bit Configuration Switch

	Mode	Function/Setting				
	Switch 1	Switch 2	Switch 3	Switch 4	Switch 5	Switch 6
COM ¹	0	n.a. ²	n.a.	LAN Init Mode		n.a.
Use Default IP Address ³		0	0	0	0	0
Use Stored IP Address		0	0	0	1	0
Use DHCP to request IP Address ⁴		0	0	1	0	0
Test	1	System	n.a.	n.a.	n.a.	ColdStart
Boot Main System / Keep Data		0	0	0	0	0
Boot Resident System / Keep Data		1	0	0	0	0
Boot Main System / Revert to Default Data		0	0	0	0	1
Boot Resident System / Revert to Default Data		1	0	0	0	1

¹ When selecting mode COM, settings are stored to non-volatile memory. When selecting mode TEST, COM settings are taken from non-volatile memory.

² not assigned - Always keep these switches on position '0' (off)

³ Default IP Address is 192.168.254.11

⁴ Host Name will be the MAC address.

Special Settings

Boot-Resident/Main

Firmware update procedures may require this mode in case of firmware loading errors (main/resident firmware part).

If you use the following switch settings and power the instrument up again, the instrument firmware stays in the resident/main mode. In resident mode, it is not operable as a module. It only uses basic functions of the operating system for example, for communication. In this mode the main firmware can be loaded (using update utilities).

Forced Cold Start

A forced cold start can be used to bring the module into a defined mode with default parameter settings.

- Boot Main System / Revert to Default Data

The instrument will boot to main mode and changes to the module's default parameter. May be also required to load resident firmware into the module.

- Boot Resident System / Revert to Default Data

The instrument will boot to resident mode and changes to the module's default parameter. May be also required to load main firmware into the module.

CAUTION

Loss of data

Forced cold start erases all methods and data stored in the non-volatile memory. Exceptions are calibration settings, diagnosis and repair log books which will not be erased.

→ Save your methods and data before executing a forced cold start.

If you use the following switch settings and power the instrument up again, it will start as described above.

11 Hardware Information

Setting the 6-bit Configuration Switch

Table 17 Boot Resident / Forced Coldstart

	SW1	SW2	SW3	SW4	SW5	SW6	Init Mode
	1	0	0	0	0	0	Boot Main System / Keep Data
	1	1	0	0	0	0	Boot Resident System / Keep Data
	1	0	0	0	0	1	Boot Main System / Revert to Default Data
	1	1	0	0	0	1	Boot Resident System / Revert to Default Data

Note: The setting '0' (down) is essential.

Early Maintenance Feedback

Maintenance requires the exchange of components which are subject to wear or stress. Ideally, the frequency at which components are exchanged should be based on the intensity of usage of the module and the analytical conditions, and not on a predefined time interval. The early maintenance feedback (**EMF**) feature monitors the usage of specific components in the instrument, and provides feedback when the user-selectable limits have been exceeded. The visual feedback in the user interface provides an indication that maintenance procedures should be scheduled.

EMF Counters

EMF counters increment with use and can be assigned a maximum limit which provides visual feedback in the user interface when the limit is exceeded. Some counters can be reset to zero after the required maintenance procedure.

Using the EMF Counters

The user-settable **EMF** limits for the **EMF Counters** enable the early maintenance feedback to be adapted to specific user requirements. The useful maintenance cycle is dependent on the requirements for use. Therefore, the definition of the maximum limits need to be determined based on the specific operating conditions of the instrument.

Setting the EMF Limits

The setting of the **EMF** limits must be optimized over one or two maintenance cycles. Initially the default **EMF** limits should be set. When instrument performance indicates maintenance is necessary, take note of the values displayed by the **EMF counters**. Enter these values (or values slightly less than the displayed values) as **EMF** limits, and then reset the **EMF counters** to zero. The next time the **EMF counters** exceed the new **EMF** limits, the **EMF** flag will be displayed, providing a reminder that maintenance needs to be scheduled.

Instrument Layout

The industrial design of the module incorporates several innovative features. It uses Agilent's E-PAC concept for the packaging of electronics and mechanical assemblies. This concept is based upon the use of expanded polypropylene (EPP) layers of foam plastic spacers in which the mechanical and electronic boards components of the module are placed. This pack is then housed in a metal inner cabinet which is enclosed by a plastic external cabinet. The advantages of this packaging technology are:

- virtual elimination of fixing screws, bolts or ties, reducing the number of components and increasing the speed of assembly/disassembly,
- the plastic layers have air channels molded into them so that cooling air can be guided exactly to the required locations,
- the plastic layers help cushion the electronic and mechanical parts from physical shock, and
- the metal inner cabinet shields the internal electronics from electromagnetic interference and also helps to reduce or eliminate radio frequency emissions from the instrument itself.

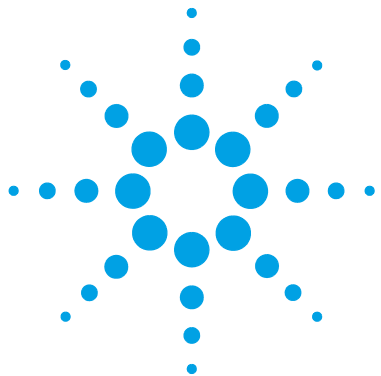

12 LAN Configuration

What You Have to Do First	204
TCP/IP parameter configuration	205
Configuration Switches	206
Initialization Mode Selection	207
Dynamic Host Configuration Protocol (DHCP)	209
General Information (DHCP)	209
Setup (DHCP)	210
Manual Configuration	212
With Telnet	212

This chapter provides information on connecting the module to the Agilent ChemStation PC.



What You Have to Do First

The module has an on-board LAN communication interface.

NOTE

This chapter is generic and may show figures that differ from your module. The functionality is the same.

- 1 Note the MAC (Media Access Control) address for further reference. The MAC or hardware address of the LAN interfaces is a world wide unique identifier. No other network device will have the same hardware address. The MAC address can be found on a label at the rear of the module underneath the configuration switch (see [Figure 24](#) on page 204).

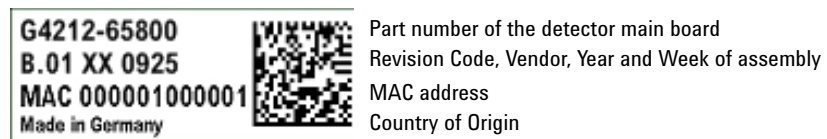

Figure 23 MAC-Label

- 2 Connect the instrument's LAN interface (see [Figure 24](#) on page 204) to
 - the PC network card using a crossover network cable (point-to-point) or
 - a hub or switch using a standard LAN cable.

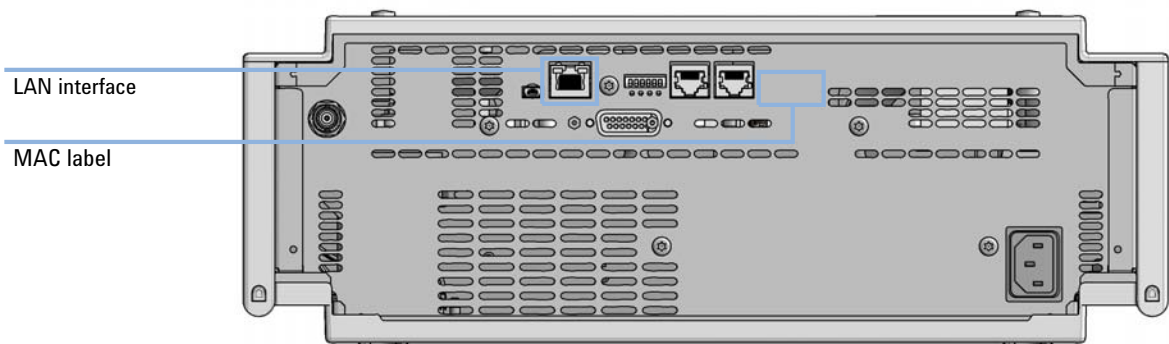

Figure 24 Location of LAN interfaces and MAC label

TCP/IP parameter configuration

To operate properly in a network environment, the LAN interface must be configured with valid TCP/IP network parameters. These parameters are:

- IP address
- Subnet Mask
- Default Gateway

The TCP/IP parameters can be configured by the following methods:

- by automatically requesting the parameters from a network-based DHCP Server (using the so-called Dynamic Host Configuration Protocol). This mode requires a LAN-onboard Module or a G1369C LAN Interface card, see [“Setup \(DHCP\)”](#) on page 210
- by manually setting the parameters using Telnet
- by manually setting the parameters using the Local Controller

The LAN interface differentiates between several initialization modes. The initialization mode (short form ‘init mode’) defines how to determine the active TCP/IP parameters after power-on. The parameters may be derived non-volatile memory or initialized with known default values. The initialization mode is selected by the configuration switch, see [Table 18](#) on page 207.

Configuration Switches

The configuration switch can be accessed at the rear of the module.

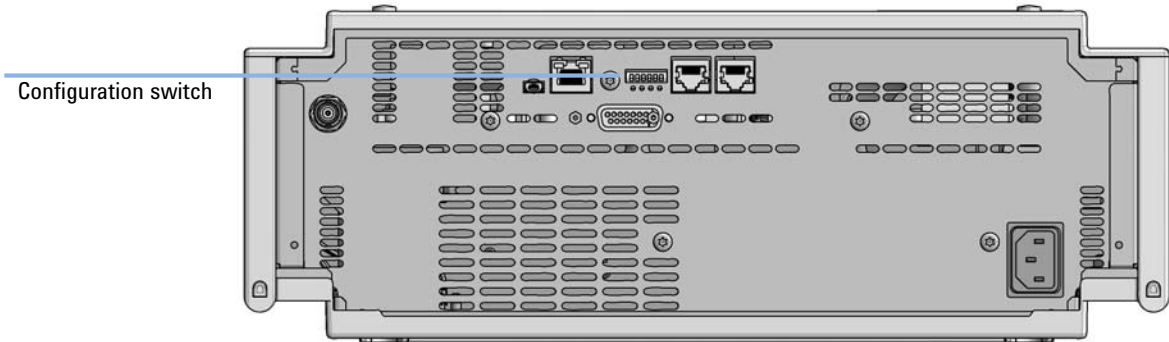

Figure 25 Location of Configuration switch (example shows a G7114A/B VWD)

The module is shipped with all switches set to OFF, as shown above.

NOTE

To perform any LAN configuration, SW1 and SW2 must be set to OFF.

Initialization Mode Selection

The following initialization (init) modes are selectable:

Table 18 Initialization Mode Switches

	SW1	SW2	SW3	SW4	SW5	SW6	Init Mode
	0	0	0	0	0	0	Use Default IP Address
	0	0	0	0	1	0	Use Stored IP Address
	0	0	0	1	0	0	Use DHCP

Note: The setting '0' (down) is essential.

Default IP address for LAN is 192.168.254.11.

DHCP address is the module's LAN MAC address.

Using Stored

When initialization mode **Using Stored** is selected, the parameters are taken from the non-volatile memory of the module. The TCP/IP connection will be established using these parameters. The parameters were configured previously by one of the described methods.

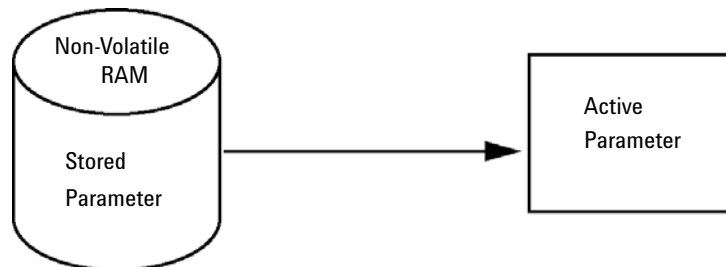

Figure 26 Using Stored (Principle)

Using Default

When **Using Default** is selected, the factory default parameters are taken instead. These parameters enable a TCP/IP connection to the LAN interface without further configuration, see [Table 19](#) on page 208.

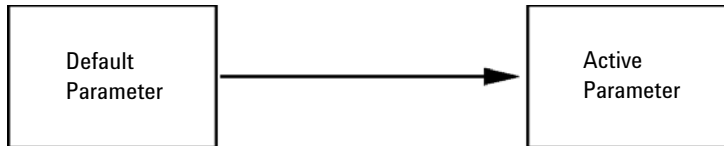

Figure 27 Using Default (Principle)

NOTE

Using the default address in your local area network may result in network problems. Take care and change it to a valid address immediately.

Table 19 Using Default Parameters

IP address:	192.168.254.11
Subnet Mask:	255.255.255.0
Default Gateway	not specified

Since the default IP address is a so-called local address, it will not be routed by any network device. Thus, the PC and the module must reside in the same subnet.

The user may open a Telnet session using the default IP address and change the parameters stored in the non-volatile memory of the module. He may then close the session, select the initialization mode Using Stored, power-on again and establish the TCP/IP connection using the new parameters.

When the module is wired to the PC directly (e.g. using a cross-over cable or a local hub), separated from the local area network, the user may simply keep the default parameters to establish the TCP/IP connection.

NOTE

In the **Using Default** mode, the parameters stored in the memory of the module are not cleared automatically. If not changed by the user, they are still available, when switching back to the mode Using Stored.

Dynamic Host Configuration Protocol (DHCP)

General Information (DHCP)

The Dynamic Host Configuration Protocol (DHCP) is an auto configuration protocol used on IP networks. The DHCP functionality is available on all Agilent HPLC modules with on-board LAN Interface or LAN Interface Card G1369C, and “B”-firmware (B.06.40 or above) or modules with "D"-firmware. All modules should use latest firmware from the same set.

When the initialization mode “DHCP” is selected, the card tries to download the parameters from a DHCP Server. The parameters obtained become the active parameters immediately. They are not stored to the non-volatile memory of the card.

Besides requesting the network parameters, the card also submits its hostname to the DHCP Server. The hostname equals the MAC address of the card, e.g. *0030d3177321*. It is the DHCP server's responsibility to forward the hostname/address information to the Domain Name Server. The card does not offer any services for hostname resolution (e.g. NetBIOS).

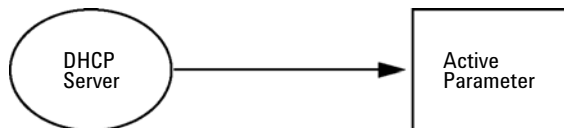

Figure 28 DHCP (Principle)

NOTE

- 1 It may take some time until the DHCP server has updated the DNS server with the hostname information.
- 2 It may be necessary to fully qualify the hostname with the DNS suffix, e.g. *0030d3177321.country.company.com*.
- 3 The DHCP server may reject the hostname proposed by the card and assign a name following local naming conventions.

12 LAN Configuration

Dynamic Host Configuration Protocol (DHCP)

Setup (DHCP)

The DHCP functionality is available on all Agilent HPLC modules with on-board LAN Interface or LAN Interface Card G1369C, and "B"-firmware (B.06.40 or above) or modules with "D"-firmware. All modules should use latest firmware from the same set.

- 1 Note the MAC address of the LAN interface (provided with G1369C LAN Interface Card or Main Board). This MAC address is on a label on the card or at the rear of the main board, e.g. *0030d3177321*.

On the Local Controller the MAC address can be found under **Details** in the LAN section.

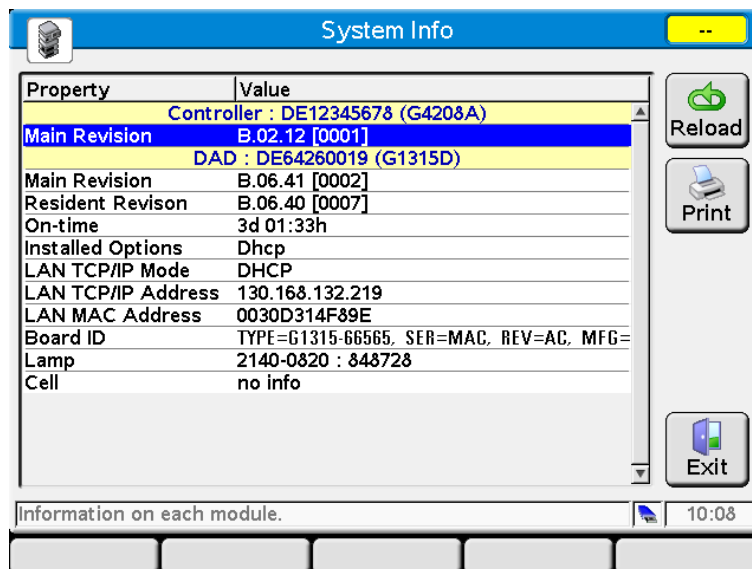

The screenshot shows the 'System Info' window with a table of properties and values. The 'Main Revision' row is highlighted in blue. To the right of the table are buttons for 'Reload', 'Print', and 'Exit'. At the bottom, there is a status bar with 'Information on each module.' and a clock showing '10:08'.

Property	Value
Controller : DE12345678 (G4208A)	
Main Revision	B.02.12 [0001]
DAD : DE64260019 (G1315D)	
Main Revision	B.06.41 [0002]
Resident Revision	B.06.40 [0007]
On-time	3d 01:33h
Installed Options	Dhcp
LAN TCP/IP Mode	DHCP
LAN TCP/IP Address	130.168.132.219
LAN MAC Address	0030D314F89E
Board ID	TYPE=G1315-66565, SER=MAC, REV=AC, MFG=
Lamp	2140-0820 : 848728
Cell	no info

Figure 29 LAN Setting on Instant Pilot

- 2 Set the Configuration Switch to DHCP either on the G1369C LAN Interface Card or the main board of above mentioned modules.

Table 20 G1369C LAN Interface Card (configuration switch on the card)

SW 4	SW 5	SW 6	SW 7	SW 8	Initialization Mode
ON	OFF	OFF	OFF	OFF	DHCP

Table 21 LC Modules with 8-bit configuration switch (B-firmware) (configuration switch at rear of the instrument)

SW 6	SW 7	SW 8	Initialization Mode
ON	OFF	OFF	DHCP

- 3 Turn on the module that hosts the LAN interface.
- 4 Configure your Control Software (e.g. OpenLAB CDS ChemStation Edition, Lab Advisor, Firmware Update Tool) and use MAC address as host name, e.g. *0030d3177321*.

The LC system should become visible in the control software (see Note in section “[General Information \(DHCP\)](#)” on page 209).

Manual Configuration

Manual configuration only alters the set of parameters stored in the non-volatile memory of the module. It never affects the currently active parameters. Therefore, manual configuration can be done at any time. A power cycle is mandatory to make the stored parameters become the active parameters, given that the initialization mode selection switches are allowing it.

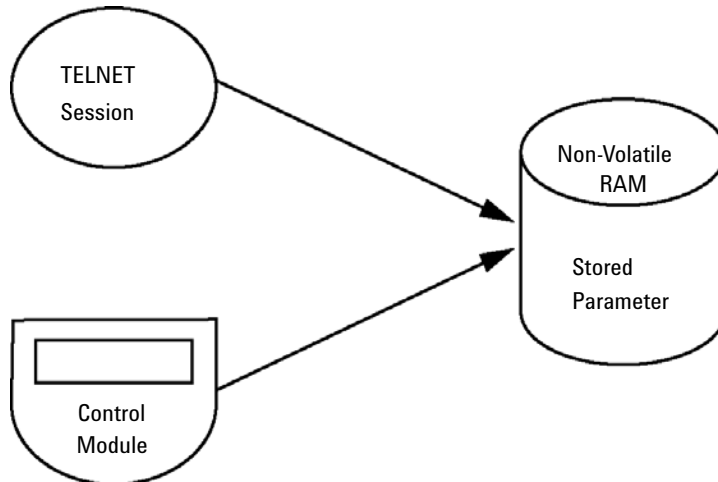

Figure 30 Manual Configuration (Principle)

With Telnet

Whenever a TCP/IP connection to the module is possible (TCP/IP parameters set by any method), the parameters may be altered by opening a Telnet session.

- 1 Open the system (DOS) prompt window by clicking on Windows **START** button and select "**Run...**". Type "cmd" and press OK.

2 Type the following at the system (DOS) prompt:

- c:\>telnet <IP address> or
- c:\>telnet <host name>

```

C:\WINDOWS\system32\cmd.exe
C:\>telnet 134.40.30.205
  
```

Figure 31 Telnet - Starting a session

where <IP address> may be the assigned address from a Bootp cycle, a configuration session with the Handheld Controller, or the default IP address (see “[Configuration Switches](#)” on page 206).

When the connection was established successfully, the module responds with the following:

```

Telnet 134.40.30.205
Agilent Technologies G4212A PR00100015
>=
  
```

Figure 32 A connection to the module is made

- 3 Type `?` and press enter to see the available commands.

```
cx Telnet 134.40.30.205
Agilent Technologies G4212A PR00100015
>?
command syntax      description
-----
?                    display help info
/                    display current LAN settings
ip <x.x.x.x>         set IP Address
sm <x.x.x.x>         set Subnet Mask
gw <x.x.x.x>         set Default Gateway
exit                exit shell
>
```

Figure 33 Telnet Commands

Table 22 Telnet Commands

Value	Description
<code>?</code>	displays syntax and descriptions of commands
<code>/</code>	displays current LAN settings
<code>ip <x.x.x.x></code>	sets new ip address
<code>sm <x.x.x.x></code>	sets new subnet mask
<code>gw <x.x.x.x></code>	sets new default gateway
<code>exit</code>	exits shell and saves all changes

- 4 To change a parameter follows the style:

- parameter value, for example:
`ip 134.40.28.56`

Then press [Enter], where parameter refers to the configuration parameter you are defining, and value refers to the definitions you are assigning to that parameter. Each parameter entry is followed by a carriage return.

- 5 Use the “/” and press Enter to list the current settings.

```

Telnet 134.40.30.205
>/
LAN Status Page
-----
MAC Address   : 0030D317521C
Init Mode    : Using Stored
-----
TCP/IP Properties
- active -
IP Address   : 134.40.30.205
Subnet Mask  : 255.255.240.0
Def. Gateway : 134.40.24.1
-----
TCP/IP Status : Ready
Controllers  : no connections
>_

```

Figure 34 Telnet - Current settings in "Using Stored" mode

information about the LAN interface
MAC address, initialization mode
Initialization mode is Using Stored
active TCP/IP settings

TCP/IP status - here ready
connected to PC with controller software (e.g. Agilent
ChemStation), here not connected

- 6 Change the IP address (in this example 192.168.254.12) and type “/” to list current settings.

```

Telnet 134.40.30.205
>ip 192.168.254.12
>/
LAN Status Page
-----
MAC Address   : 0030D317521C
Init Mode    : Using Stored
-----
TCP/IP Properties
- active -
IP Address   : 134.40.30.205
Subnet Mask  : 255.255.240.0
Def. Gateway : 134.40.24.1
- stored -
IP Address   : 192.168.254.12
Subnet Mask  : 255.255.240.0
Def. Gateway : 134.40.24.1
-----
TCP/IP Status : Ready
Controllers  : no connections
>_

```

Figure 35 Telnet - Change IP settings

change of IP setting to
Initialization mode is Using Stored
active TCP/IP settings

stored TCP/IP settings in non-volatile memory

connected to PC with controller software (e.g. Agilent
ChemStation), here not connected

12 LAN Configuration

Manual Configuration

- 7 When you have finished typing the configuration parameters, type **exit** and press **Enter** to exit with storing parameters.

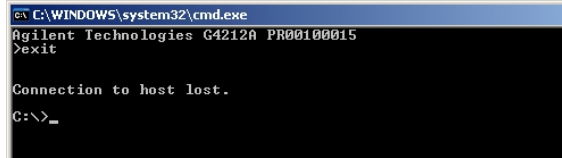

```
ca C:\WINDOWS\system32\cmd.exe
Agilent Technologies G4212A PR00100015
>exit

Connection to host lost.
C:\>_
```

Figure 36 Closing the Telnet Session

NOTE

If the Initialization Mode Switch is changed now to “Using Stored” mode, the instrument will take the stored settings when the module is re-booted. In the example above it would be 192.168.254.12.

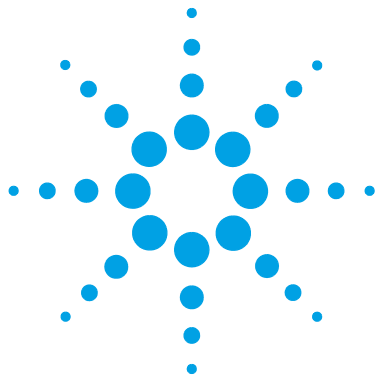

13 Appendix

General Safety Information	218
General Safety Information	218
Safety Standards	218
General	218
Before Applying Power	219
Ground the Instrument	219
Do Not Operate in an Explosive Atmosphere	220
Do Not Remove the Instrument Cover	220
Do Not Modify the Instrument	220
In Case of Damage	220
Solvents	221
Safety Symbols	222
Waste Electrical and Electronic Equipment (WEE) Directive	224
Radio Interference	225
Sound Emission	226
Agilent Technologies on the Internet	227

This chapter provides addition information on safety, legal and web.



General Safety Information

General Safety Information

The following general safety precautions must be observed during all phases of operation, service, and repair of this instrument. Failure to comply with these precautions or with specific warnings elsewhere in this manual violates safety standards of design, manufacture, and intended use of the instrument. Agilent Technologies assumes no liability for the customer's failure to comply with these requirements.

WARNING

Ensure the proper usage of the equipment.

The protection provided by the equipment may be impaired.

→ The operator of this instrument is advised to use the equipment in a manner as specified in this manual.

Safety Standards

This is a Safety Class I instrument (provided with terminal for protective earthing) and has been manufactured and tested according to international safety standards.

General

Do not use this product in any manner not specified by the manufacturer. The protective features of this product may be impaired if it is used in a manner not specified in the operation instructions.

Before Applying Power

WARNING

Wrong voltage range, frequency or cabling

Personal injury or damage to the instrument

- Verify that the voltage range and frequency of your power distribution matches to the power specification of the individual instrument.
 - Never use cables other than the ones supplied by Agilent Technologies to ensure proper functionality and compliance with safety or EMC regulations.
 - Make all connections to the unit before applying power.
-

NOTE

Note the instrument's external markings described under “[Safety Symbols](#)” on page 222.

Ground the Instrument

WARNING

Missing electrical ground

Electrical shock

- If your product is provided with a grounding type power plug, the instrument chassis and cover must be connected to an electrical ground to minimize shock hazard.
 - The ground pin must be firmly connected to an electrical ground (safety ground) terminal at the power outlet. Any interruption of the protective (grounding) conductor or disconnection of the protective earth terminal will cause a potential shock hazard that could result in personal injury.
-

Do Not Operate in an Explosive Atmosphere

WARNING

Presence of flammable gases or fumes

Explosion hazard

→ Do not operate the instrument in the presence of flammable gases or fumes.

Do Not Remove the Instrument Cover

WARNING

Instrument covers removed

Electrical shock

→ Do Not Remove the Instrument Cover

→ Only Agilent authorized personnel are allowed to remove instrument covers. Always disconnect the power cables and any external circuits before removing the instrument cover.

Do Not Modify the Instrument

Do not install substitute parts or perform any unauthorized modification to the product. Return the product to an Agilent Sales and Service Office for service and repair to ensure that safety features are maintained.

In Case of Damage

WARNING

Damage to the module

Personal injury (for example electrical shock, intoxication)

→ Instruments that appear damaged or defective should be made inoperative and secured against unintended operation until they can be repaired by qualified service personnel.

Solvents

WARNING

Toxic, flammable and hazardous solvents, samples and reagents

The handling of solvents, samples and reagents can hold health and safety risks.

- When working with these substances observe appropriate safety procedures (for example by wearing goggles, safety gloves and protective clothing) as described in the material handling and safety data sheet supplied by the vendor, and follow good laboratory practice.
- Do not use solvents with an auto-ignition temperature below 200 °C (392 °F). Do not use solvents with a boiling point below 56 °C (133 °F).
- Avoid high vapor concentrations. Always keep the temperature in the sample compartment at least 25 K below the boiling point of the solvent used.
- Do not operate the instrument in an explosive atmosphere.
- Do not use solvents of ignition Class IIC according IEC 60079-20-1 (for example, carbon disulfide).
- Reduce the volume of substances to the minimum required for the analysis.
- Never exceed the maximum permissible volume of solvents (8 L) in the solvent cabinet. Do not use bottles that exceed the maximum permissible volume as specified in the usage guideline for solvent cabinet.
- Ground the waste container.
- Regularly check the filling level of the waste container. The residual free volume in the waste container must be large enough to collect the waste liquid.
- To achieve maximal safety, regularly check the tubing for correct installation.

NOTE

For details, see the usage guideline for the solvent cabinet. A printed copy of the guideline has been shipped with the solvent cabinet, electronic copies are available in the Agilent Information Center or via the Internet.

Safety Symbols

Table 23 Symbols













	The apparatus is marked with this symbol when the user should refer to the instruction manual in order to protect risk of harm to the operator and to protect the apparatus against damage.
	Indicates dangerous voltages.
	Indicates a protected ground terminal.
	The apparatus is marked with this symbol when hot surfaces are available and the user should not touch it when heated up.
	Sample Cooler unit is designed as vapor-compression refrigeration system. Contains fluorinated greenhouse gas (refrigerant) according to the Kyoto protocol. For specifications of refrigerant, charge capacity, carbon dioxide equivalent (CDE), and global warming potential (GWP) see instrument label.
	Flammable Material For Sample Thermostat which uses flammable refrigerant consult Agilent Information Center / User Manual before attempting to install or service this equipment. All safety precautions must be followed.
	Confirms that a manufactured product complies with all applicable European Community directives. The European Declaration of Conformity is available at: http://regulations.corporate.agilent.com/DoC/search.htm
	Manufacturing date.
	Power symbol indicates On/Off. The apparatus is not completely disconnected from the mains supply when the power switch is in the Off position

Table 23 Symbols

	<p>Pacemaker Magnets could affect the functioning of pacemakers and implanted heart defibrillators. A pacemaker could switch into test mode and cause illness. A heart defibrillator may stop working. If you wear these devices keep at least 55 mm distance to magnets. Warn others who wear these devices from getting too close to magnets.</p>
	<p>Magnetic field Magnets produce a far-reaching, strong magnetic field. They could damage TVs and laptops, computer hard drives, credit and ATM cards, data storage media, mechanical watches, hearing aids and speakers. Keep magnets at least 25 mm away from devices and objects that could be damaged by strong magnetic fields.</p>
	<p>Indicates a pinching or crushing hazard</p>
	<p>Indicates a piercing or cutting hazard.</p>

WARNING

A WARNING

alerts you to situations that could cause physical injury or death.

- Do not proceed beyond a warning until you have fully understood and met the indicated conditions.

CAUTION

A CAUTION

alerts you to situations that could cause loss of data, or damage of equipment.

- Do not proceed beyond a caution until you have fully understood and met the indicated conditions.

13 Appendix

Waste Electrical and Electronic Equipment (WEE) Directive

Waste Electrical and Electronic Equipment (WEE) Directive

This product complies with the European WEEE Directive marking requirements. The affixed label indicates that you must not discard this electrical/electronic product in domestic household waste.



NOTE

Do not dispose of in domestic household waste

To return unwanted products, contact your local Agilent office, or see <http://www.agilent.com> for more information.

Radio Interference

Cables supplied by Agilent Technologies are screened to provide optimized protection against radio interference. All cables are in compliance with safety or EMC regulations.

Test and Measurement

If test and measurement equipment is operated with unscreened cables, or used for measurements on open set-ups, the user has to assure that under operating conditions the radio interference limits are still met within the premises.

Sound Emission

Manufacturer's Declaration

This statement is provided to comply with the requirements of the German Sound Emission Directive of 18 January 1991.

This product has a sound pressure emission (at the operator position) < 70 dB.

- Sound Pressure $L_p < 70$ dB (A)
- At Operator Position
- Normal Operation
- According to ISO 7779:1988/EN 27779/1991 (Type Test)

Agilent Technologies on the Internet

For the latest information on products and services visit our worldwide web site on the Internet at:

<http://www.agilent.com>

Index

A

absorber capillary 16
 accessory kit 170
 active inlet valve body 117
 active inlet valve
 exchanging 137
 active seal wash 10, 61
 Agilent Lab Advisor software 73
 Agilent Lab Advisor 73, 98
 Agilent
 on internet 227
 AIV fuse 87
 algae growth 55
 algae 41
 ambient non-operating temperature 29
 ambient operating temperature 29
 analog signal 191
 AUTO mode 19

B

ball-screw drive 15
 bench space 28
 blockage 88
 bottle head assembly 168
 buffer application 41
 buffer solutions 10

C

cable
 CAN 180
 LAN 180
 overview 172
 RS-232 181

cables
 analog 174
 remote 176
 calibration
 solvent compressibility 66
 CAN
 cable 180
 capillary
 absorber 16
 cleaning 115
 compensation sensor open 82
 compensation sensor short 82
 compensation, compressibility 30
 composition accuracy 31
 composition precision 31
 composition range 31
 composition ripple 103
 compressibility calibration 103
 compressibility compensation 30, 66
 condensation 28
 configuration switch 206
 cover parts 169

D

damper
 when to remove 63
 degasser limit not reached 94
 degasser signal fail 93
 delay volume 30, 63
 design 11
 DHCP
 general information 209
 setup 210
 dimensions 29

doors
 install 118
 remove 118
 dual-piston in-series design 11

E

electrical connections
 descriptions of 187
 electronic fuse of SSV open 87
 electronic waste 224
 electrostatic discharge (ESD) 114
 EMF
 early maintenance feedback 201
 encoder missing 89
 error messages, degasser limit not reached 94
 error messages, degasser signal fail 93
 error messages
 AIV fuse 87
 compensation sensor open 82
 compensation sensor short 82
 electronic fuse of SSV open 87
 encoder missing 89
 fan failed 83
 index adjustment 92
 index limit 91
 index missing 92
 initialization failed 93
 leak sensor open 81
 leak sensor short 81
 leak 80
 lost CAN partner 79
 motor-drive power 88
 overpressure 102, 106, 104, 98
 pressure above upper limit 84

- pressure below lower limit 85
- pressure signal missing 85
- pump head missing 91
- remote timeout 79
- servo restart failed 90
- shutdown 78
- timeout 78
- valve failed 86
- error
 - solvent zero counter 84
- exchanging
 - active inlet valve 117, 137
 - outlet valve sieve 117, 144
 - outlet valve 117, 144
 - pistons 117, 117
 - pump seals 117
 - purge valve frit 117, 120
 - purge valve 117, 120
 - seal wash cartridge 140
 - solvent selection valve 117, 148
 - wash seals 117
- F**
- fan failed 83
- filter
 - solvent inlet 41
- firmware
 - description 184
 - main system 184
 - resident system 184
 - update tool 185
 - updates 185, 151
 - upgrade/downgrade 151
- flow accuracy 30
- flow precision 30
- flow range 10, 30
- flow rate
 - minimum 41
- frequency range 29
- pressure below lower limit 85
- pressure signal missing 85
- pump head missing 91
- remote timeout 79
- servo restart failed 90
- shutdown 78
- timeout 78
- valve failed 86
- error
 - solvent zero counter 84
- exchanging
 - active inlet valve 117, 137
 - outlet valve sieve 117, 144
 - outlet valve 117, 144
 - pistons 117, 117
 - pump seals 117
 - purge valve frit 117, 120
 - purge valve 117, 120
 - seal wash cartridge 140
 - solvent selection valve 117, 148
 - wash seals 117
- G**
- gradient formation 30
- H**
- high-pressure mixing 10
- humidity 29
- hydraulic path without solvent selection valve 156
- hydraulic system 30
- I**
- index adjustment 92
- index limit 91
- index missing 92
- initialization failed 93
- initialization 16
- installation
 - bench space 28
- installing
 - pump head assembly 134
- install
 - doors 118
- instrument layout 202
- interfaces
 - Infinity II 189
- internet 227
- introduction to the pump 10
- L**
- LAN
 - cable 180
 - configuration switche 206
 - manual configuration with telnet 212
 - manual configuration 212
 - TCP/IP parameter configuration 205
 - using default 208
 - using stored 207
- what you have to do first 204, 204
- leak parts 142
- leak rate test
 - evaluating results 108
 - potential causes of failure 109
 - running the test 107
- leak sensor open 81
- leak sensor short 81
- leak sensor
 - incompatibility 23
- leak 80
- line frequency 29
- line voltage 29
- lost CAN partner 79
- M**
- MAC
 - address 204
- main assemblies, overview 116
- maintenance procedures 117
- maintenance
 - feedback 201
 - introduction 112
 - pump head with seal wash 117, 130
 - pump head without seal wash 117, 127
 - replacing firmware 151
- manual configuration
 - of LAN 212
- message
 - remote timeout 79
- minimum flow rate 41
- mixer 11
 - when to remove 63
- module firmware
 - replace 151
- motor-drive power 88

Index

N

non-operating altitude 29
non-operating temperature 29
normal phase 57
 seals 58

O

operating Altitude 29
operating temperature 29
outlet valve 117, 144
overpressure error 98, 102, 104, 106
overview
 cable 172

P

parts identification
 cables 171
parts
 accessory kit 170
 active inlet valve 164
 bottle head assembly 168
 cover 169
 hydraulic path without solvent
 selection valve 156
 solvent cabinet 167
pH range 30
physical specifications 29
piston 15
power consideration 26
power consumption 29
power cords 27
pressure above upper limit 84
pressure below lower limit 85
pressure pulsation 19, 67
pressure ripple 103
pressure signal missing 85
pressure test 70
 results 102

pressure
 operating range 30
 pulsation 30
PTFE frit 117
pulsation
 pressure 19
pump elasticity calibration 71, 106
pump head assembly 117
 installing 134
pump head missing 91
pump head with seal wash 130
pump head without seal wash
 maintenance 127
pump head 117, 117
 remove 125
 seal wash 130
pump seals 41
purge valve frit
 exchange 120
purge valve
 exchange 120
 o-ring 123

R

radio interference 225
recommended pH range 30
remote (ERI) 192
remote
 cables 176
remove damper and mixer 63
remove
 doors 118
 pump head 125
removing
 pump head assembly 117
repairs
 replacing firmware 151
replace
 leak parts 142

replacing
 o-ring of purge valve 123
results
 pressure test 102, 98
ripple
 composition 103
 pressure 103
RS-232C
 cable 181

S

safety class I 218
safety
 general information 218
 standards 29
 symbols 222
sapphire piston 15
seal wash cartridge
 exchanging 140
seal wash
 wash solvent 61
 when to use 61
seals 41
serial number
 information 188
servo restart failed 90
shutdown 78
sieve 117, 144
simple repair procedures 117
site requirements 25
 power cords 27
solvent cabinet 41, 167
solvent calibration 103
solvent compressibility calibration 66,
71, 104
solvent filters
 checking 55
 cleaning 56
 prevent blocking 55

solvent inlet filter 41
 solvent selection valve
 exchanging 148
 solvent zero counter 84
 sound emission 226
 special interfaces 193
 special settings
 boot main 199
 boot-resident 199
 specification
 physical 29
 specifications
 communications 31
 stroke volume 15, 19

T

TCP/IP parameter configuration 205
 telnet
 configuration 212
 temperature sensor 80
 test functions 70
 tests
 pressure test results 98
 pump elasticity calibration 106
 solvent calibration 103
 solvent compressibility
 calibration 104
 timeout 78
 troubleshooting
 error messages 70, 77
 status indicators 70

U

USB 191

V

vacuum degasser 10
 operational hints 60
 when to use 60

valve failed 86
 valve
 active inlet valve, replacement 117
 variable reluctance motor 15
 variable stroke volume 19
 voltage range 29

W

wash solvent 61
 waste
 electrical and electronic
 equipment 224
 WEEE directive 224
 weight 29

In This Book

This manual contains technical reference information about the Agilent 1260 Infinity II Binary Pump G7112B. The manual describes the following:

- introduction,
- site requirements and specifications,
- using the binary pump,
- optimizing performance,
- troubleshooting and diagnostics,
- maintenance,
- parts and materials for maintenance,
- identifying cables,
- hardware information,
- appendix.

© Agilent Technologies 2016-2018

Printed in Germany
08/2018



G7112-90000
Rev. B